

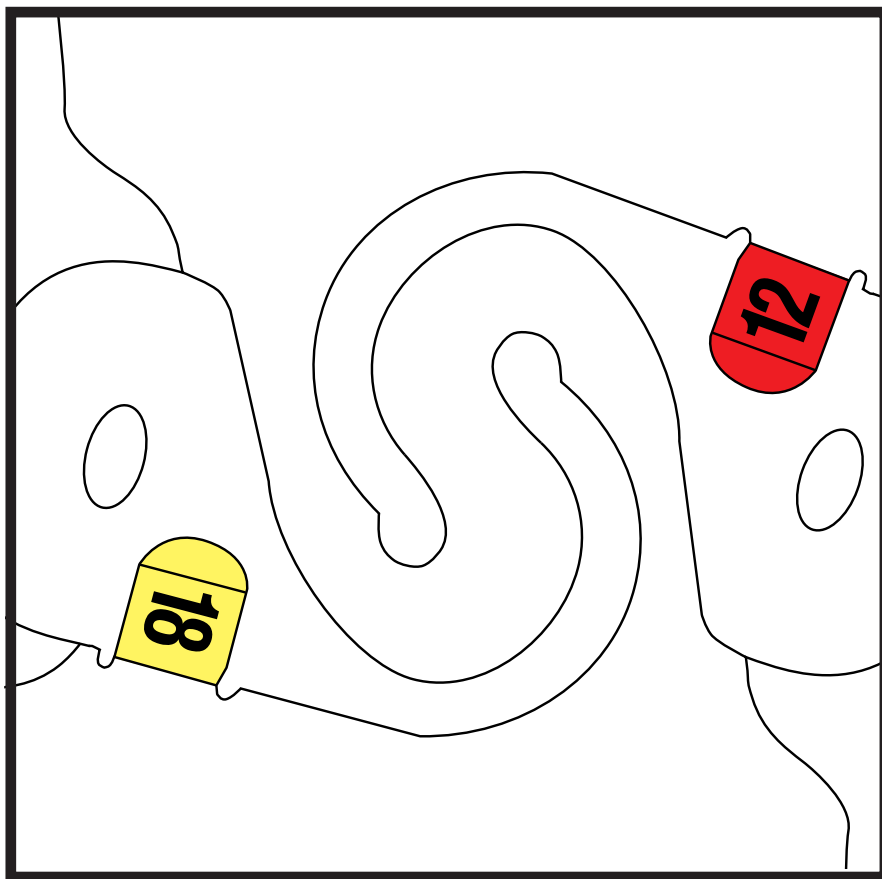

# Apparel Suppliers Manual



**Approved Hanger Range**



# 1. INTRODUCTION

---

The Target hanger range consists of garment, lingerie, fashion accessories and footwear hangers. All these hangers can take the form of merchandise delivered hanging, in bags, or included with merchandise flat packed in cartons.

This manual has been compiled for Suppliers, Quality Assurance, and Buying Office Personnel.

The Buying Office is responsible to select the most appropriate hanger to suit merchandise for floor ready presentation.

## **IMPORTANT NOTICE:**

To ensure integrity and consistency for Target from the 28<sup>th</sup> June 2004, all hangers and accessories **MUST** be purchased from TIC, the only approved Service Provider for Target hangers and accessories. Please note this is a requirement for conducting business with Target.

Failure by suppliers to comply with this condition post 28<sup>th</sup> June 2004 will represent a substantial breach of Target conditions of supply, and penalties may apply, if infringements occur. Target will monitor compliance through monthly reporting procedures and store audits, to ensure the objectives are met.

The hangers and accessories are the registered intellectual property of TIC, and as such, suppliers are not permitted to copy or reproduce these by any means.

## 2. ORDERING

---

Target request that suppliers place orders by accessing the TIC website and following the prompts. To use the on-line ordering system, suppliers must be registered with TIC, and be issued with a password. All orders placed on-line will be automatically confirmed by return email. **All orders will be rounded up to the nearest full carton.**

It is the Suppliers and/or Agents responsibility to ensure that the hanger specified by Target is the only hanger used on Target garments and that the colour coded size labelling system is used correctly.

Minimum ordering - There must be a minimum of 3 cartons ordered for each order placed.

### 2.1 Australia, New Zealand, Fiji, and Pacific Basin.

Orders can only be placed on-line by logging on to [www.ticgroup.com.au](http://www.ticgroup.com.au) click onto Retail Accessories and follow the prompts. All orders placed on-line will be automatically confirmed by return email.

Lead Times – all orders will be processed and dispatched within 2 business days.

Upon receipt of this package it is advised that Australian manufacturers and Australian based importers need to apply to TIC for a credit application form.

### 2.2 China, other Asian and European Countries

Orders should be placed on-line by logging on to [www.ticgroupasia.com](http://www.ticgroupasia.com) click onto Retail Accessories and follow the prompts. All orders placed on-line will be automatically confirmed by return email.

Lead Times: On receipt of all **approved Customs documentation** from the customs office, orders will be processed for dispatch **within 3 working days.**

**Important Note for China only: Chinese Customs Documentation supporting the export of these hangers must be supplied to TIC before orders can be processed.**

## 3. CUSTOMS

---

### 3.1 Australia and New Zealand Customs Requirements:

Importers should ensure that the hanger cost is shown separately on Import Invoices and as a separate entry on the Import Duty Warrant under tariff item 3924-90-00 at 5% duty. All apparel merchandise invoices must include a declaration as per the following example:

**Example:**

“The unit cost of hangers, of Chinese origin, included on order 1234567 is US\$0.15 each and this cost is included on the invoice cost per unit of the product.”

Overseas suppliers and Australian importers should ensure that the hanger cost (per unit) and hanger origin is shown on the invoice.

If you have any queries, please contact the TIC (Retail Accessories) office. We suggest that you also consult with your Customs Agent.

### 3.2 China

Upon receipt of orders at TIC, a fax, accompanied by a telephone call is made to the Suppliers, requesting a copy of their Customs Documentation.

From receipt of all Customs documentation goods are despatched within 3 business days.

### 3.3 Other Countries

For hangers imported into other countries it is the responsibility of the Importer to ensure correct customs procedures are followed. Freight, all associated shipping costs, duties etc. are the responsibility of suppliers when receiving good in “Other Countries.”

## 4. PAYMENT TERMS

---

### 4.1 Australian and New Zealand Suppliers/Importers

- Suppliers who do not have a credit facility with TIC will be required to pay for goods prior to delivery. IE. Payment Pre Delivery (PPD).
- For a Trading Account / Credit. Suppliers must complete the Supplier Registration Form and submit to TIC (Refer to Appendix A). If credit is approved by TIC, terms of payment are 30 days from invoice.
- Subject to approval by TIC, where an Australian based importer requires delivery to their overseas manufacturer, the Australian based importer may receive trading terms of 30 days from invoice.

### 4.2 Target – Overseas Manufacturers

- Approved Target direct overseas suppliers may receive credit terms of 30 days from invoice, subject to a credit approval by TIC.

### 4.3 Other Overseas Agents and Manufacturers

- Overseas Agents and Manufacturers who supply Target Importers will receive goods on a PPD (payment pre delivery) basis, unless a previous Application for Credit has been approved.

Note: If invoices are not paid within 30 days from the date of invoice, no further deliveries will be made.

When making payment – a remittance advice with full payment details is required.

**Suppliers please note that TIC banking details are clearly displayed on all TIC invoices.**

## 5. TIC GROUP CONTACT INFORMATION

---

### **TIC Group – Melbourne Office (Head Office)**

214 Blackshaws Road  
Altona North VIC Australia 3025  
Telephone: (03) 9393 3737  
Toll Free: 1800 790 110  
Facsimile Number: (03) 9393 3778  
Email: [hangers@ticgroup.com.au](mailto:hangers@ticgroup.com.au)  
Web: [www.ticgroup.com.au](http://www.ticgroup.com.au)

### **TIC Group – Sydney (Sales Office)**

Unit 3, 79 Williamson Road  
Ingleburn NSW Australia 2565  
Telephone Number: (02) 9618 5133  
Facsimile Number: (02) 9618 5733  
Email: [hangers.syd@ticgroup.com.au](mailto:hangers.syd@ticgroup.com.au)  
Web: [www.ticgroup.com.au](http://www.ticgroup.com.au)

All deliveries are ex TIC Melbourne National Warehouse.  
All invoices will be issued in AUD\$ currency.

### **TIC Group – Hong Kong Office**

Unit 3, 5, 6 and 7, 29/F Saxon Tower,  
7 Cheung Shun Street,  
Lai Chi Kok, KOWLOON,  
HONG KONG  
Telephone: (852) 2148 3685  
Facsimile Number: (852) 2148 3085  
Email: [hangers.hk@ticgroupasia.com](mailto:hangers.hk@ticgroupasia.com)  
Web: [www.ticgroupasia.com](http://www.ticgroupasia.com)

### **TIC Group–Ningbo Office (Represented by Ningbo Xunxing Trade Co Ltd)**

No 15 Chuang Ye Da Dao  
West District of Free Trade Zone,  
Ningbo, China  
Telephone: 86 574 2687 3733  
Facsimile Number: 86 574 8682 3880  
Email: [hangers.cn@ticgroupasia.com](mailto:hangers.cn@ticgroupasia.com)  
Web: [www.ticgroupasia.com](http://www.ticgroupasia.com)

### **TIC Group–Shanghai Office**

Unit E, 17/Floor, Hengji Plaza  
No 99 East Huaihai Road  
Huangpu District  
200021, Shanghai,China  
Telephone: 86 21 6386 0808 extn 316  
Facsimile Number: 86 21 6386 9511 / 6386 9533  
Email: [hangers.cn@ticgroupasia.com](mailto:hangers.cn@ticgroupasia.com)  
Web: [www.ticgroupasia.com](http://www.ticgroupasia.com)

All invoices will be issued in US\$ currency.



# TIC (Retail Accessories) Pty Ltd.

232 Blackshaws Road, Victoria, Australia 3025

Phone: 613 9393 3737

Fax: 613 9392 2332

Email: [hangers@ticgroup.com.au](mailto:hangers@ticgroup.com.au)

ABN: 31 007 422 291

## REGISTRATION FOR AUSTRALIAN, NEW ZEALAND BASED AND PACIFIC RIM MANUFACTURERS AND IMPORTERS

If granted a trading account(s) the Applicant agrees to conduct this/these account(s) within TIC (Retail Accessories) Pty Ltd. trading terms as they apply from time to time.

**TRADING DETAILS:**

**ABN:** .....

Trading Name:.....

Trading Address:.....

.....Postcode/Zip Code:.....

Phone:.....Fax:.....

Email: .....

**IF SOLE TRADER/PARTNERSHIP** (Complete this Section)

Owner's Name:.....

Private Address:.....

Phone:.....Date of Birth:.....Drivers Licence Number:.....

Owner's Name:.....

Private Address:.....

Phone:.....Date of Birth:.....Drivers Licence Number:.....

**IF A COMPANY** (Complete this Section)

**Company**

**Name:**.....

**Registered**

**Address:**.....

.....**Phone:**.....

**Business License Number:**.....

**DETAILS OF DIRECTORS:**

**Name:**.....

**Private**

**Address:**.....

**Phone:**.....

**Name:**.....

**Private**

**Address:**.....

**Phone:**.....

**Name:**.....

**Private**

**Address:**.....

**Phone:**.....

**BANK DETAILS:**

**Bank:**.....**Branch:**.....

**Account Name:**.....

**Account Number:**.....

**Monthly Credit Applied For:**.....

**Anticipated Annual Spend A\$:**.....

**BUSINESS REFERENCES:**

**Name:**.....

**Address:**.....

**Phone:**..... **Fax:**.....

**Monthly Spend A\$**.....

**Name:**.....

**Address:**.....

**Phone:**..... **Fax:**.....

**Monthly Spend A\$**.....

**Name:**.....

**Address:**.....

**Phone:**..... **Fax:**.....

**Monthly Spend A\$**.....

**PLEASE READ CAREFULLY BEFORE SIGNING**

I/We the undersigned hereby request that TIC (Retail Accessories) supply goods to me in consideration of TIC (Retail Accessories) agreeing to do so. I/We hereby jointly and severally warrant to and covenant with TIC (Retail Accessories) as follows;

1. That all information contained herein is true and correct in every particular and that all material facts have been disclosed to TIC (Retail Accessories).
2. That payments for all goods supplied by TIC (Retail Accessories) will be made strictly in accordance with the trading terms applicable from time to time.
3. If the applicant is a company then provision of a trading account pursuant to this application is subject to and conditional upon the applicant's directors executing a Guarantee in the form approved.
4. The undersigned and any director or principal of the applicant have never been made bankrupt and are solvent and are able to pay their debts as they fall due and have not made any compromise or arrangement with their creditors and no application has been made or proposed to a summon meeting of their creditors or any class of them.
5. That the applicant (if a corporation) is solvent and able to pay its debts as they fall due and is not in liquidation or being wound up and no meeting has been called or resolution has been passed or order made for such purposes and no Receiver or Receiver Manager has been appointed in respect of the applicant and the applicant has not made any compromise or arrangement with its creditors or any class of them and no application has been proposed or made to any court for an order summoning a meeting of its creditors or any class of them.
6. That the applicant hereby acknowledges receipt for TIC (Retail Accessories) Terms of Trade, as they presently exist.

Dated the:..... day of.....20.....

SOLE TRADER (SIGNATURE):.....

PARTNERS (SIGNATURE):.....

THE COMMON SEAL of )  
was hereunto affixed )  
in accordance with its Articles of )  
Association in the presence of )

.....Director

.....Secretary

TIC (Retail Accessories) Pty Ltd.  
51 Regan Street, St. Albans, Victoria, Australia 3021

**Your Authorised TIC Webpage Password .....**

IN CONSIDERATION of you having agreed or agreeing to sell goods or provide services or extend credit to the party named in the Schedule hereto as the debtor (herein after called "the debtor" we, the parties named in the Schedule hereto as he Guarantors JOINTLY AND SEVERALLY GUARANTEE the due and punctual payment to you by the debtor of all monies now and hereafter payable to the debtor to you on any account whatsoever whether such sale, provision or extension shall have occurred or been made before or after the execution of this instrument and whether or not the said agreement to sell goods, provide services or extend credit, may be or become void or voidable or unenforceable by law. WE JOINTLY AND SEVERALLY INDEMINIFY you against all loss and damage suffered by you by reason of a failure of the debtor duly to perform any obligation on its part arising out of or in connection with such sale, provision or extension AND WE EXPRESSLY ACKNOWLEDGE AND DECLARE that this Guarantee is given upon the following conditions:

1. The certificate of your Secretary, Credit Manager or Solicitors for the time being stating the amount or amounts due and owing to you by the debtor in relation to such sale, provision or extension shall be conclusive evidence of the indebtedness of the debtor to you as the date stated in such certificate.
2. Our liability to you hereafter shall not be affected by time or any other indulgence granted to you by the debtor or by modification or variation in the terms of sale, provision or extension. You may at such time as you think fit cease to sell goods to or provide services for or extend credit to the debtor.
3. The guarantee hereby given shall be a continuing guarantee and shall bind our executors and administrators.
4. Any demand on us hereunder may be duly made if it is in writing signed by your Secretary, Credit Manager or Solicitors and is given to or left for us at or posted to one of our addresses set out as below or to such other addresses as we may from time to time notify you in writing, PROVIDED THAT it shall not be a condition precedent to the exercise of your rights against us hereunder that any demand or notice will be given to us.
5. Except where the context forbids words herein importing the plural shall include the singular and vice versa.
6. Until you have received 100 cents in the dollar in respect of the Guarantee obligations the Guarantor shall not be entitled either directly or indirectly receive the benefit from the administration of the affairs of the debtor in insolvency resulting from the lodging of any proof or make nay claim in respect thereof in competition with you so as to diminish any amount that but for such dividend or other payment that you may receive shall not prejudice your right to recover so much of the guaranteed amounts as have not been paid to you.
7. No monies received by you to the creditor of the debtor and for which you may in any administration in insolvency of the affairs as the debtor be obliged to account to any liquidator, official manager, trustee in bankruptcy may in your discretion be received by you discharge or diminish our liability hereunder.

## Conditions of Sale

### **Interpretation**

1. In these conditions:  
‘Seller’ means [Tic (Retail Accessories) Pty Ltd] which is the seller of the goods.  
‘Buyer’ means the purchaser of the goods specified overleaf.  
‘Goods’ means the products and, if any, services specified overleaf.  
Nothing in these conditions shall be read or applied so as to exclude, restrict or modify or have the effect of excluding, restricting or modifying any condition, warranty, guarantee, right or remedy implied by law (including the Trade Practices Act 1974) and which by law cannot be excluded, restricted or modified.

### **General**

2. These conditions (which shall only be waived in writing signed by the seller) shall prevail over all conditions of the buyer’s order to the extent of any inconsistency.

Important note: A number of garment hangers, accessories and supporting devices are the subject of Intellectual Property Rights owned by TIC Group Pty Ltd. and/or its affiliates. Any breach of these rights may be the subject of legal action.

**Disclaimer:** Suppliers have a duty of care to ensure hangers and accessories selected from the TIC range can withstand the particular transport, distribution and handling environments they will be subjected to. Please contact TIC if you require assistance with the selection of hangers or accessories.

### **Terms of sale**

3. The goods and all other products sold by seller are sold on these terms and conditions.

### **Seller’s quotations**

4. Unless previously withdrawn, seller’s quotations are open for acceptance within the period stated in them or, when no period is so stated, within 30 days only after its date. The seller reserves the right to refuse any order based on this quotation within 7 days after the receipt of the order.

### **Packing**

5. The cost of any special packing and packing materials used in relation to the goods are at the buyer’s expense notwithstanding that such cost may have been omitted from any quotation.

### **Shortage**

6. The buyer waives any claim for shortage of any goods delivered if a claim in respect for short delivery has not been lodged with the seller within seven (7) days from the date of receipt of goods by the buyer.

### **Delivery**

7. (a) The delivery times made known to the buyer are estimates only and the seller is not be liable for late delivery or non-delivery.  
(b) The seller is not be liable for any loss, damage or delay occasioned to the buyer or its customers arising from late or non-delivery or late installation of the goods.  
(c) The seller may at its option deliver the goods to the buyer in any number of instalments unless there is an endorsement overleaf to the effect that the buyer will not take delivery by instalments.  
(d) If the seller delivers any of the goods by instalments, and any one of those instalments is defective for any reason:
  - (1) it is not a repudiation of the contract of sale formed by these conditions; and
  - (2) the defective instalment is a severable breach that gives rise only to a claim for compensation.

### **Loss or damage in transit**

8. (a) The seller is not responsible to the buyer or any person claiming through the buyer for any loss or damage to goods in transit caused by any event of any kind by any person (whether or not the seller is legally responsible for the person who caused or contributed to that loss or damage).  
(b) The seller must provide the buyer with such assistance as may be necessary to press claims on carriers so long as the buyer:
  - (1) has notified the seller and the carriers in writing immediately after loss or damage is discovered on receipt of goods; and
  - (2) lodges a claim for compensation on the carrier within three (3) days of the date of receipt of the goods.

### **Prices**

9. (a) Unless otherwise stated all prices quoted by the seller are net, exclusive of Goods and Services Tax (GST).  
(b) Prices quoted are those ruling at the date of issue of quotation and are based on rates of freight, insurance, customs duties, exchange, shipping expenses, sorting and stacking charges, cartage, rate of wates, cost of materials and other charges affecting the cost of production ruling on the date is made.  
(c) If the seller makes any alterations to the price of the goods or to any of their inputs either before acceptance of or during the currency of the contract, these alterations are for the buyer’s account.

**Payment**

10. The purchase price in relation to goods is payable net and payment of the price of the goods must be made on or before thirty days from date of the delivery of the goods unless other terms of payment are expressly stated in these conditions in writing.

**Rights in relation to goods**

11. The seller reserves the following rights in relation to the goods until all accounts owed by the buyer to the seller are fully paid:

- (1) ownership of the goods;
- (2) to enter the buyer’s premises (or the premises of any associated company or agent where the goods are located) without liability for trespass or any resulting damage and retake possession of the goods; and
- (3) to keep or resell any goods repossessed pursuant to (2) above.

If the goods are resold by the buyer, the buyer shall hold such part of the proceeds of any such sale as represents the invoice price of the goods sold in a separate identifiable account as the beneficial property of the seller and shall pay such amount to the seller upon request. Notwithstanding the provisions above the seller shall be entitled to maintain an action against the buyer for the purchase price and the risk of the goods shall pass to the buyer upon delivery.

**Buyer’s property**

12. Any property of the buyer under the seller’s possession, custody or control is completely at the buyer’s risk as regards loss or damage caused to the property or by it.

**Storage**

13. The seller reserves the right to make a reasonable charge for storage if delivery instructions are not provided by the buyer within fourteen days of a request by the seller for such instructions. The parties agree that the seller may charge for storage from the first day after the seller requests the buyer to provide delivery instructions.

**Returned goods**

- 14. (a) The seller is not be under any duty to accept goods returned by the buyer and will do so only on terms to be agreed in writing in each individual case.
- (b) If the seller agrees to accept returned goods from the buyer under para (a) of this clause, the buyer must return the goods to the seller at the seller’s place of business referred to at the head of these conditions.

**Goods sold**

15. All goods to be supplied by the seller to the buyer are as described on the purchase order agreed by the seller and the buyer and the description on such purchase order modified as so agreed prevails over all other descriptions including any specification or enquiry of the buyer.

**Cancellation**

16. No order may be cancelled except with consent in writing and on terms which will indemnify the seller against all losses.

**Default**

17. If the Buyer defaults in payment of any monies due to the Seller the Buyer shall at the option of the Seller pay to the Seller interest on the monies in respect of which default in payment has been made calculated at the daily rate being the rate prescribed from time to time pursuant to the Penalty Interest Rates Act 1983 plus 4% together with and in addition to all costs and expenses including legal costs on a solicitor/client basis incurred by the Seller in recovering from the Buyer monies due as a consequence of the default by the Buyer in payment of monies on the due date for payment.

**Place of contract**

- 18 (a) The contract for sale of the goods is made in the State of Victoria.
- (b) The parties submit all disputes arising between them to the courts of the State of Victoria and any court competent to hear appeals from those courts of first instance.

Signed \_\_\_\_\_ Position \_\_\_\_\_

Dated \_\_\_\_\_



# TIC Group – Ningbo Office

(Represented by Ningbo Xunxing Trade Co Ltd)

No 15, Chuang Ye Da Dao,

West District off Free Trade Zone, Ningbo, China

Tel: +86 574 2687 3733

Fax: +86 574 8682 3880

Email: hangers.cn@ticgroupasia.com

## REGISTRATION FOR CHINA, SOUTH EAST ASIA, INDIAN, SUB-CONTINENT AND EUROPEAN BASED MANUFACTURERS AND AGENTS

TRADING DETAILS:

ABN: .....

Trading Name:.....

Trading Address:.....

.....Postcode/Zip Code:.....

Phone:.....Fax:.....

Email:.....

### COMPANY DETAILS (Complete this Section)

**Company**

**Name:**.....

**Registered**

**Address:**.....

.....**Phone:**.....

**Business License Number:**.....

### DETAILS OF DIRECTORS:

**Name:**.....

**Private**

**Address:**.....

**Phone:**.....

**Name:**.....

**Private**

**Address:**.....

**Phone:**.....

**BANK DETAILS:**  
**Monthly Credit Applied For:**.....  
**Anticipated Annual Spend:** .....  
**Bank:**.....**Branch:**.....  
**Account Name:**.....  
**Account Number:**.....

**Monthly Credit Applied For:**.....  
**Anticipated Annual Spend US\$:**.....

**PLEASE READ CAREFULLY BEFORE SIGNING**

1. Credit will only be given to Target suppliers that have been approved by Target.
2. All other suppliers must pre-pay for their hangers and accessories.
3. TIC Group (Asia) reserves the right to withhold deliveries of hangers and accessories if the supplier has not pre-paid for their hangers and accessories.
4. TIC Group (Asia) reserves the right to withhold deliveries of hangers and accessories if a supplier granted credit has not settled outstanding invoices within 30 days of the invoice being issued.

Dated the:..... day of.....20.....

COMPANY CHOP HERE

TIC Group – Ningbo Office (Represented by Ningbo Xunxing Trade Co Ltd)  
 No 15, Chuang Ye Da Dao, West District of Free Trade Zone, Ningbo, China

**Your Authorised TIC Webpage Password .....**

## Conditions of Sale

### Interpretation

1. In these conditions:  
'Seller' means TIC Group (Asia) Ltd. which is the seller of the goods.  
'Buyer' means the purchaser of the goods specified overleaf.  
'Goods' means the products and, if any, services specified overleaf.

### General

2. These conditions (which shall only be waived in writing signed by the seller) shall prevail over all conditions of the buyer's order to the extent of any inconsistency.

Important note: A number of garment hangers, accessories and supporting devices are the subject of Intellectual Property Rights owned by TIC Group Pty Ltd. and/or its affiliates. Any breach of these rights may be the subject of legal action.

**Disclaimer:** Suppliers have a duty of care to ensure hangers and accessories selected from the TIC range can withstand the particular transport, distribution and handling environments they will be subjected to. Please contact TIC if you require assistance with the selection of hangers or accessories.

### Terms of sale

3. The goods and all other products sold by seller are sold on these terms and conditions.

### Seller's quotations

4. Unless previously withdrawn, seller's quotations are open for acceptance within the period stated in them or, when no period is so stated, within 30 days only after its date. The seller reserves the right to refuse any order based on this quotation within 7 days after the receipt of the order.

### Packing

5. The cost of any special packing and packing materials used in relation to the goods are at the buyer's expense notwithstanding that such cost may have been omitted from any quotation.

### Shortage

6. The buyer waives any claim for shortage of any goods delivered if a claim in respect for short delivery has not been lodged with the seller within seven (7) days from the date of receipt of goods by the buyer.

### Delivery

7. (a) The delivery times made known to the buyer are estimates only and the seller will not be liable for late delivery or non-delivery.  
(b) The seller will not be liable for any loss, damage or delay occasioned to the buyer or its customers arising from late or non-delivery or late installation of the goods.  
(c) The seller may at its option deliver the goods to the buyer in any number of installments unless there is an endorsement overleaf to the effect that the buyer will not take delivery by installments.  
(d) If the seller delivers any of the goods by installments, and any one of those installments is defective for any reason:
  - (1) it is not a repudiation of the contract of sale formed by these conditions; and
  - (2) the defective installment is a severable breach that gives rise only to a claim for compensation.

### Loss or damage in transit

8. (a) The seller is not responsible to the buyer or any person claiming through the buyer for any loss or damage to goods in transit caused by any event of any kind by any person (whether or not the seller is legally responsible for the person who caused or contributed to that loss or damage).  
(b) The seller must provide the buyer with such assistance as may be necessary to press claims on carriers so long as the buyer:
  - (1) has notified the seller and the carriers in writing immediately after loss or damage is discovered on receipt of goods; and
  - (2) lodges a claim for compensation on the carrier within three (3) days of the date of receipt of the goods.

### Prices

9. (a) Prices quoted are those ruling at the date of issue of quotation and are based on rates of freight, insurance, customs duties, exchange, shipping expenses, sorting and stacking charges, cartage, rate of wastes, cost of materials and other charges affecting the cost of production ruling on the date is made.  
(b) If the seller makes any alterations to the price of the goods or to any of their inputs either before acceptance of or during the currency of the contract, these alterations are for the buyer's account.

### Payment

10. The purchase price in relation to goods is payable net and payment of the price of the goods must be made on or before thirty days from date of the delivery of the goods unless other terms of payment are expressly stated in these conditions in writing.

**Rights in relation to goods**

11. The seller reserves the following rights in relation to the goods until all accounts owed by the buyer to the seller are fully paid:

- (1) ownership of the goods;
- (2) to enter the buyer's premises (or the premises of any associated company or agent where the goods are located) without liability for trespass or any resulting damage and retake possession of the goods; and
- (3) to keep or resell any goods repossessed pursuant to (2) above.

If the goods are resold by the buyer, the buyer shall hold such part of the proceeds of any such sale as represents the invoice price of the goods sold in a separate identifiable account as the beneficial property of the seller and shall pay such amount to the seller upon request. Notwithstanding the provisions above the seller shall be entitled to maintain an action against the buyer for the purchase price and the risk of the goods shall pass to the buyer upon delivery.

**Buyer's property**

12. Any property of the buyer under the seller's possession, custody or control is completely at the buyer's risk as regards loss or damage caused to the property or by it.

**Storage**

13. The seller reserves the right to make a reasonable charge for storage if delivery instructions are not provided by the buyer within fourteen days of a request by the seller for such instructions. The parties agree that the seller may charge for storage from the first day after the seller requests the buyer to provide delivery instructions.

**Returned goods**

14. (a) The seller is not under any duty to accept goods returned by the buyer and will do so only on terms to be agreed in writing in each individual case.
- (b) If the seller agrees to accept returned goods from the buyer under paragraph (a) of this clause, the buyer must return the goods to the seller at the seller's place of business referred to at the head of these conditions.

**Goods sold**

15. All goods to be supplied by the seller to the buyer are as described on the purchase order agreed by the seller and the buyer and the description on such purchase order modified as so agreed prevails over all other descriptions including any specification or enquiry of the buyer.

**Cancellation**

16. No order may be cancelled except with consent in writing and on terms which will indemnify the seller against all losses.

Signed \_\_\_\_\_ Position \_\_\_\_\_

Dated \_\_\_\_\_



## LINGERIE

### WOMEN

**LH34BL - 250mm (Black)**

► Swimwear & activewear

**LH34CR - 250mm (Crystal)**

► Briefs and Bras

**LH85BL - 270mm**

► Swimwear & activewear

**LH85CR - 270mm (Crystal)**

► Briefs, Bras, Camisoles & Underwear sets.

**LH89CR - 270mm (Crystal)**

► Briefs and Bras.

**LH76CR - 310mm (Crystal)**

► Briefs and Bras

**BR32CR - 285mm (Crystal)**

► Bras

**BR33CR - 335mm (Crystal)**

► Bras

**BR88CR - 225mm (Crystal)**

► 2 piece garments

### MEN

**LH34BL - 250mm (Black)**

► Briefs and swimwear

**LH85BL - 270mm (Black)**

► Briefs and swimwear

### CHILDREN

**LH35BL - 200mm (Black)**

► Briefs, camisole and underwear sets

**LH75 - 210mm**

► Briefs, camisole and underwear sets

## FOOTWEAR

**FW24 - 115mm**

► Thongs

**FW23 - 70mm**

► Childrens casual, canvas, court shoes

**FW22 - 90mm**

► Casual, canvas, court shoes

**FW75 - 120mm**

► Adult casual, canvas, court shoes

**FW25 - 170mm**

► Multi purpose shoes, slippers and scuffs

**FW77 - 195mm**

► Multi purpose shoes, slippers and scuffs

**FW26 - 215mm**

► Long multi purpose shoes, slippers and scuffs

**FW80 - 295mm**

► Long multi purpose shoes, slippers and scuffs

**FW92 - 280mm**

► Multi-purpose larger shoes

**FW78 - 180mm**

► Boots

**FW79N - 130mm**

► Boots

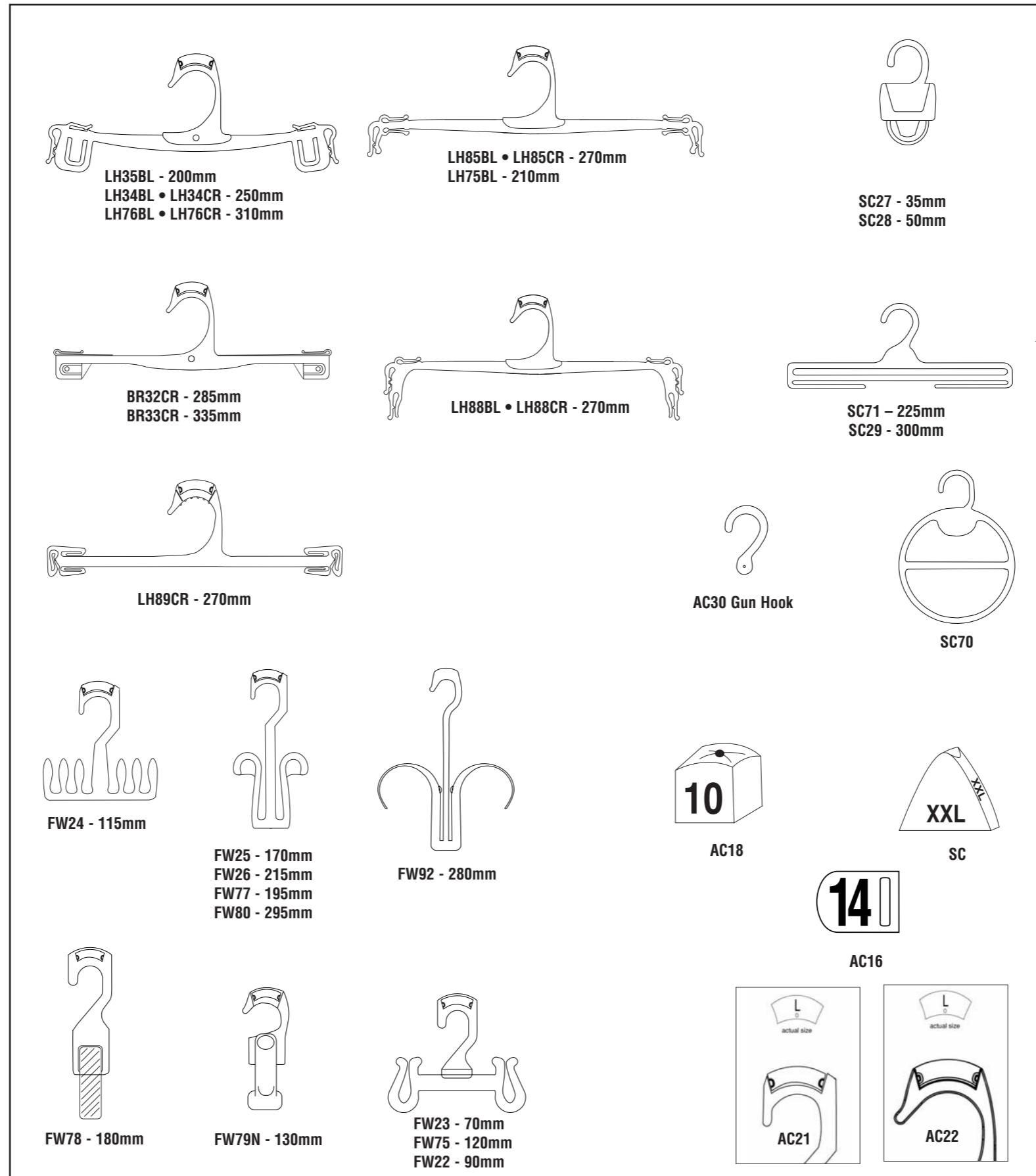

## SCARVES

**SC27 - 35mm**

► Small

**SC28 - 50mm**

► Large

**SC29 - 300mm**

► Shawls and scarves

**SC71 - 225mm**

► Shawls and scarves

**SC70 - Round**

► Shawls and scarves

**AC30 - Gun Hook**

►

## SIZE CLIPS

**AC16 - Size Clips**

►

**AC18 - Size Clip**

► Metal hook

**AC21 - Footwear Size Tab**

►

**AC22 - Lingerie Size Tab**

►

**SC - Sizer**

► for KU45



## HANGER INDEX

Category	Code	Colour	Description	
Tops	TH40X	Black	250 mm Children's Upper Body	
	TH40X	Warm Grey	250 mm Children's Upper Body	
	TH41X	Black	300 mm Children's Upper Body	
	TH41X	Warm Grey	300 mm Children's Upper Body	
	TH42X	Black	350 mm Children's Upper Body	
	TH43	Black	400 mm Adult's Upper Body	
	TH43	Natural	400 mm Adult's Upper Body	
	TH45	Black	460 mm Adult's Upper Body	
	TH45	Natural	460 mm Adult's Upper Body	
	TH46	Black	520mm Adult's Upper Body	
	KN44	Black	420mm Adults' Knitwear	
	KN44	Natural	420mm Adults' Knitwear	
	KN47	Black	460 mm Adult's Knitwear	
	AC67	Dark Grey	Foam Sleeves	
	AC67C	Dark Grey	Childrens Foam Sleeves	
	SU65	Black	460mm Suit Hanger	
	SU86	Black	460mm Jacket Hanger	
	4489	Black	420mm Jacket Hanger	
	Bottoms	PH54X	Black	190mm Children's Lower Body Prong
		PH54X	Warm Grey	190mm Children's Lower Body Prong
PH54XL		Black	190mm Children's Lower Body Prong With Loop	
PH54XL		Warm Grey	190mm Children's Lower Body Prong With Loop	
PH55X		Black	260mm Children's Lower Body Prong	
PH55XL		Black	260mm Children's Lower Body Prong With Loop	
BH60		Black	210mm Children's Lower Body Clip	
BH64		Black	260mm Children's Lower Body Clip	
BH61		Black	280mm Children's Lower Body Clip	
BH61		Natural	280mm Children's Lower Body Clip	
BH61L		Black	280mm Children's Lower Body Clip With Loop	
BH62		Black	310mm Adult's Lower Body Clip	
BH62		Natural	310mm Adult's Lower Body Clip	
BH63		Black	350mm Adult's Lower Body Clip	
FL57		Black	280mm Adult's Lower Body Fox Lock	
FL58		Black	310mm Adult's Lower Body Fox Lock	
FL59		Black	350mm Adult's Lower Body Fox Lock	
BSL82		Black	310mm Adult's Lower Body Soft Lock Peg	
BH81X		Black	340mm Adult's Lower Body Trouser	
Frame		FR78	Black	250mm x 320mm
	FR79	Black	250mm x 350mm	
	FR80	Black	350mm x 430mm	
	TH40DS	Black	155mm x 250mm	
	TH40DS	Warm Grey	155mm x 250mm	
	TH41DS	Black	155mm x 300mm	
	TH41DS	Warm Grey	155mm x 300mm	
	TH42DS	Black	155mm x 350mm	
	TP95	Black	210mm 5 Prong Multit Hanger	
	TP90	Black	210mm 2 Prong Multi Hanger	
	TP90	Warm Grey	210mm 2 Prong Multi Hanger	
	TP91	Black	210mm 3 Prong Multi Hanger	
	TP91	Warm Grey	210mm 3 Prong Multi Hanger	
	TP89	Black	210mm 1 Prong Multi Hanger	
TP89	Warm Grey	210mm 1 Prong Multi Hanger		
Access.	AC16	ASSTD	Garments Sizing Clip	
	AC16	ASSTD	Garments Sizing Range	
	AC18	ASSTD	Metal Garments Sizing Clip	
	AC18	ASSTD	Metal Garments Sizing Range	



## HANGER INDEX

Category	Code	Colour	Description
Lingerie	LH34 BL	Black	250mm Mens Brief
	LH34 CR	Crystal	250mm Ladies Brief
	LH35 BL	Black	200mm Childrens Brief
	LH76 BL	Black	310mm Mens Brief
	LH76 CR	Crystal	310mm Ladies Brief
	LH89CR	Crystal	270mm Adult Brief & Camisole Hanger
	LH85 BL	Black	270mm Mens Brief
	LH85 CR	Crystal	270mm Ladies Brief
	LH75 BL	Black	210mm Child's Brief, Camisole & sets
	LH88BL	Black	225mm Adult 2 Pkt Underwear
	LH88CR	Crystal	225mm Adult 2 Pkt Underwear
	BR32 CR	Crystal	285mm Bra Hanger
	BR33 CR	Crystal	335mm Bra Hanger
	LH93CR	Crystal	225mm Adult 3 Pkt Underwear
	LH93BL	Black	225mm Adult 3 Pkt Underwear
	AC22	ASSTD	Lingerie Sizing Tabs
	AC22	ASSTD	Lingerie Sizing Range
Footwear	FW24	Black	115mm Thong Hanger
	FW23	Black	70mm Children's U End
	FW22	Black	90mm U End
	FW75	Black	120mm U End
	FW25	Black	170mm Multi Purpose
	FW77	Black	195mm Multi Purpose
	FW26	Black	215mm Multi Purpose
	FW80	Black	295mm Multi Purpose
	FW92	Black	280mm Multi Purpose
	FW78	Black	170mm Boot Hanger
	FW79N	Black	130mm Boot Hanger
	AC21	ASSTD	Footwear Sizing Tabs
	AC21	ASSTD	Footwear Sizing Range
Scarfe	SC27	Black	35mm Small
	SC28	Black	50mm Large
	SC29	Black	Shawl Hanger
	SC71	Black	Shawl Hanger
	AC30	Black	Gun Hook
	AC30	Warm Grey	Gun Hook
	SC70	Black	Scarf Hanger
Access	AC65	Black	90x70mm Hook & Loop
	AC69	Black	152x70 mm Hook & Loop
	AC66	Black	250x70mm Hook & Loop
	AC80	ASSTD	Brand Plate
Premuim	44H52	Black	420mm Premium Top Hanger
	44H53	Black	420mm Premium Top Hanger
	4455	Black	410mm Premium Top Hanger
	4456	Black	460mm Premium Top Hanger
	4473	Black	310mm Premium Soft Lock Clip Hanger
Price Lists			Price List Garment Hangers
			Price List Garment Hangers

**Category** • Children, Youth

**Application** • Shirts, Tops (assorted), Dresses, Knitwear, Jackets, Jump Suits, Overalls, Sleepwear, Spencers, Camisoles and Slips

C O D E

TH40X

TH41X

TH42X

Top Hanger

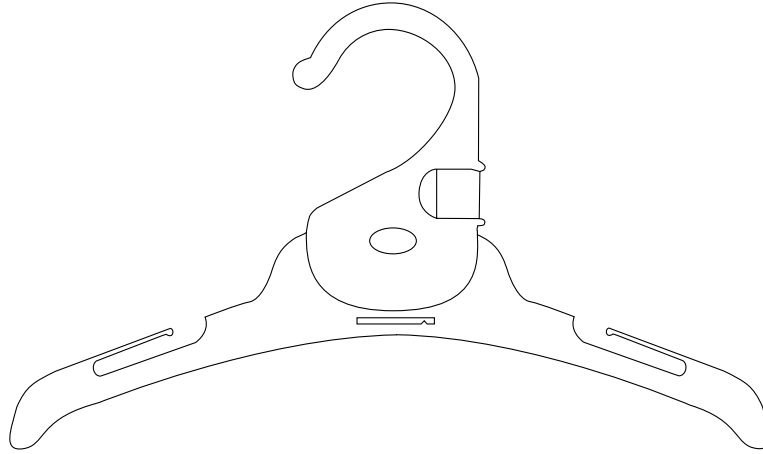

**TH40X**  
**250mm**

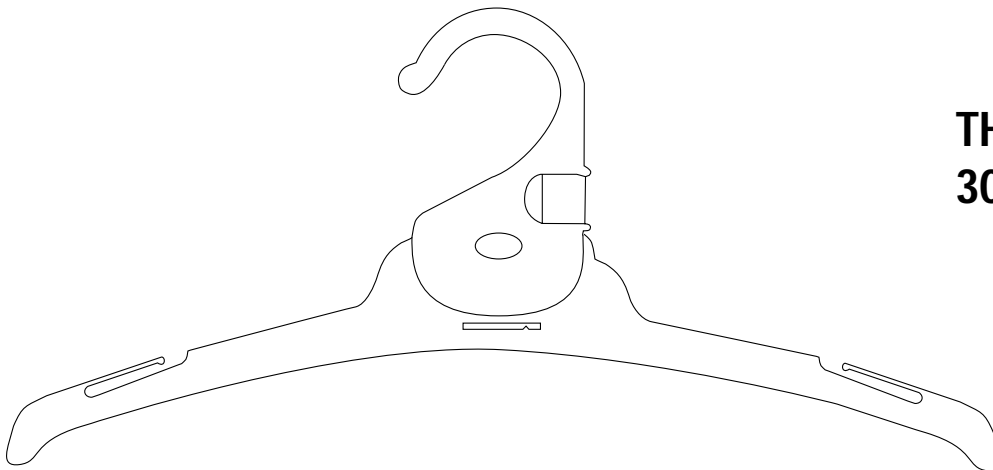

**TH41X**  
**300mm**

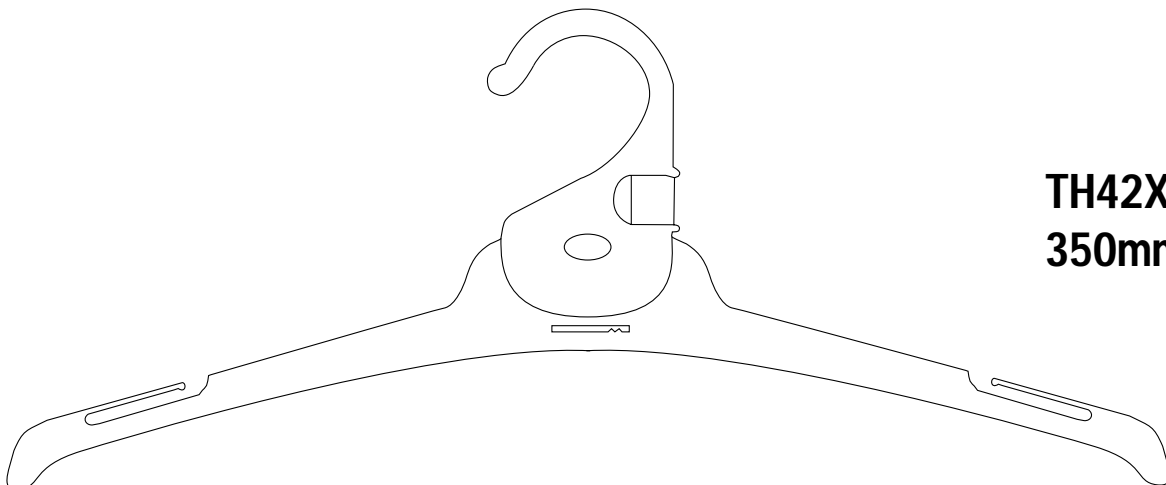

**TH42X**  
**350mm**

C O D E

TH43

TH45

TH46

Top Hanger

**Category** • Children, Adult

**Application** • Shirts, Tops (assorted), Dresses, Lightweight Jackets, Pyjamas, Dressing Gowns, Spencers and Vests

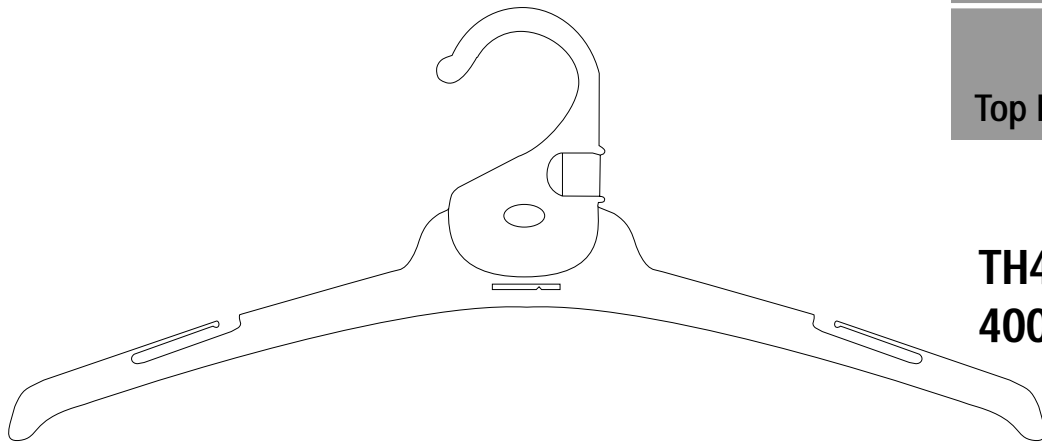

**TH43**  
**400mm**

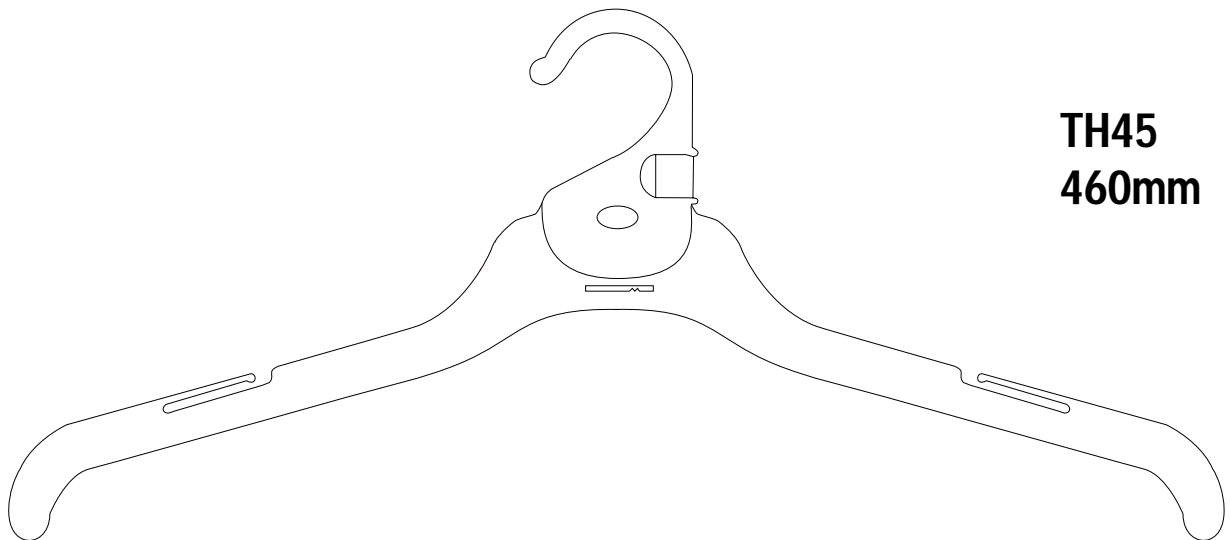

**TH45**  
**460mm**

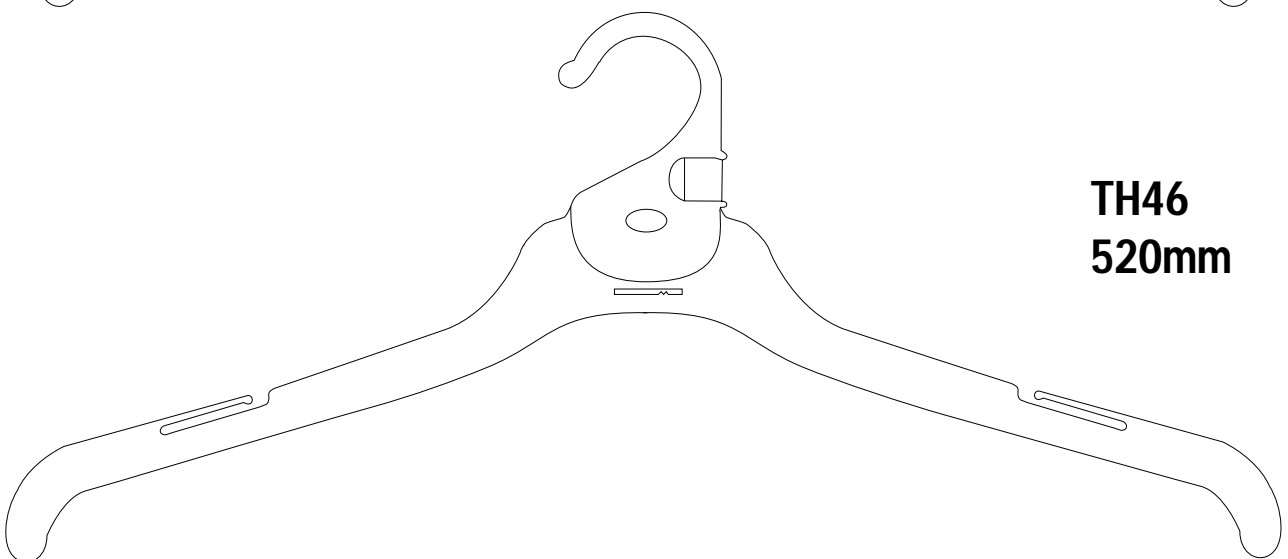

**TH46**  
**520mm**

C O D E

Category • Adult / Youth

Application • Knitwear, Lightweight Jackets, Coats, Parkas  
and Maternity Wear

**KN44**

**KN47**

Knitwear Hanger

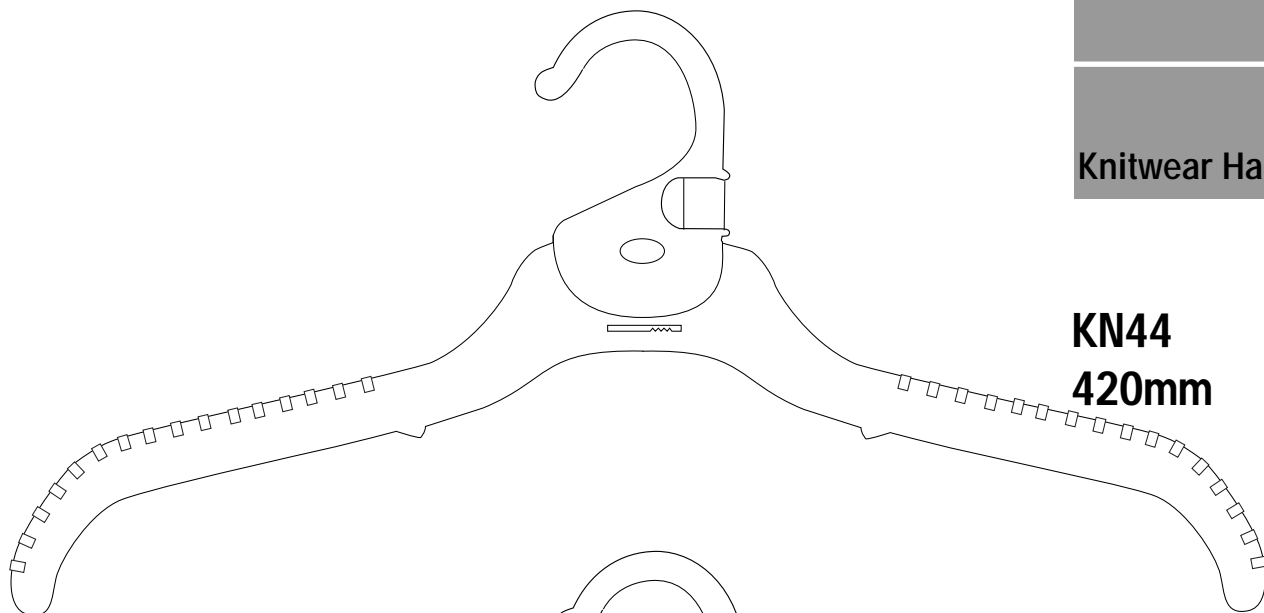

**KN44**  
**420mm**

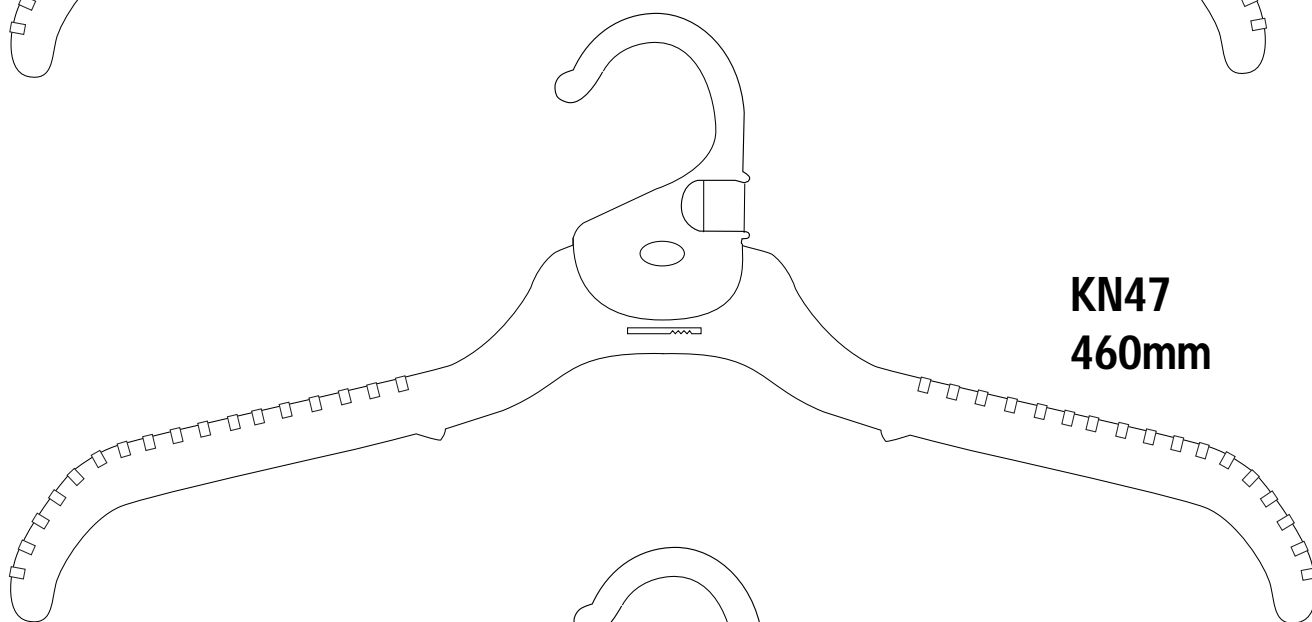

**KN47**  
**460mm**

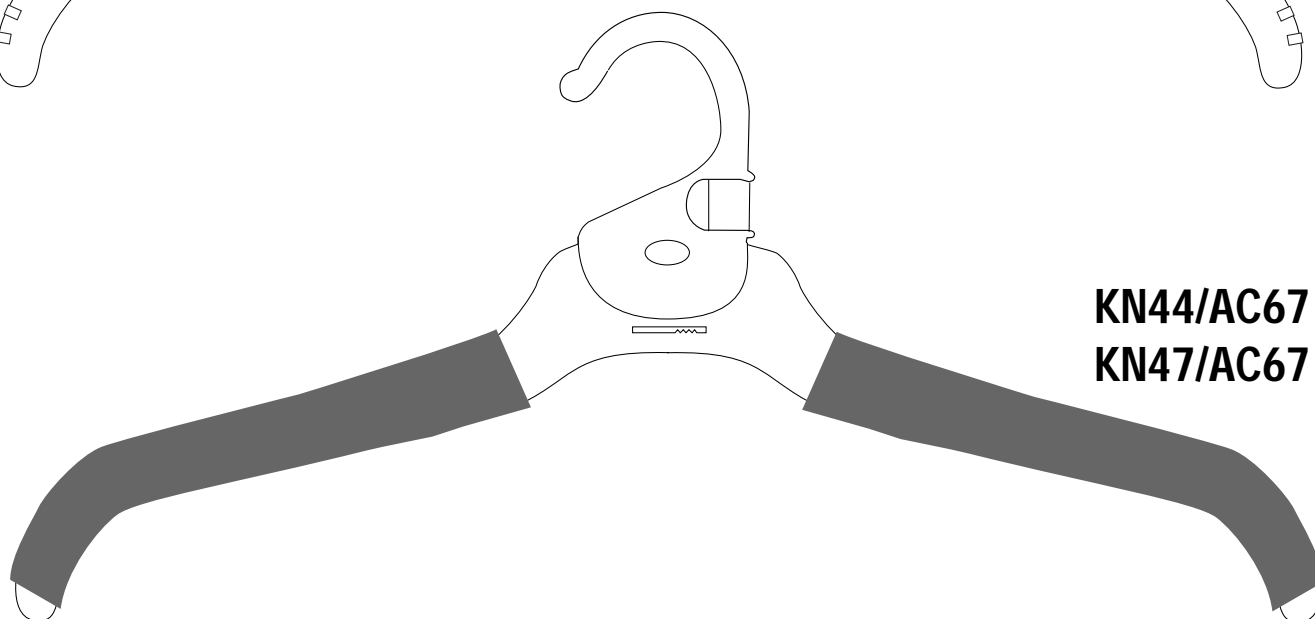

**KN44/AC67**  
**KN47/AC67**

C O D E

AC67

**Category** • Adult

**Application** • For KN44 and KN47 Knitwear Hanger only

**Foam Sleeve  
(Knitwear Hanger)**

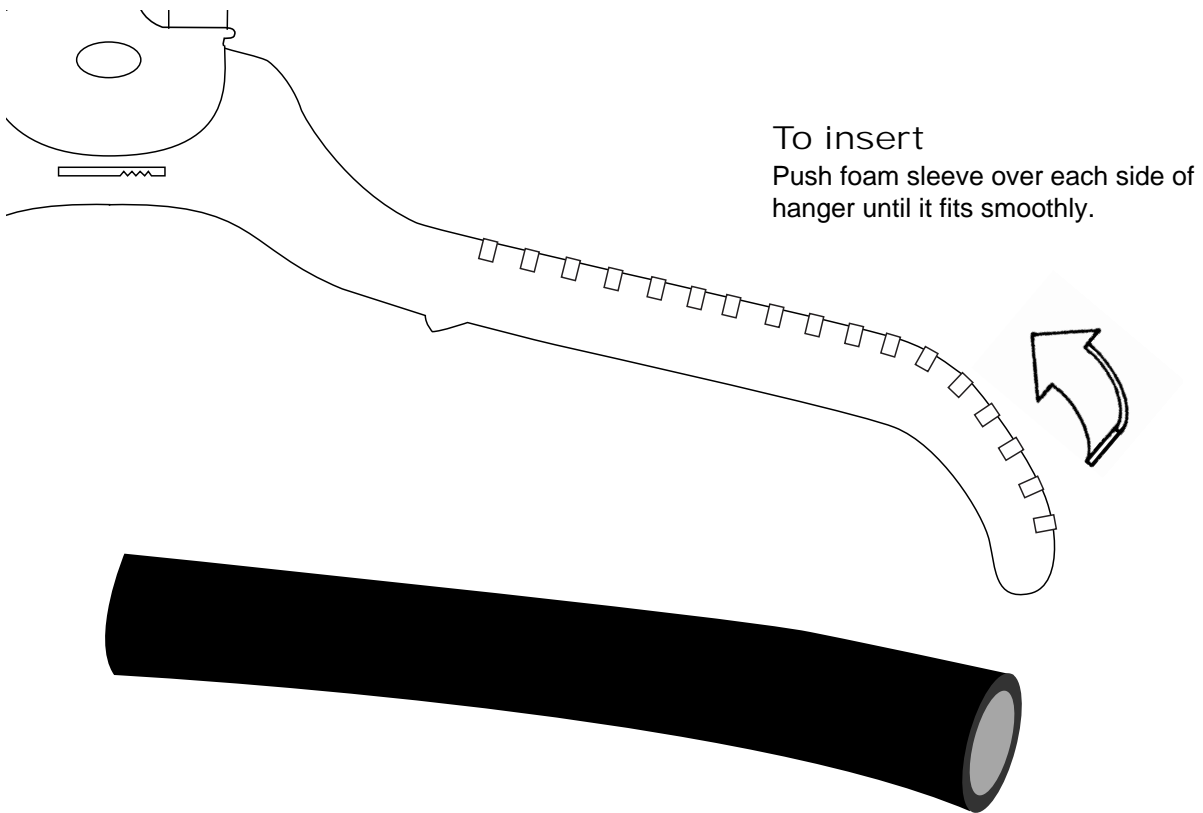

Category • Adult

Application • Jackets, Suits

C O D E

SU65

SU86

4489

Suit Hanger  
and  
Jacket Hanger

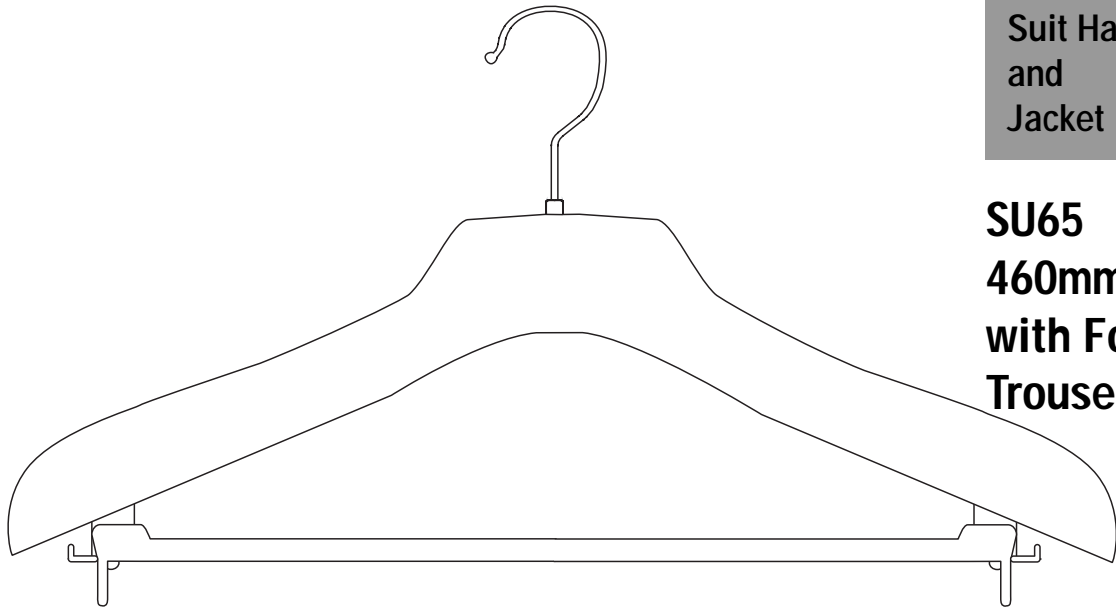

SU65  
460mm  
with Foam on  
Trouser Bar

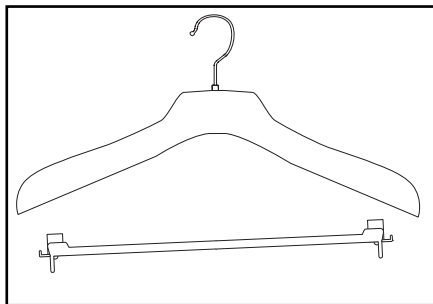

Removable  
trouser bar

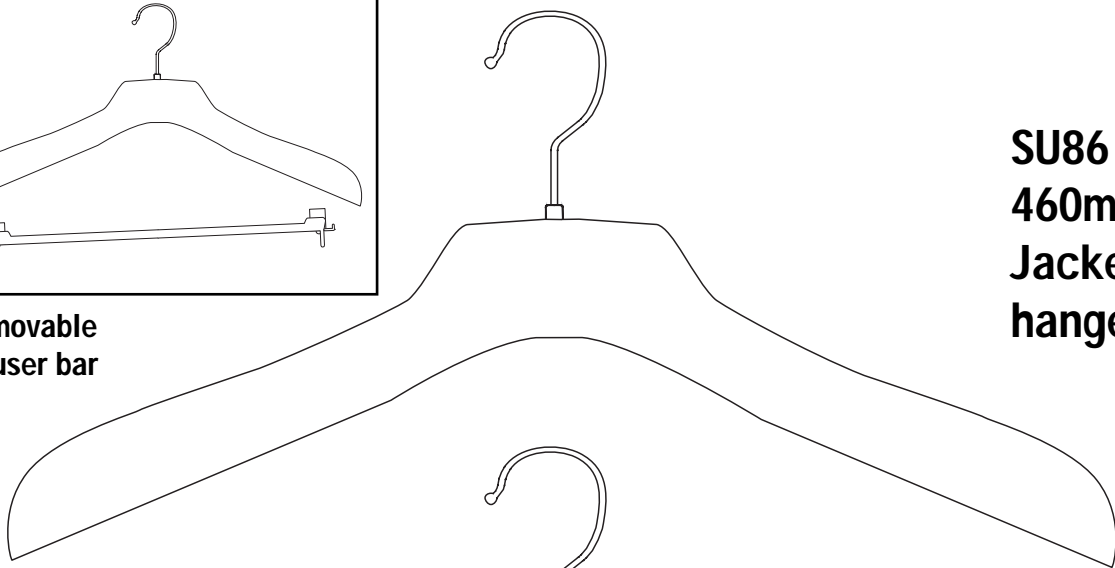

SU86  
460mm  
Jacket  
hanger

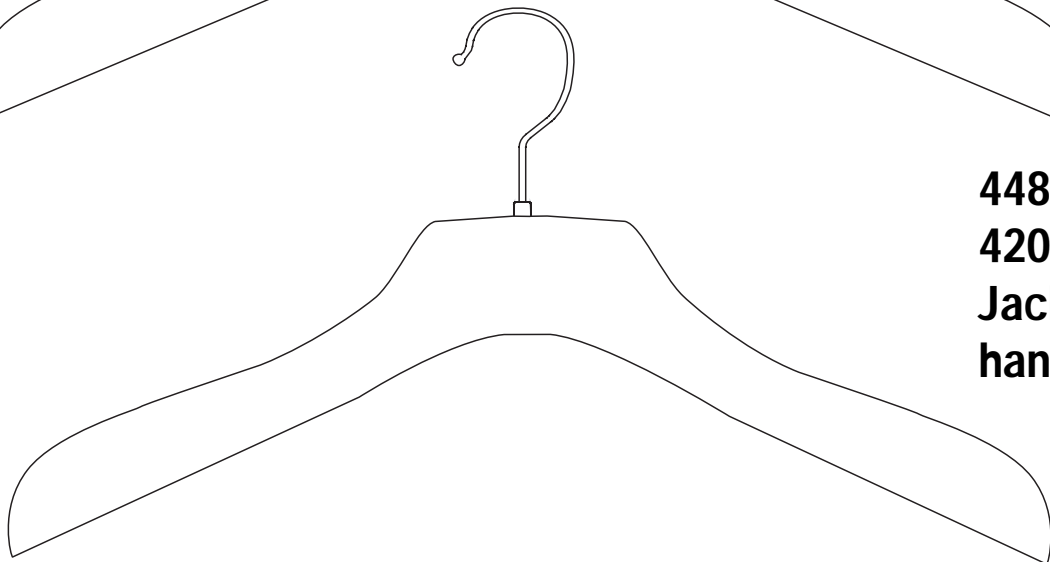

4489  
420mm  
Jacket  
hanger

Category • Children, Adult

Application • Pants, Skirts, Shorts, and Sets

PH54

PH55

Bottom Hanger  
- Prong

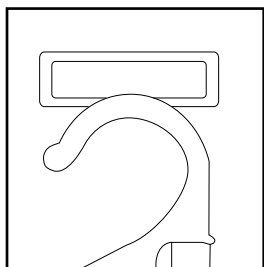

PH54L  
with loop for  
two piece sets

PH54  
190mm

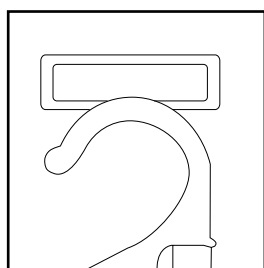
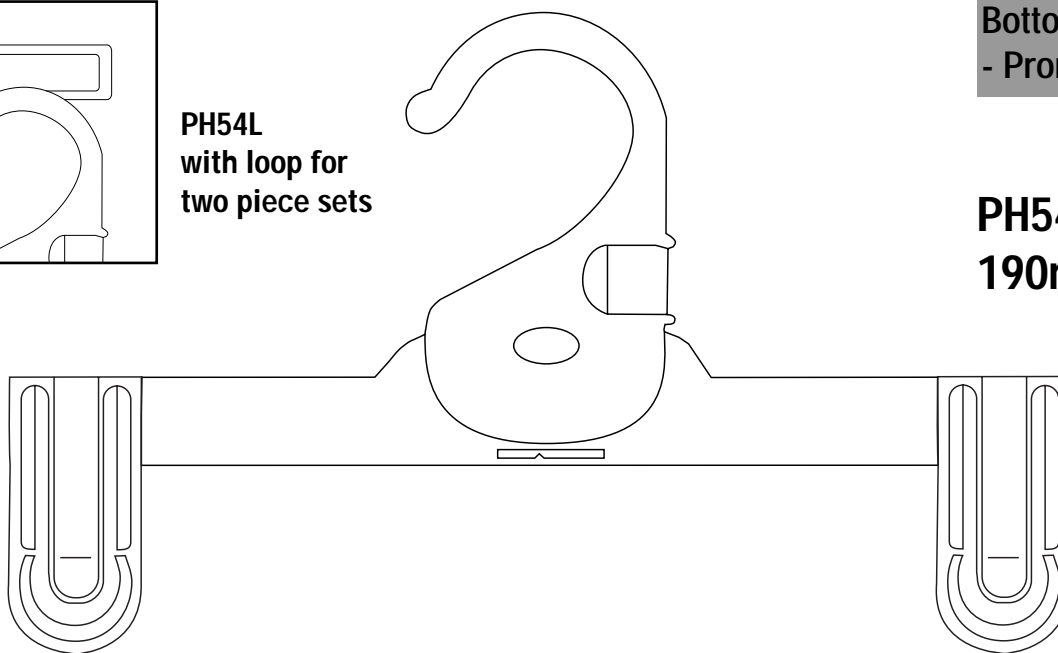

PH55L  
with loop for  
two piece sets

PH55  
260mm

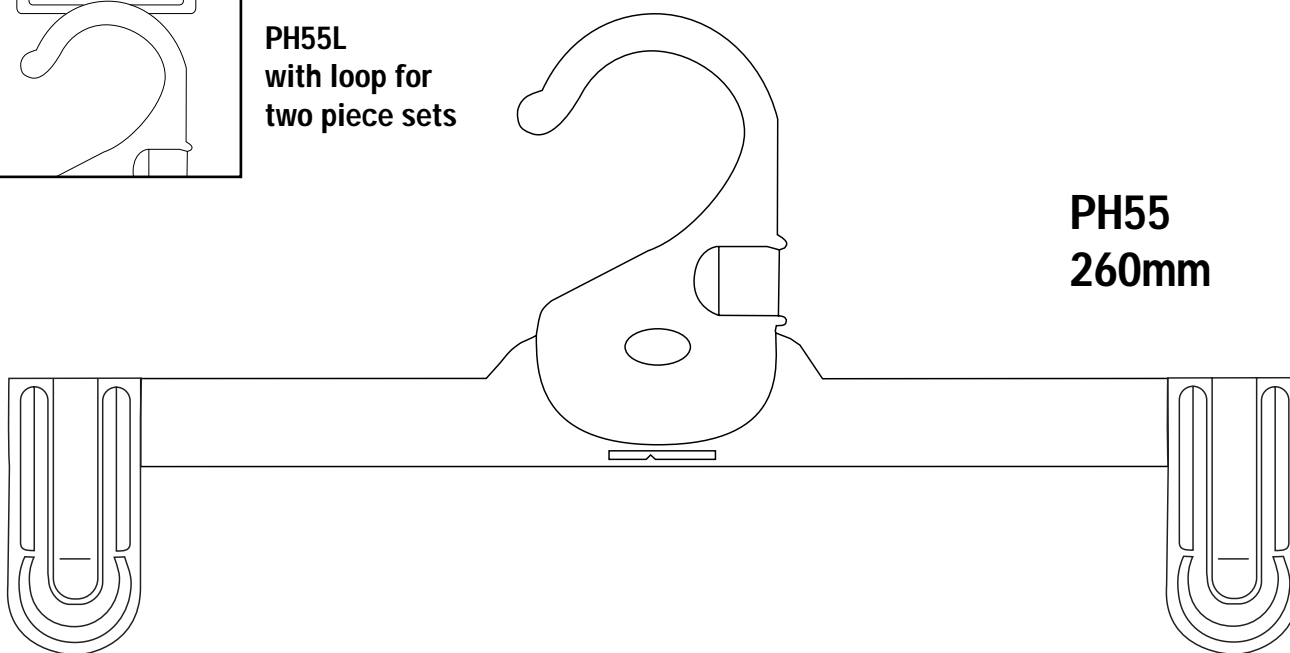

C O D E

Category • Children, Adult

Application • Pants, Skirts, Shorts and Sets

**BH60**

**BH64**

**BH61**

Bottom Hanger  
Low Profile

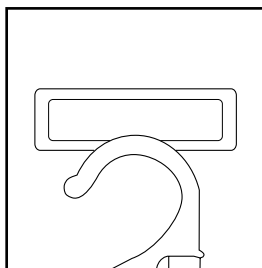
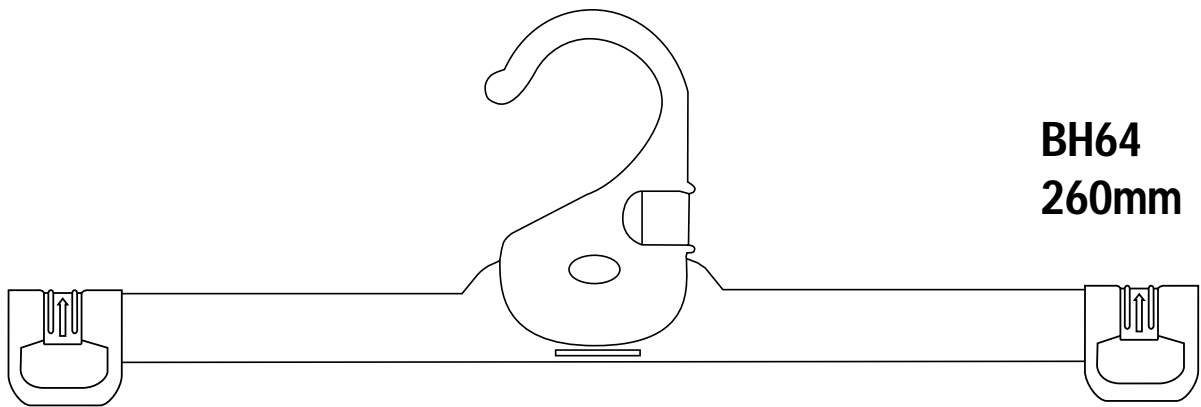
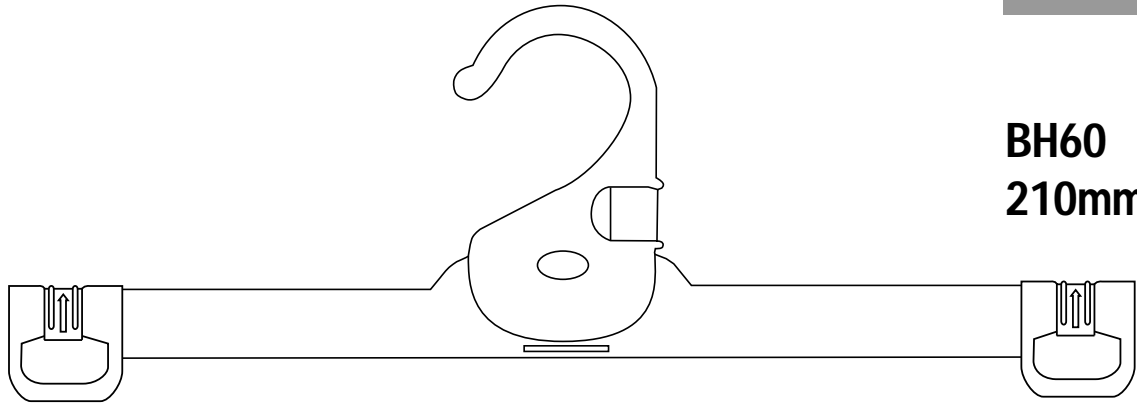

**BH61L**  
with loop for  
two piece sets

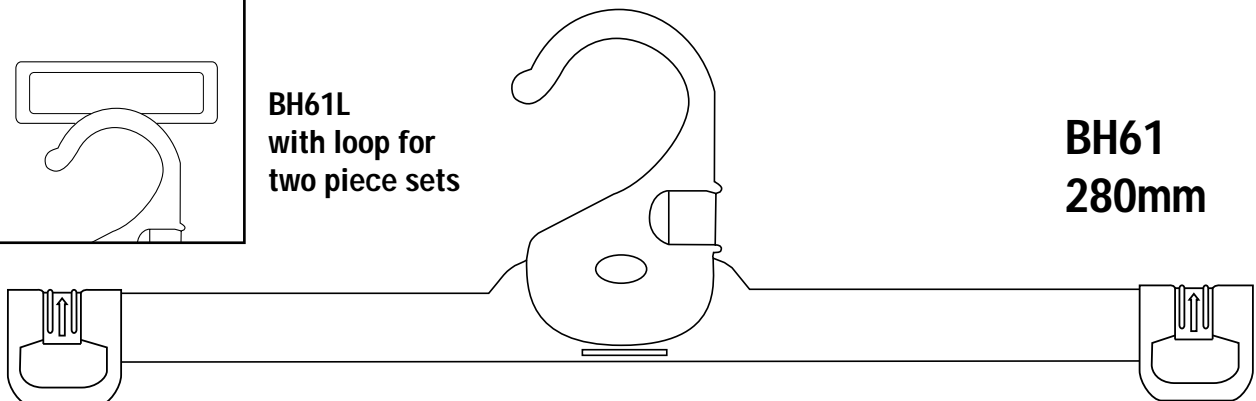

C O D E

Category • Adult

Application • Pants, Skirts, Shorts, etc

**BH62**

**BH63**

Bottom Hanger  
Low Profile

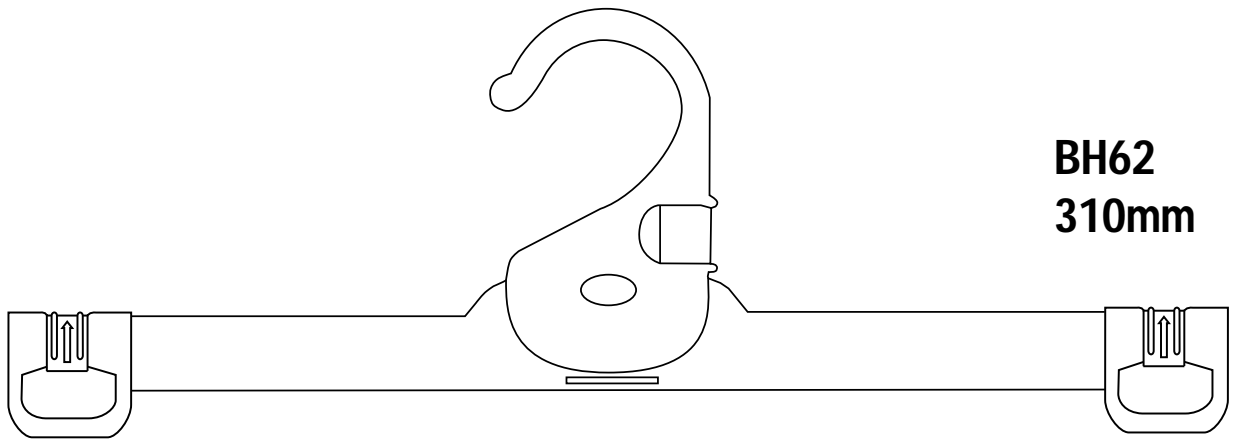

**BH62**  
**310mm**

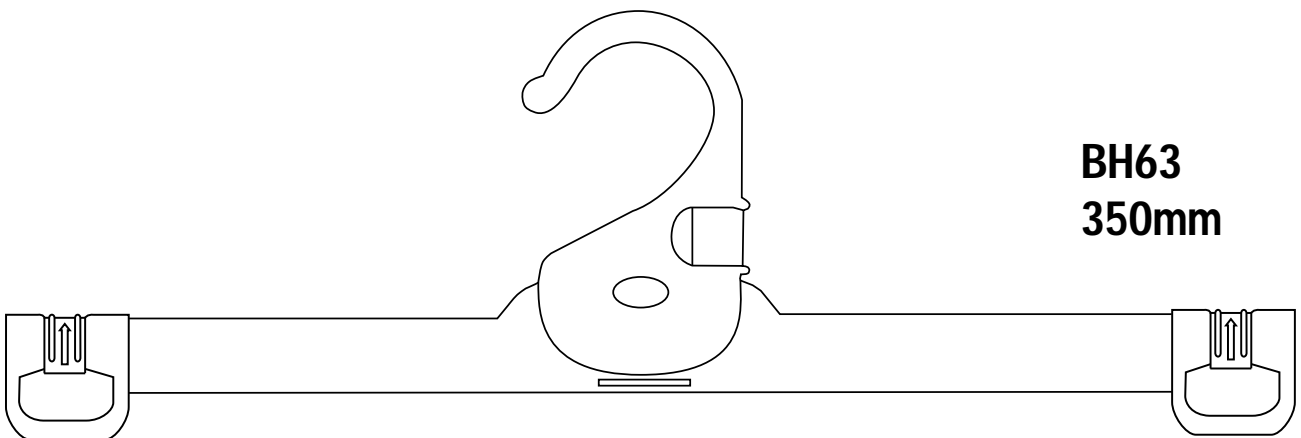

**BH63**  
**350mm**

C O D E

FL57

FL58

FL59

Bottom Hanger  
- Fox Lock

**Category** • Children, Adult

**Application** • Jeans, Pants, Skirts, Shorts, Mens Swimwear,  
Pyjamas and Boxers

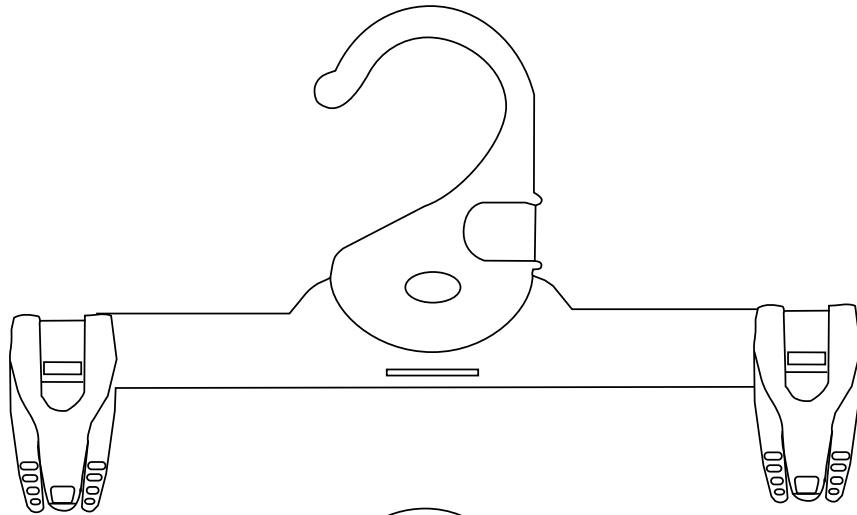

**FL57**  
**280mm**

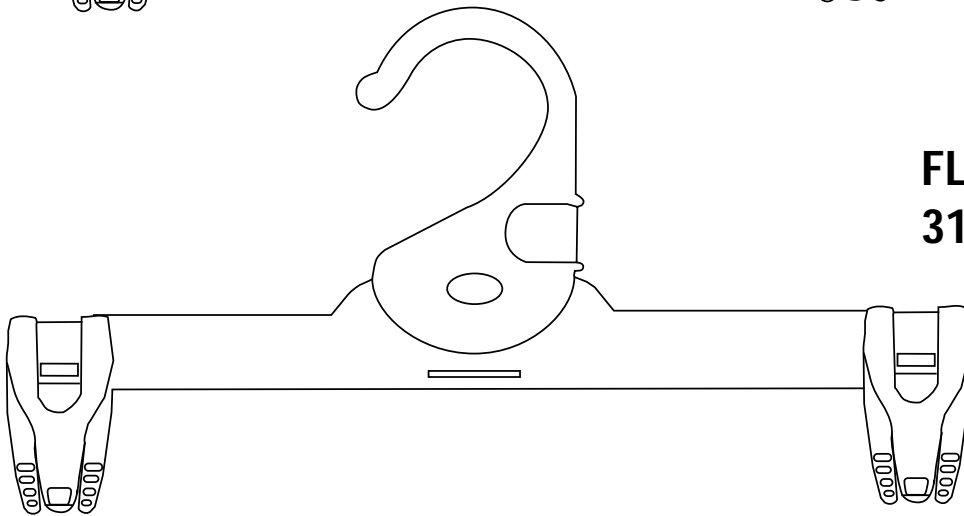

**FL58**  
**310mm**

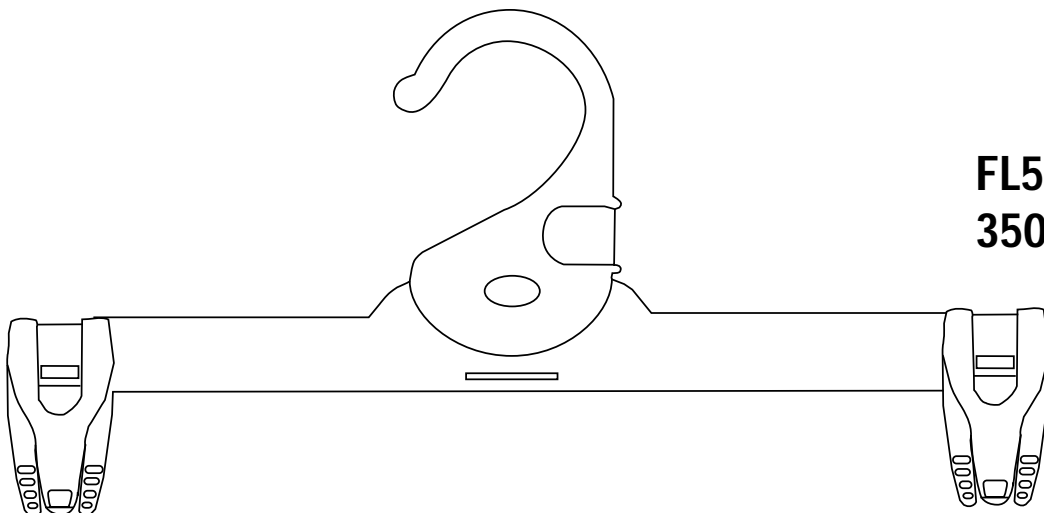

**FL59**  
**350mm**

C O D E

**BSL82**

**Category** • Adult

**Application** • Pants, Shorts and Skirts  
Fabrics - Velours, Satins, Corduroy etc..

**Adult  
Soft Lock  
Padded Hanger**

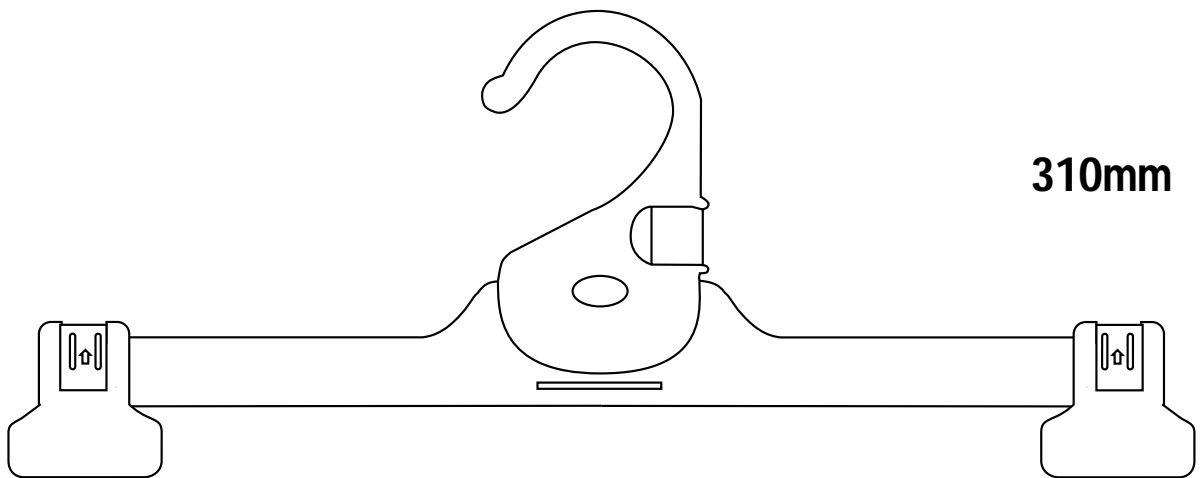

**310mm**

**Category • Adult**

**Application • Trousers**

C O D E

**BH81X**

**340mm  
Trousers Hanger**

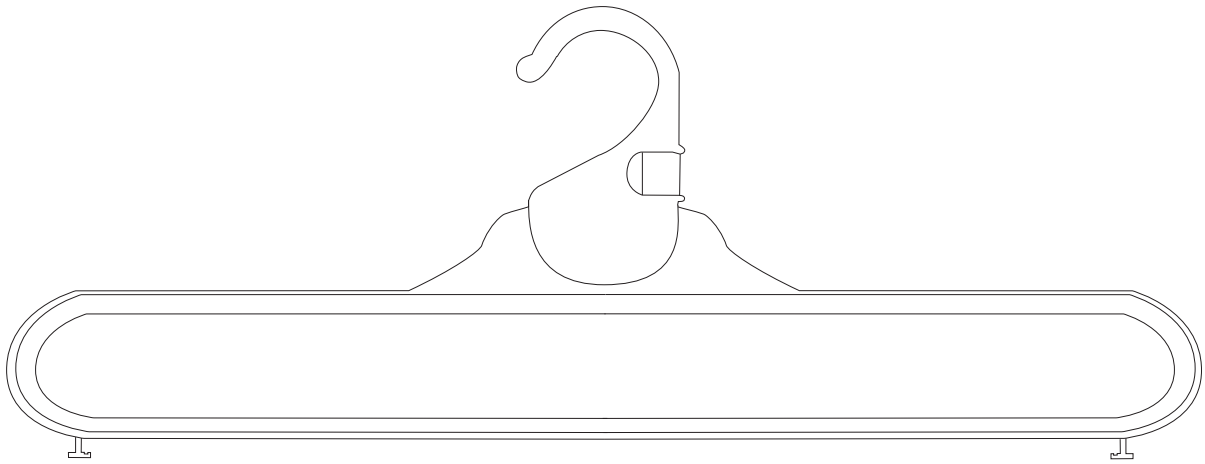

C O D E

FR78

FR79

FR80

Frame Hanger

Category • Infant and Toddlers

Application • 2 Piece sets

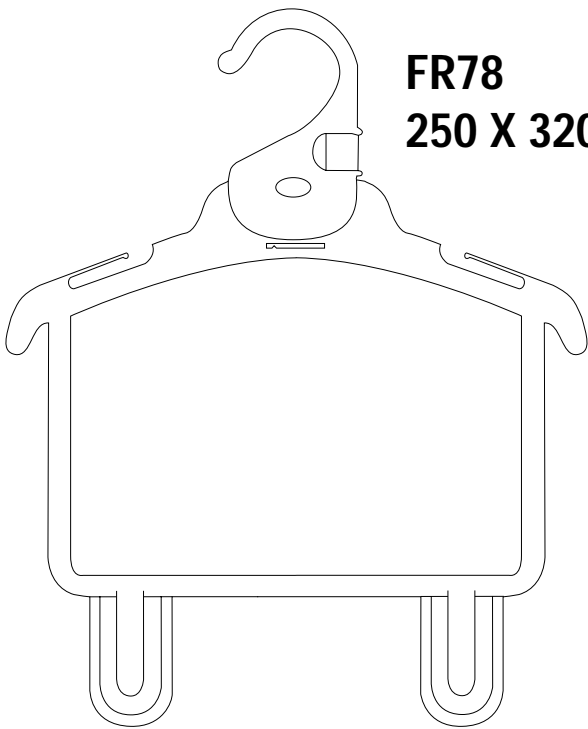

**FR78**  
**250 X 320mm**

**FR79**  
**250 X 350mm**

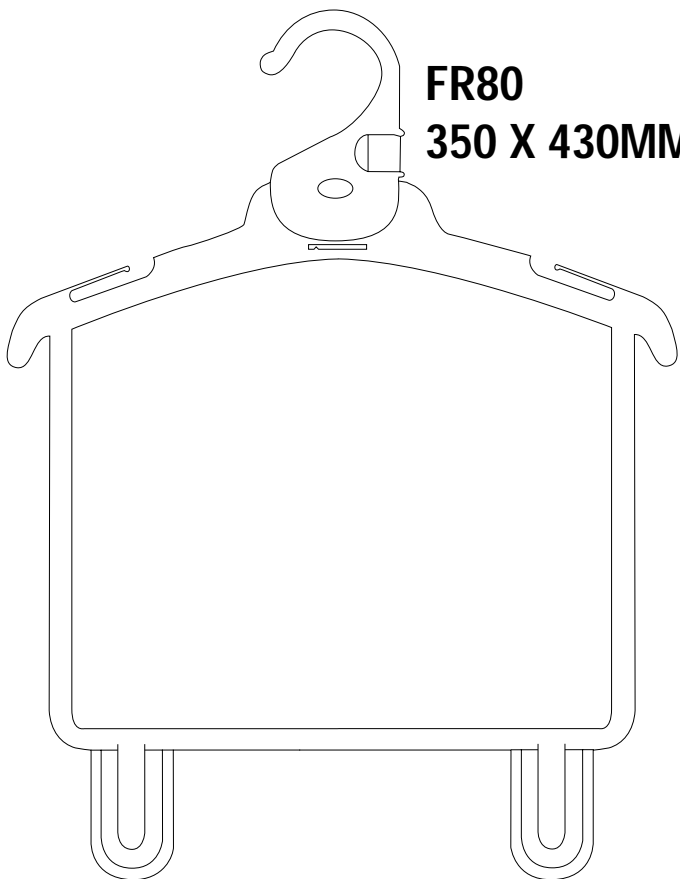
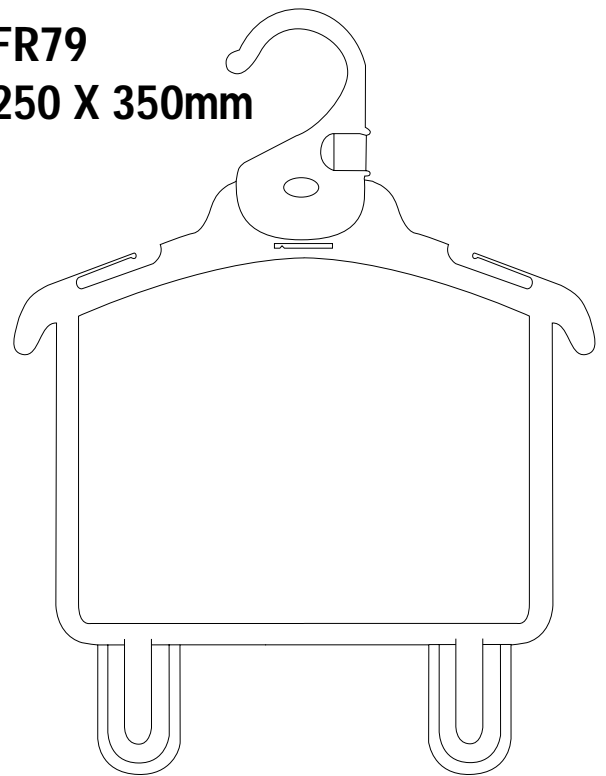

**FR80**  
**350 X 430MM**

**Category** • Infants, Toddlers

**Application** • Multi Sets

C O D E

**TH40DS**

**155mm x  
250mm**

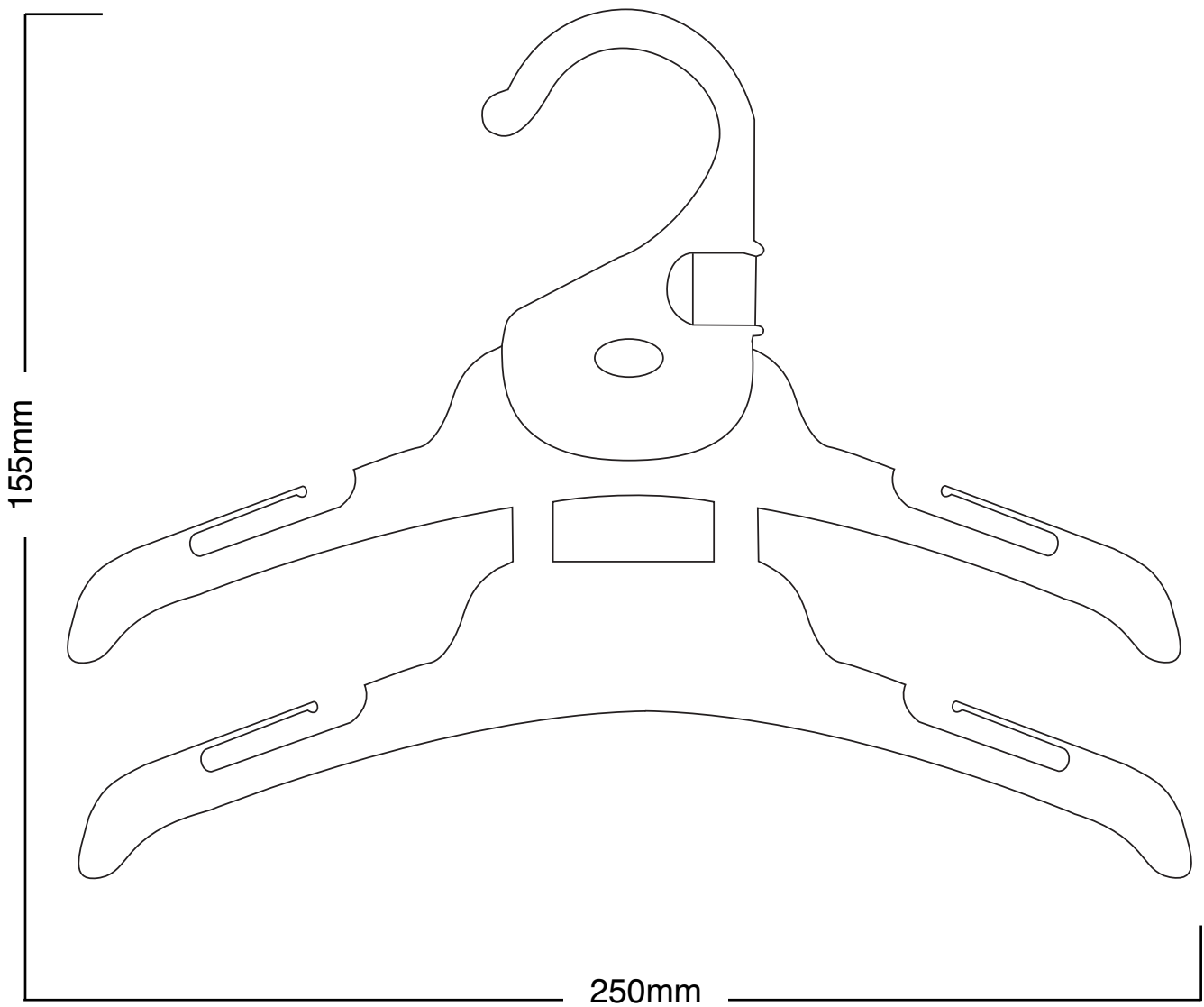

**Category** • Infants, Toddlers

**Application** • Multi Sets

C O D E  
**TH41DS**

**155mm x  
300mm**

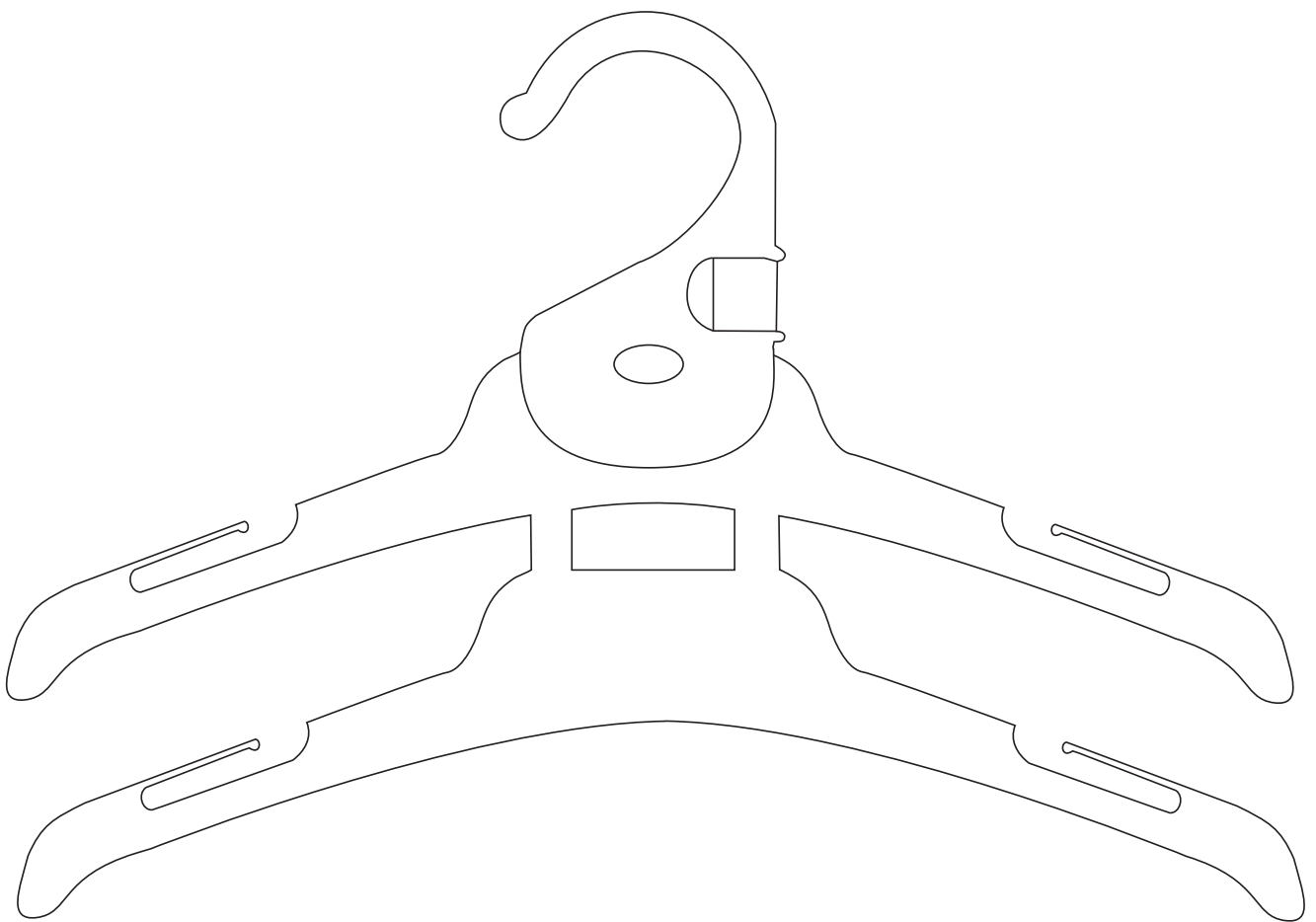

**Category** • Childrens

**Application** • Multi Sets

C O D E  
**TH42DS**

**155mm x  
350mm**

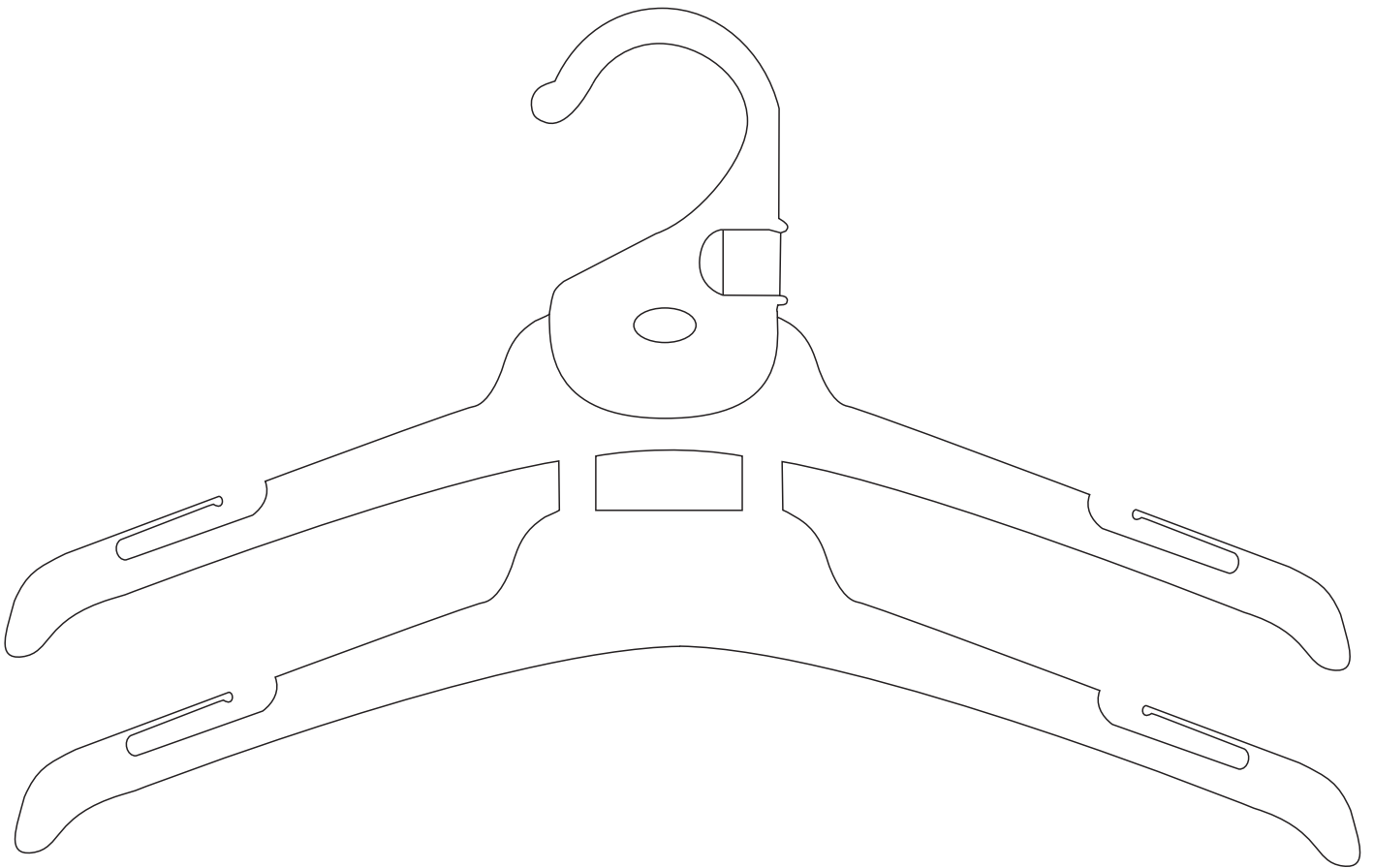

C O D E

TP89

**Category** • Infantswear

**Application** • Sleepsuits & Rompers

**Single prong**

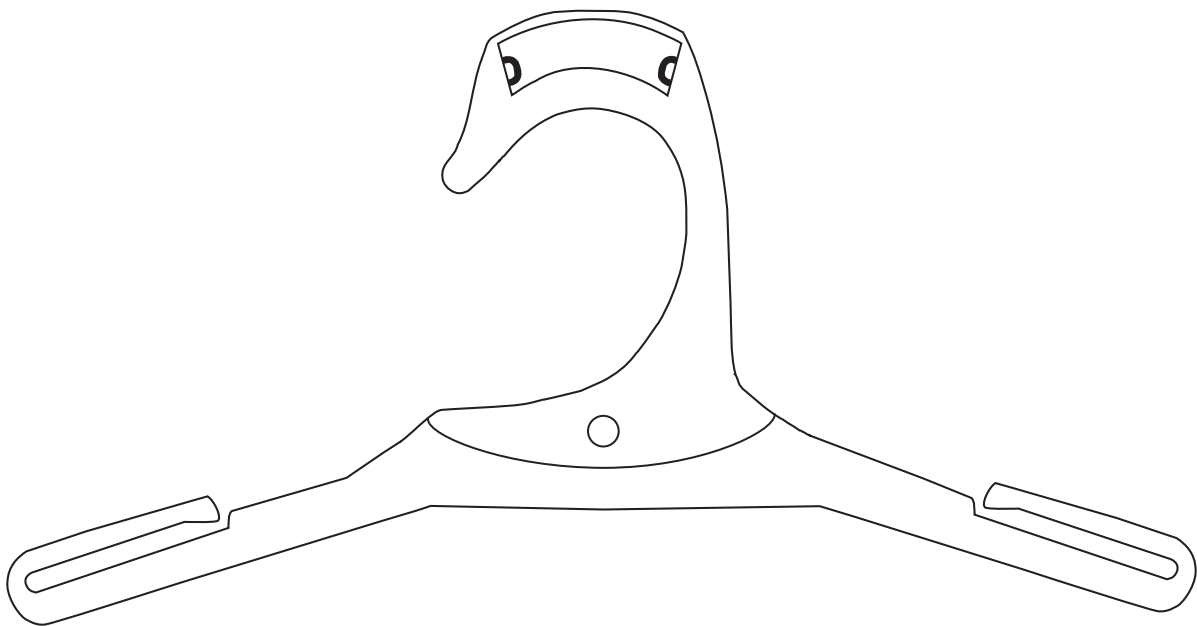

C O D E

TP90

TP91

Multi  
Garments

Category • Infantswear

Application • Sleepsuits, Rompers, 2 Piece Sets

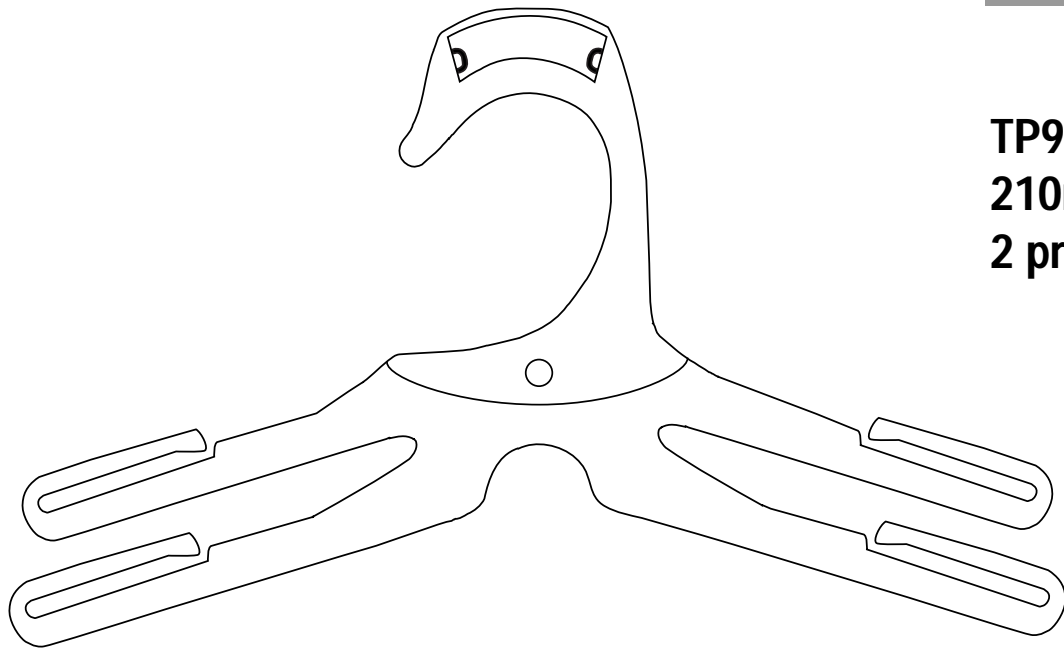

TP90  
210mm  
2 prong

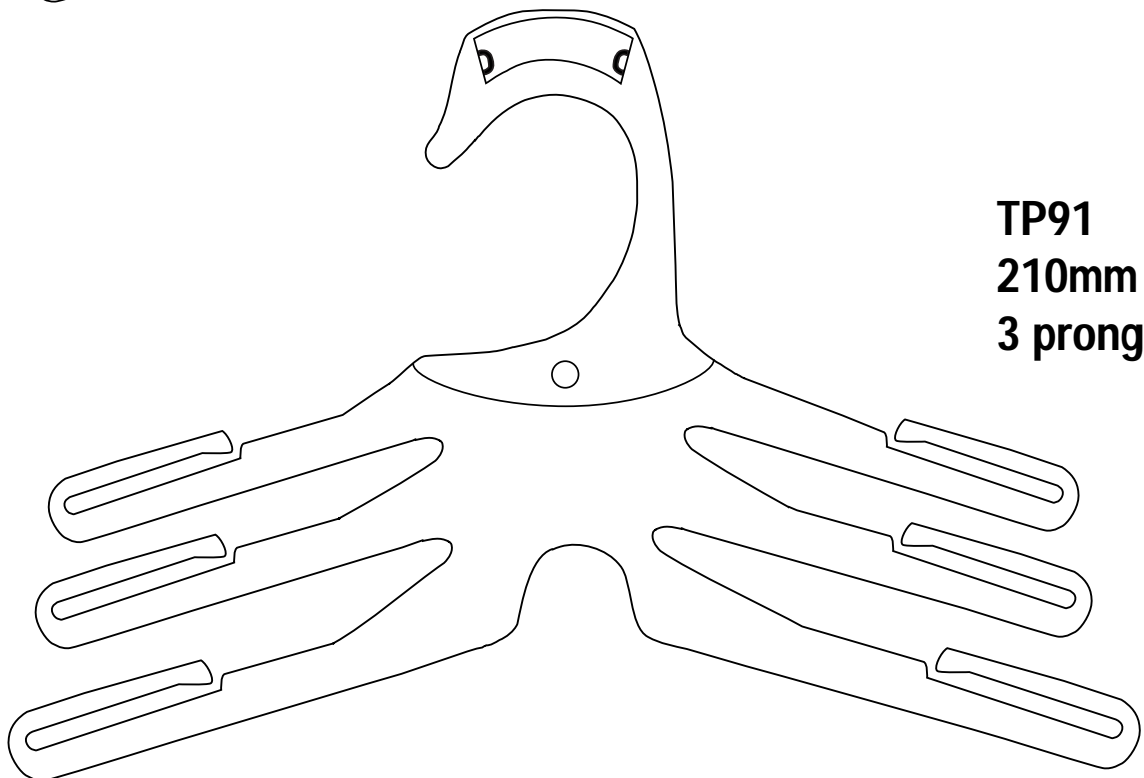

TP91  
210mm  
3 prong

C O D E

TP95

Multi  
Garments

**Category** • Infantswear

**Application** • Sleepsuits, Rompers, Sets and Tops

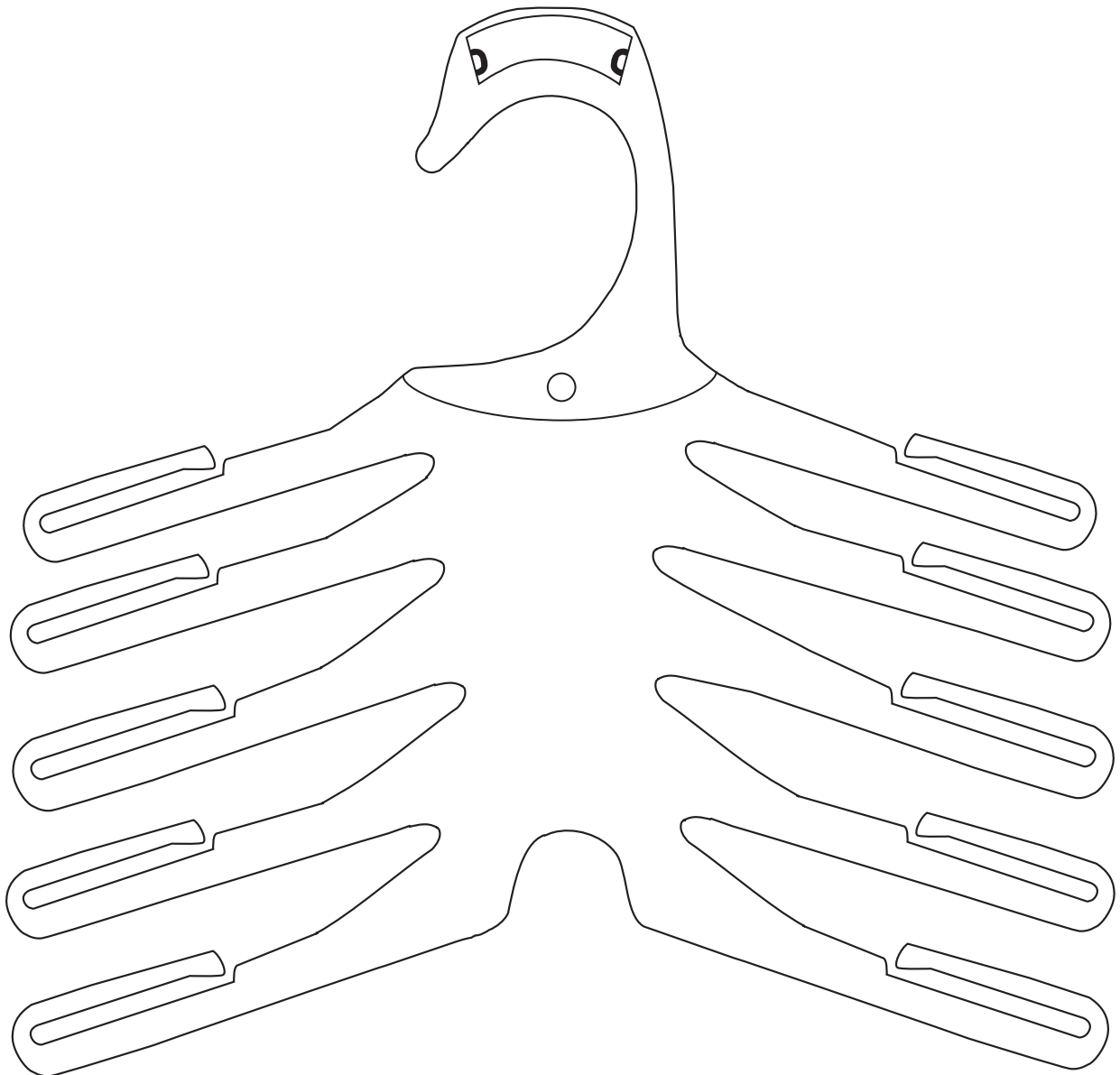

C O D E

AC16

Category • All

Application • All general purpose hangers  
for outerwear and sleepwear

Size Clips



actual size

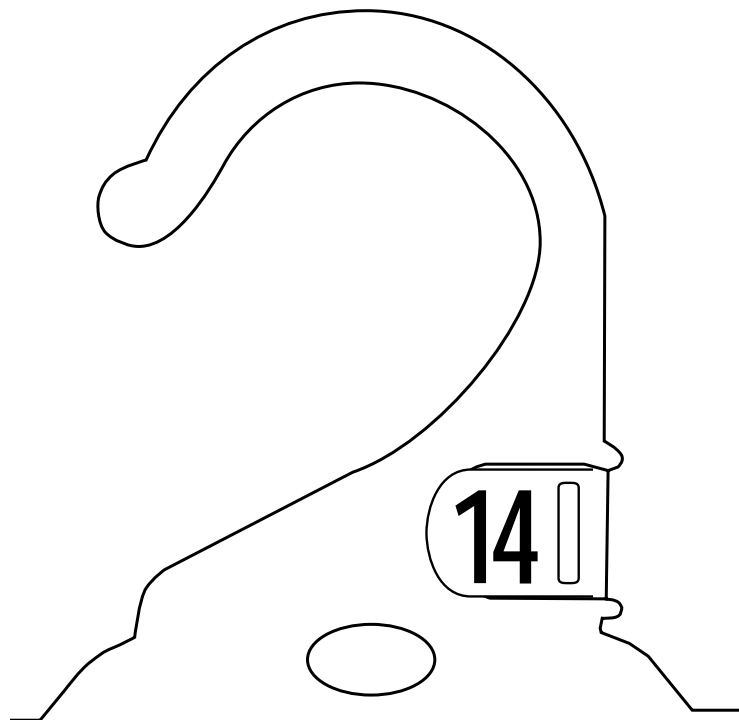

# TARGET AC16 SIZE CLIP CHART

## Outerwear Hangers Only

CHILDRENSWEAR		
SIZE	PMS	COLOUR
tiny baby	396	Lime
new baby	318	Turquoise
0-3mths	347	Dark Green
3-6mths	164	Orange
6-12mths	264	Lilac
12-18mths	185	Red
18-24mths	121	Yellow
000000	BLK	Black
00000	396	Lime
0000	318	Turquoise
000	347	Dark Green
00	164	Orange
0	264	Lilac
1	185	Red
2	121	Yellow
3	230	Pink
4	359	Pale Green
5	154	Tan Brown
6	264	Lilac
7	444	Grey
8	185	Red
9	230	Pink
10	279	Dark Blue
11	347	Dark Green
12	347	Dark Green
14	318	Turquoise
16	154	Tan Brown
2/3	230	Pink
3/4	359	Pale Green
4/6	264	Lilac
6/8	185	Red
8/10	279	Dark Blue
10/12	347	Dark Green
12/14	318	Turquoise
14/16	154	Tan Brown
1-3	230	Pink
S	347	Dark Green
M	185	Red
L	PB	Proc Blue

LADIESWEAR		
SIZE	PMS	COLOUR
4	318	Turquoise
6	506	Maroon
8	359	Pale Green
9	MAG	Magenta
10	154	Tan Brown
11	359	Pale Green
12	185	Red
13	155	Buff Yellow
14	279	Dark Blue
16	264	Lilac
18	121	Yellow
20	347	Dark Green
22	444	Grey
24	164	Orange
26	230	Pink
8/10	154	Tan Brown
10/12	185	Red
10/16	264	Lilac
12/14	279	Dark Blue
14/16	264	Lilac
16/18	121	Yellow
18/20	347	Dark Green
18/22	444	Grey
20/22	444	Grey
22/24	164	Orange
24/26	230	Pink
XXS	264	Lilac
XS	318	Turquoise
S	347	Dark Green
M	185	Red
L	PB	Proc Blue
XL	157	Brown
OSFA	WHT	White
8	WHT	White
10	WHT	White
12	WHT	White
14	WHT	White
16	WHT	White
18	WHT	White
20	WHT	White
8-10	WHT	White
12-14	WHT	White
16-18	WHT	White
20-22	WHT	White

MENSWEAR cont....		
SIZE	PMS	COLOUR
38	318	Turquoise
39	347	Dark Green
40	185	Red
41	PB	Proc Blue
42	157	Brown
43	375	Bright Green
44	121	Yellow
46	150	Light Orange
72	264	Lilac
77	318	Turquoise
82	347	Dark Green
87	185	Red
87S	185	Red
92	PB	Proc Blue
92S	PB	Proc Blue
97	157	Brown
97S	157	Brown
102	375	Bright Green
107	121	Yellow
112	154	Tan Brown
117	150	Light Orange
122	BLK	Black
127	444	Grey
132	MAG	Magenta
XS	318	Turquoise
S	347	Dark Green
M	185	Red
L	PB	Proc Blue
XL	157	Brown
XXL	375	Bright Green
2XL	375	Bright Green
3XL	121	Yellow
4XL	154	Tan Brown
5XL	150	Light Orange
6XL	BLK	Black
XL/2XL	375	Bright Green
3XL/4XL	154	Tan Brown
5XL/6XL	WHT	White
7XL/8XL	MAG	Magenta
OSFA	WHT	White

**Plain Unsized Black Clips  
No Sizing Required**

**For any new orders of Size Clips  
that are not on the current  
range a set fee of  
AUD\$250.00 will apply.**

**Category** • Adults

**Application** • Metal Hook Hangers

C O D E

**AC18**

**Size Clip**



# TARGET AC18 SIZE CLIP CHART

Outerwear Hangers Only

## ADULTS

SIZE	PMS	COLOUR
8	359	Pale Green
10	154	Tan Brown
12	185	Red
14	279	Dark Blue
16	264	Lilac
18	121	Yellow
20	347	Dark Green
22	444	Grey
24	164	Orange
26	230	Pink
12-14	279	Dark Blue
16-18	121	Yellow
20-22	444	Grey
24-26	230	Pink
XS	318	Turquoise
S	347	Dark Green
M	185	Red
L	PB	Proc Blue
XL	157	Brown
XXL	375	Bright Green

C O D E

LH34

LH35

LH76

Adult Brief  
Hanger

**Category** • Childrens & Adult

**Application** • Briefs and Bras  
(Black = Swimwear and Activewear)

LH35  
200mm

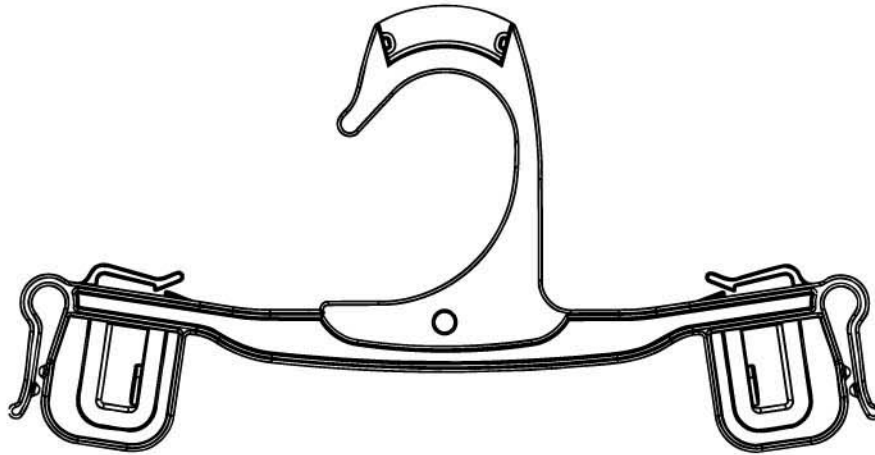

LH34  
250mm

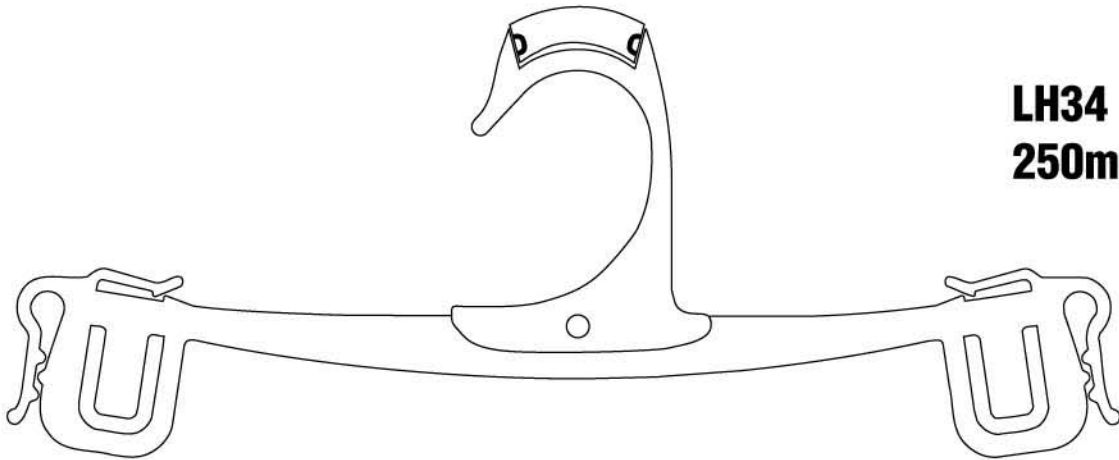

LH76  
310mm

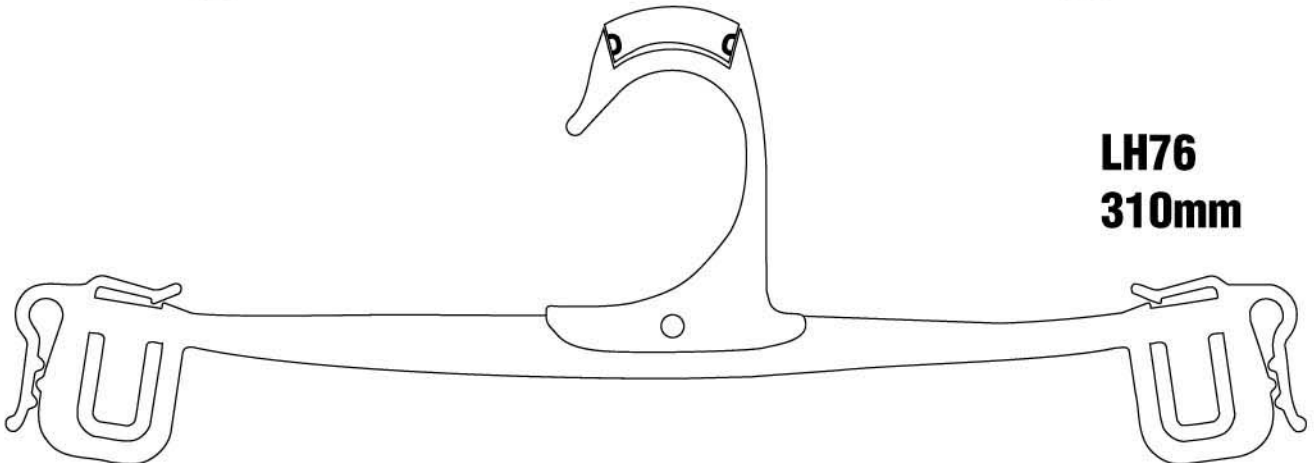

• LH35BL = BLACK

• LH34BL = BLACK  
• LH34CR = CRYSTAL

• LH76BL = BLACK  
• LH76CR = CRYSTAL

**Category** • Adults

**Application** • Briefs, Delicates

C O D E

**LH89CR**

**Adult Brief  
Hanger  
265mm**

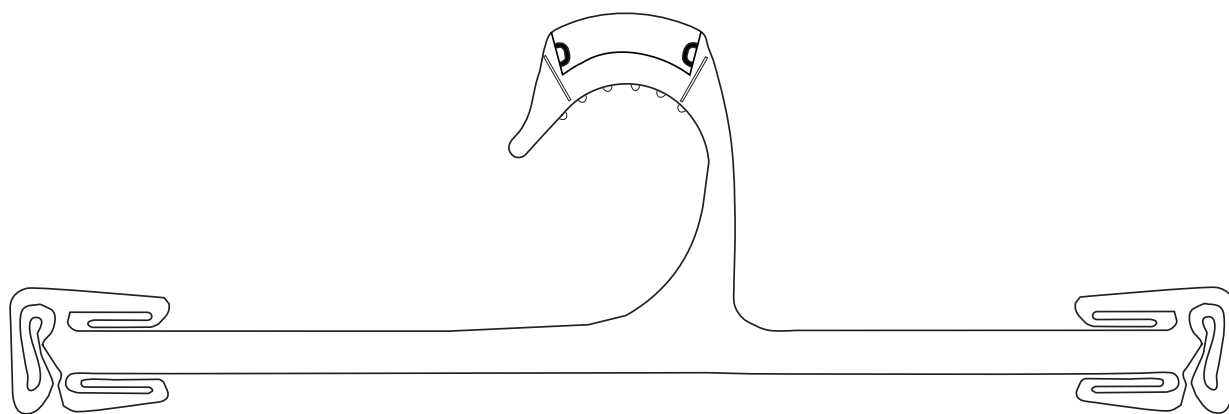

C O D E

LH75BL

LH85

Adults and  
Childrens  
Brief Hanger

**Category** • Children, Adult

**Application** • Briefs, Bras, Camisoles and Underwear Sets  
(Black = Swimwear and Activewear)

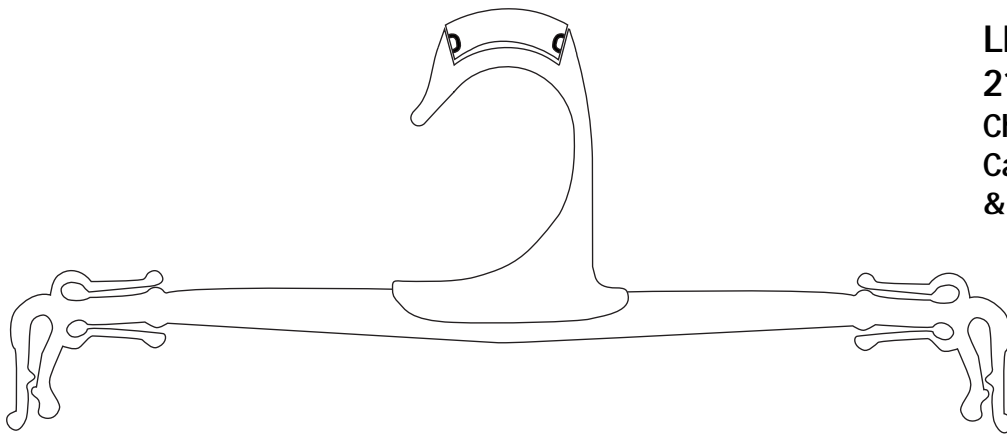

LH75BL  
210mm  
Childrens Brief,  
Camisole  
& Underwear Sets

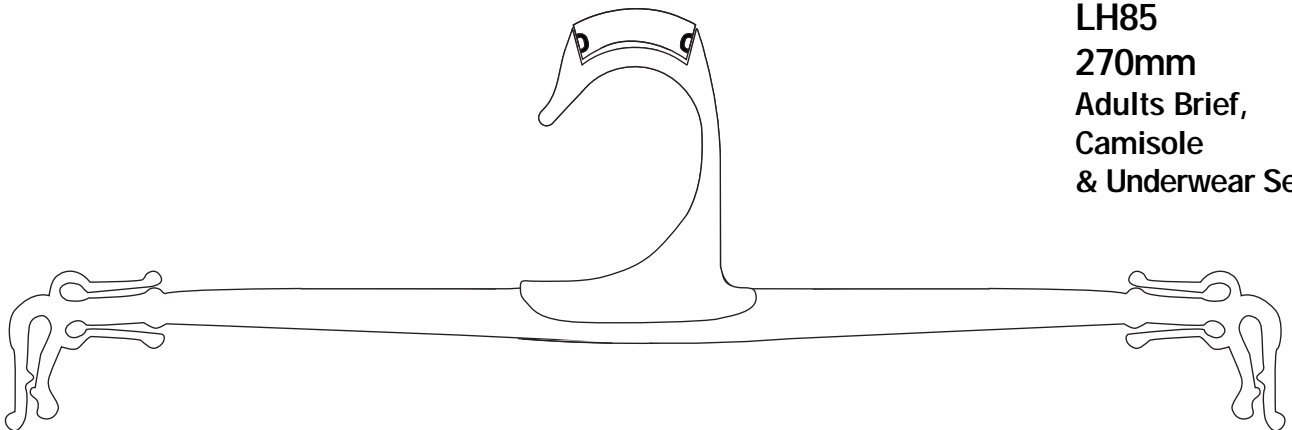

LH85  
270mm  
Adults Brief,  
Camisole  
& Underwear Sets

- LH75BL = BLACK
- LH85BL = BLACK
- LH85CR = CRYSTAL

C O D E

**Category** • Adults

**Application** • Lingerie 2 piece garments

**LH88**

**Adults**  
**2 piece Hanger**  
**225mm**

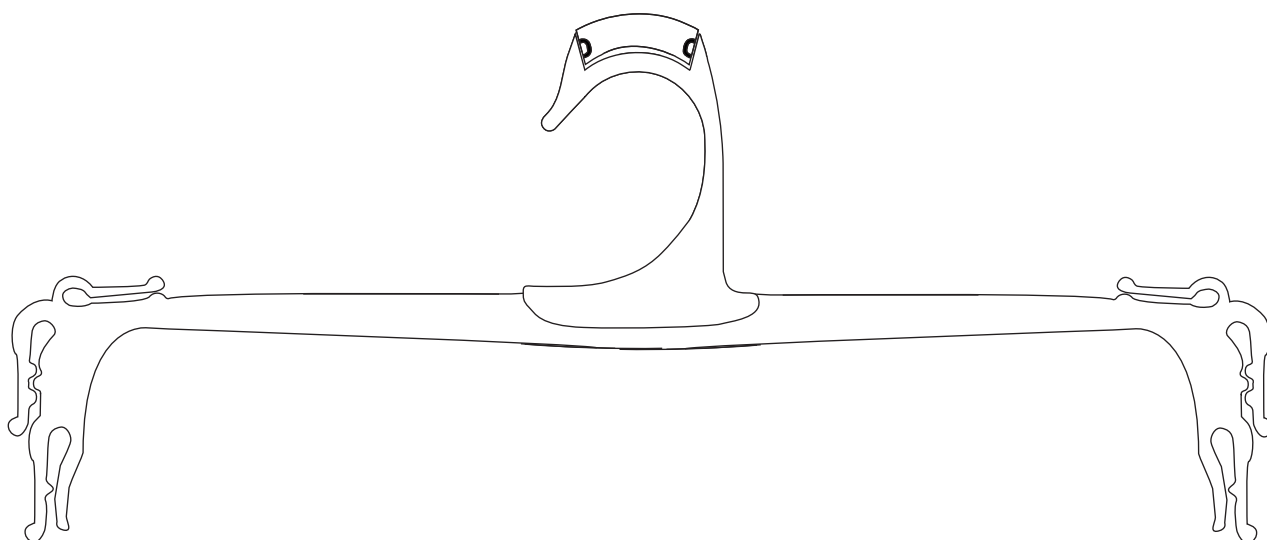

- LH88BL = BLACK
- LH88CR = CRYSTAL

Category • Womens

Application • Bra's

C O D E

**BR32CR**

**BR33CR**

BraHanger

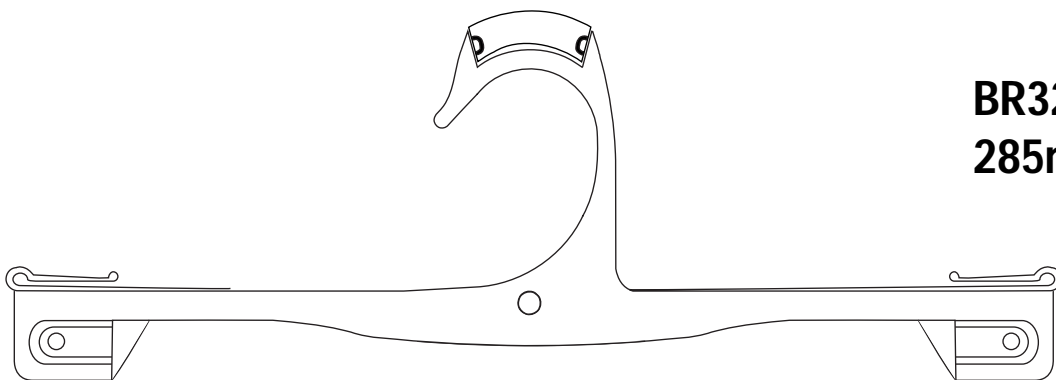

**BR32CR**  
**285mm**

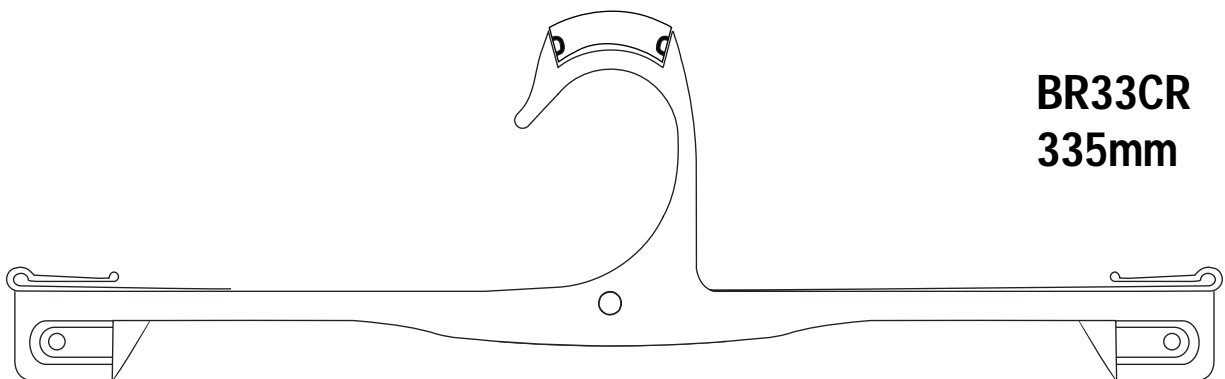

**BR33CR**  
**335mm**

- BR32CR = CRYSTAL
- BR33CR = CRYSTAL

**Category** • Adults

**Application** • Lingerie 3 piece garments

C O D E

**LH93**

**Adults**  
**2 piece Hanger**  
**225mm**

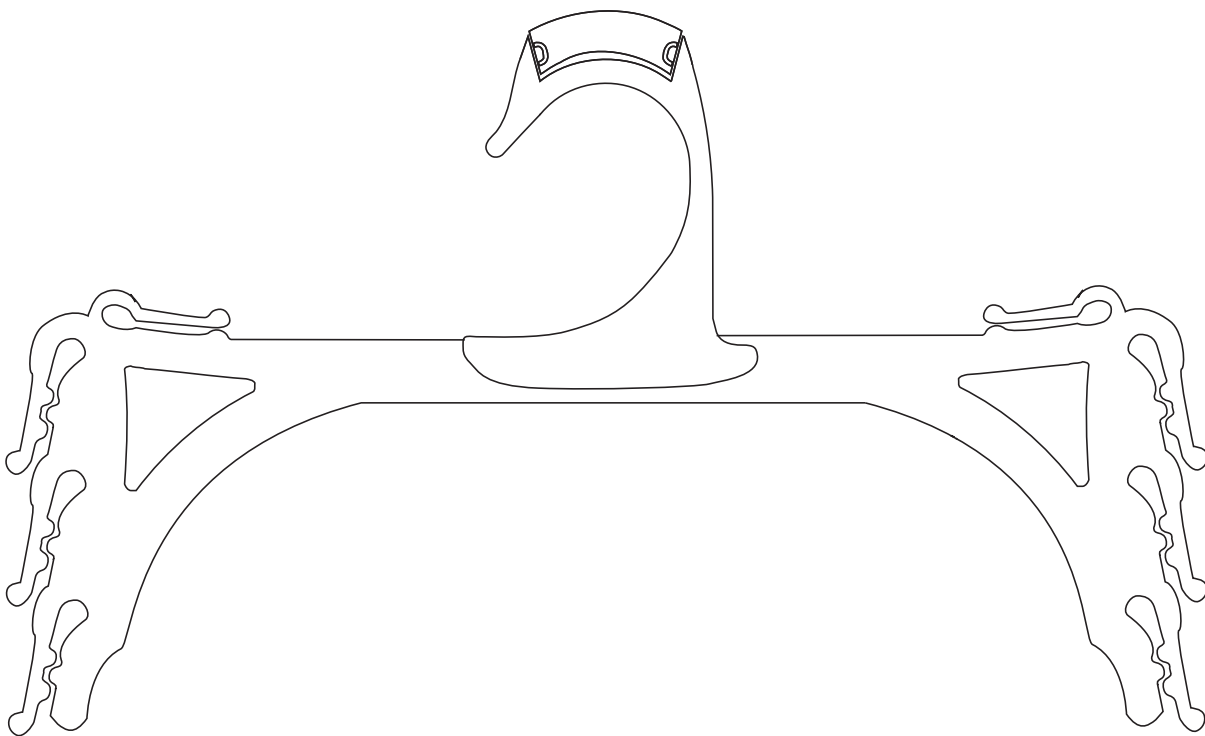

- LH93BL = BLACK
- LH93CR = CRYSTAL

C O D E

AC22

**Category** • All

**Application** • Colour coded size inserts  
for underwear and lingerie hangers

Lingerie  
Sizing Insert

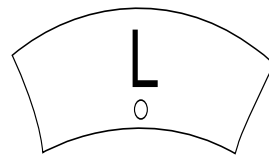

actual size

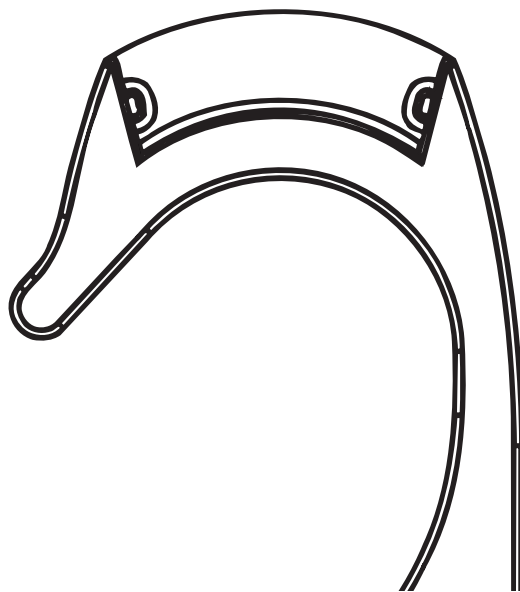

# TARGET AC22 SIZE TAB CHART

Lingerie Hangers Only

## LADIESWEAR

SIZE	PMS	COLOUR
8	359	Pale Green
10	154	Tan Brown
12	185	Red
14	279	Dark Blue
16	264	Lilac
18	121	Yellow
20	347	Dark Green
22	444	Grey
24	164	Orange
26	230	Pink
8/10	154	Tan Brown
10/12	185	Red
12/14	279	Dark Blue
14/16	264	Lilac
16/18	121	Yellow
18/20	347	Dark Green
20/22	444	Grey
22/24	164	Orange
24/26	230	Pink
8A	359	Pale Green
8AA	359	Pale Green
8AAA	359	Pale Green
10AA	154	Tan Brown
10A	154	Tan Brown
10B	154	Tan Brown
10C	154	Tan Brown
10D	154	Tan Brown
10DD	154	Tan Brown
10E	154	Tan Brown
10F	154	Tan Brown
10G	154	Tan Brown
12AA	185	Red
12A	185	Red
12B	185	Red
12C	185	Red
12D	185	Red
12DD	185	Red
12E	185	Red
12F	185	Red
12G	185	Red
14A	279	Dark Blue
14B	279	Dark Blue
14C	279	Dark Blue
14D	279	Dark Blue
14DD	279	Dark Blue
14E	279	Dark Blue
14F	279	Dark Blue
14G	279	Dark Blue

## LADIESWEAR cont....

SIZE	PMS	COLOUR
16A	264	Lilac
16B	264	Lilac
16C	264	Lilac
16D	264	Lilac
16DD	264	Lilac
16E	264	Lilac
16F	264	Lilac
16G	264	Lilac
18B	121	Yellow
18C	121	Yellow
18D	121	Yellow
18DD	121	Yellow
18E	121	Yellow
18F	121	Yellow
18G	121	Yellow
20B	347	Dark Green
20C	347	Dark Green
20D	347	Dark Green
20DD	347	Dark Green
20E	347	Dark Green
20F	347	Dark Green
20G	347	Dark Green
22B	444	Grey
22C	444	Grey
22D	444	Grey
22DD	444	Grey
22F	444	Grey
22G	444	Grey
24B	164	Orange
24C	164	Orange
24D	164	Orange
24DD	164	Orange
24E	164	Orange
24F	164	Orange
24G	164	Orange
26C	230	Pink

## CHILDRENSWEAR

SIZE	PMS	COLOUR
tiny baby	396	Pale Green
new baby	318	Turquoise
0-3mths	347	Dark Green
3-6mths	164	Orange
6-12mths	264	Lilac
12-18mths	185	Red
18-24mths	121	Yellow
00000	396	Pale Green
0000	318	Turquoise
000	347	Dark Green
00	164	Orange
0	264	Lilac
1	185	Red
2	121	Yellow
3	230	Pink
4	359	Pale Green
5	154	Tan Brown
6	264	Lilac
7	444	Grey
8	185	Red
9	230	Pink
10	279	Dark Blue
12	347	Dark Green
14	318	Turquoise
16	154	Tan Brown
2/3	230	Pink
3/4	359	Pale Green
4/6	264	Lilac
6/8	185	Red
8/10	279	Dark Blue
10/12	347	Dark Green
12/14	318	Turquoise
14/16	154	Tan Brown

## MENSWEAR

SIZE	PMS	COLOUR
75/80	347	Dark Green
85/90	PB	Proc Blue
95/100	375	Bright Green
105/110	154	Tan Brown
125/130	MAG	Magenta
135/140	359	Pale Green
S	347	Dark Green
M	185	Red
L	PB	Proc Blue
XL	157	Brown
XXL	375	Bright Green
3XL	121	Yellow

Category • All

Application • Thongs

C O D E

FW24

Thong Hanger  
115mm

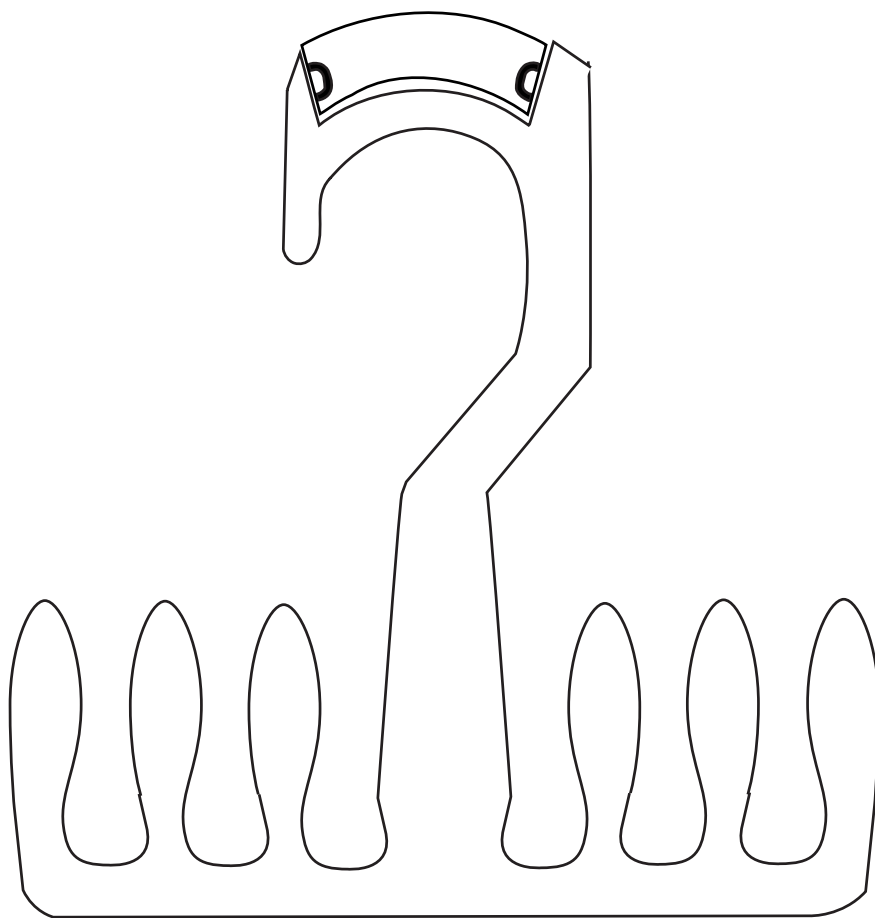

**Category** • Children, Adult

**Application** • Casual, Canvas and Court Shoes

C O D E

**FW23**

**FW22**

**FW75**

**Childrens  
U End Hanger**

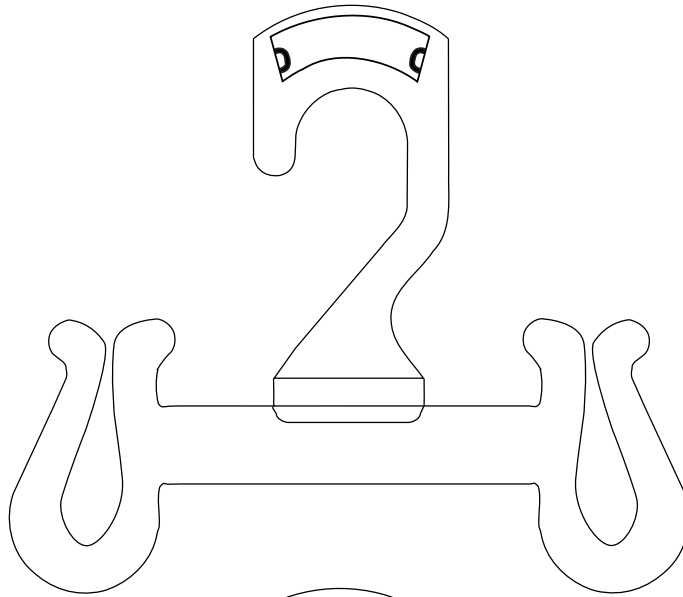

**FW23  
70mm**

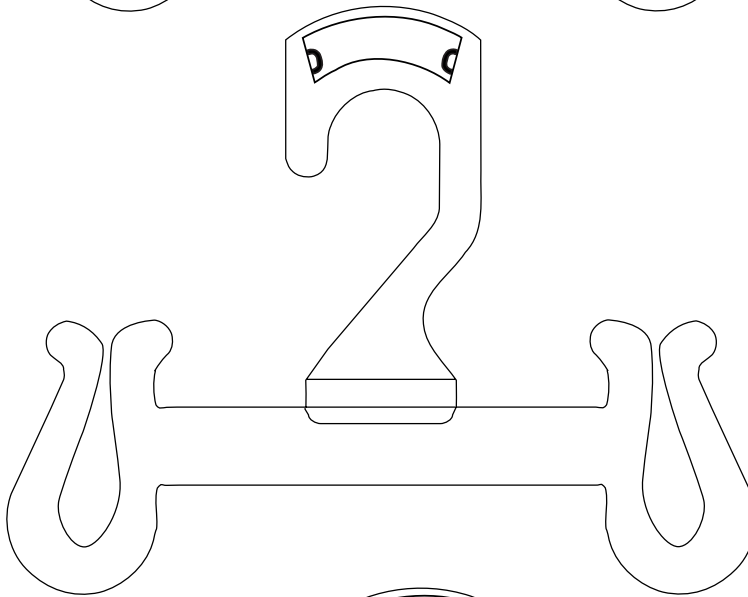

**FW22  
90mm**

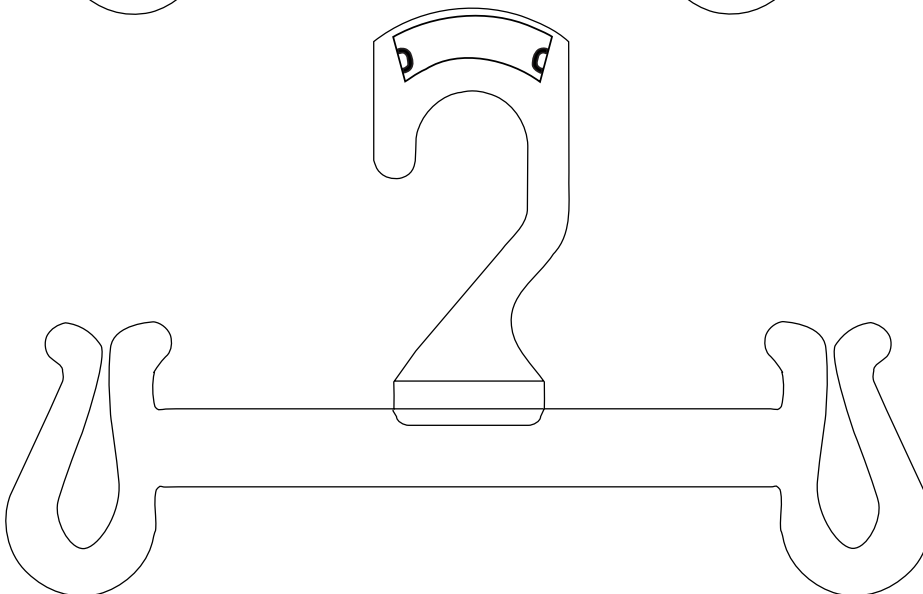

**FW75  
120mm**



**Category** • Mens

**Application** • Larger shoes

C O D E

**FW92**

**Men's  
Multi Purpose  
Shoe Hanger  
280mm**

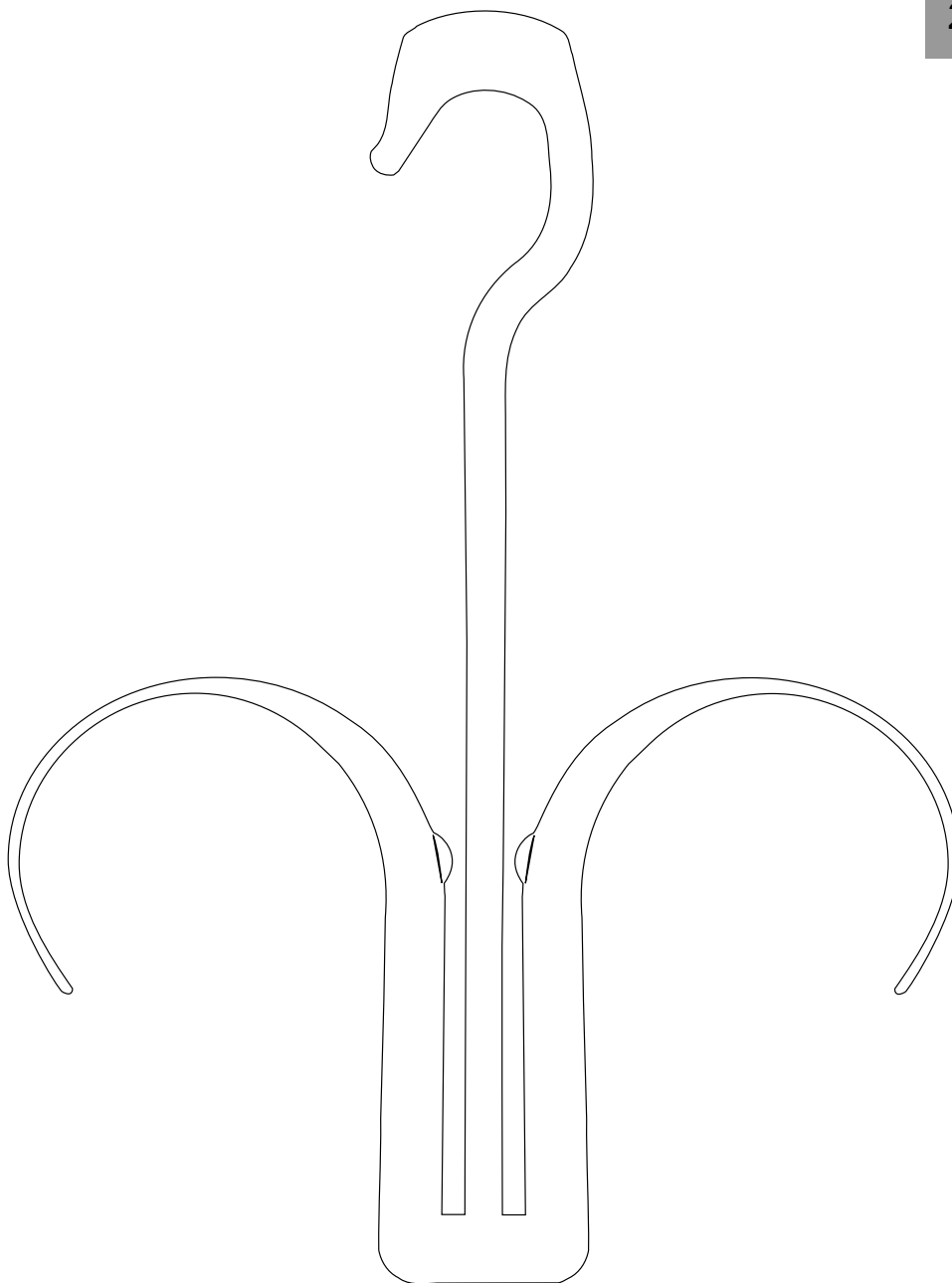

**Category • All**

**Application • Boots**

C O D E

**FW78**  
**FW79N**

**Boot Hanger**  
**180mm**

**FW78**  
**180mm**

**\*Not available**  
**in Australia**

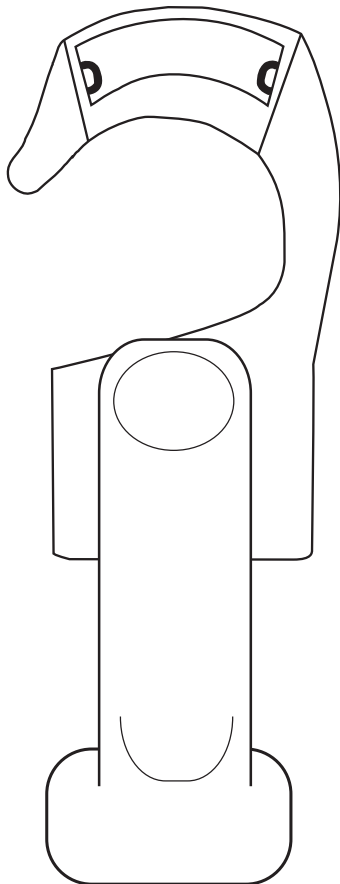
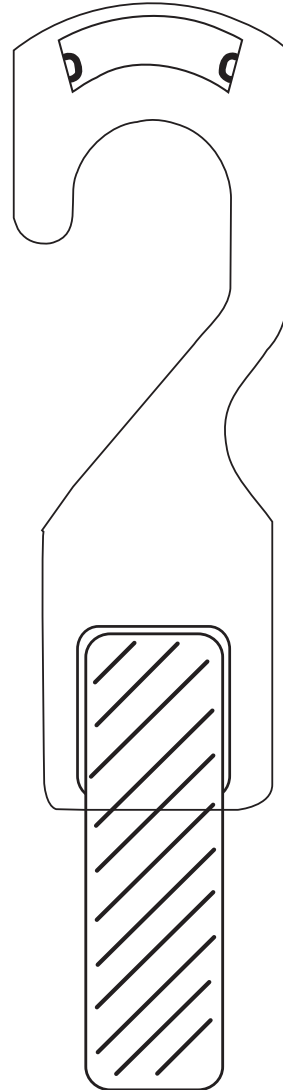

**FW79N**  
**130mm**

Category • All

Application • Colour coded size inserts for footwear

Sizing Insert  
for Footwear

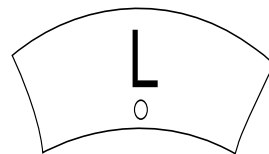

actual size

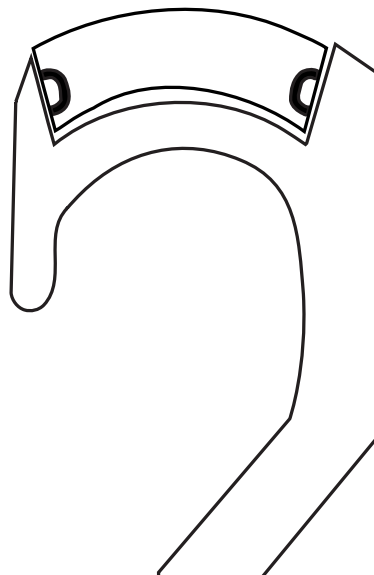

# COLES AC21 SIZE TAB CHART

## FOR FOOTWEAR HANGERS

GENERAL		
SIZE	PMS	COLOUR
1	185	Red
2	154	Tan Brown
3	264	Lilac
4	359	Pale Green
5	230	Pink
6	157	Brown
7	444	Grey
8	164	Orange
9	318	Turquoise
10	PB	Proc Blue
11	347	Dark Green
12	279	Dark Blue
13	121	Yellow
1/2	185	Red
2/3	154	Tan Brown
3/4	264	Lilac
4/5	359	Pale Green
5/6	230	Pink
6/7	157	Brown
7/8	444	Grey
8/9	164	Orange
9/10	318	Turquoise
10/11	PB	Proc Blue
11/12	347	Dark Green
12/13	279	Dark Blue
13/1	121	Yellow
S	347	Dark Green
M	185	Red
L	PB	Proc Blue
XL	157	Brown

Category • All

Application • Scarves, fine fabrics and wraps

C O D E

SC27

SC28

Scarf Hanger

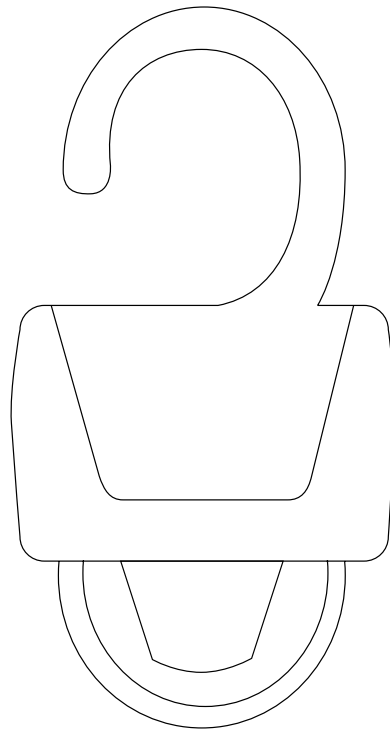

SC27  
35mm

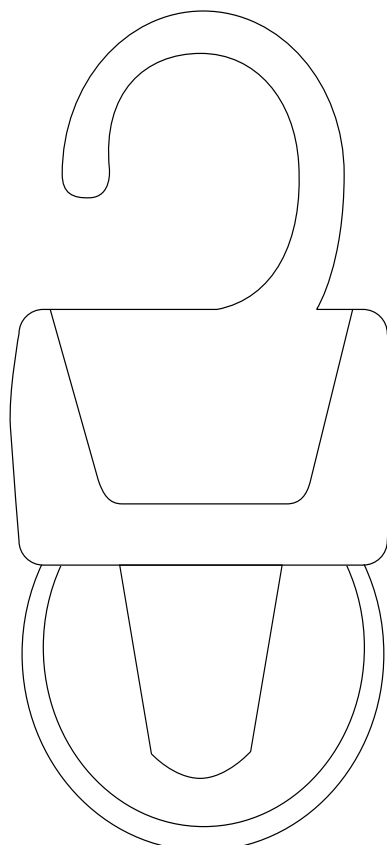

SC28  
50mm

C O D E

SC29

SC71

Shawl Hanger

Category • Adult

Application • Shawls, Wraps and Pashminas

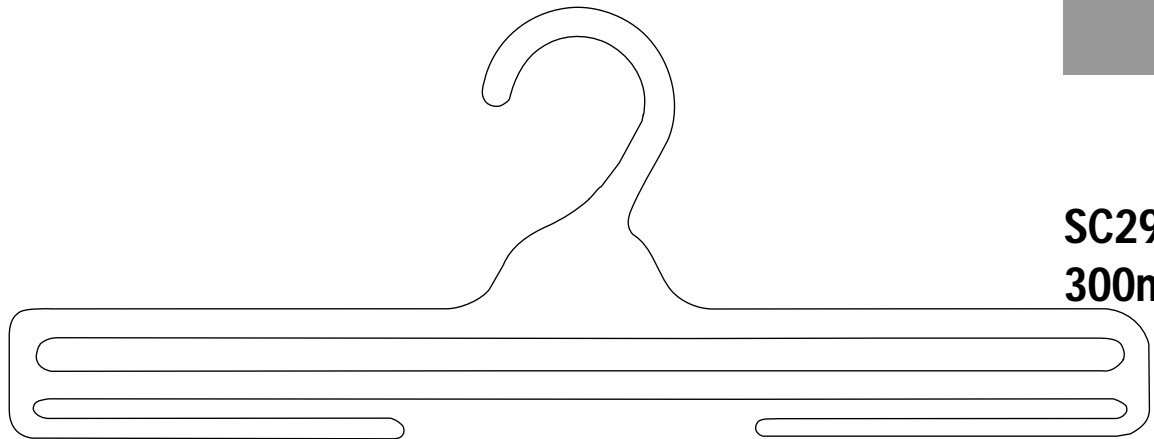

SC29  
300mm

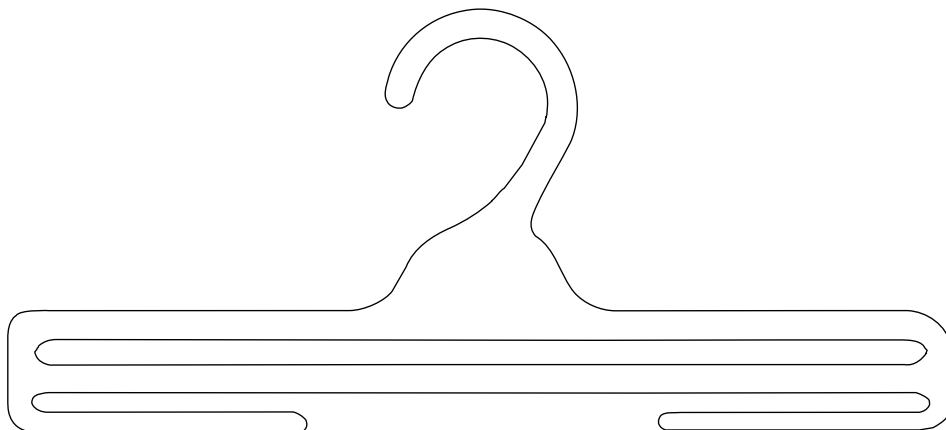

SC71  
225mm

Category • Childrens and Adult

Application • Hats, Gloves  
& Fashion Accessories

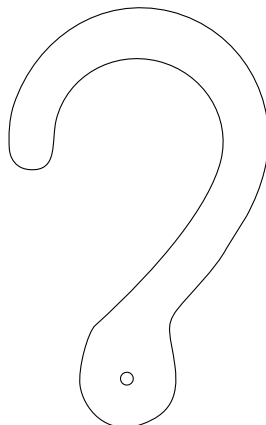

AC30  
Gun Hook

C O D E

**Category** • Adult

**Application** • Shawls, Wraps and Pashminas

SC70

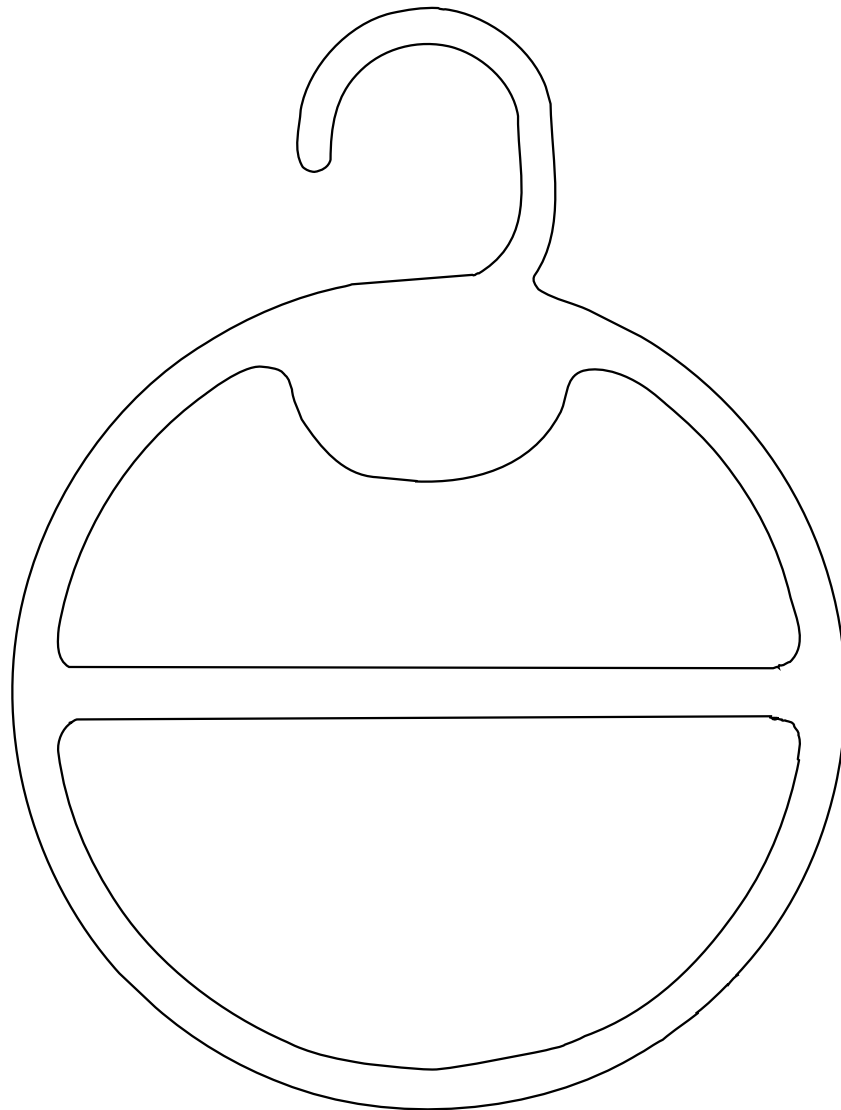

Category • All

Application • Totally interchangeable for all top and bottom hangers

Hook and Loop

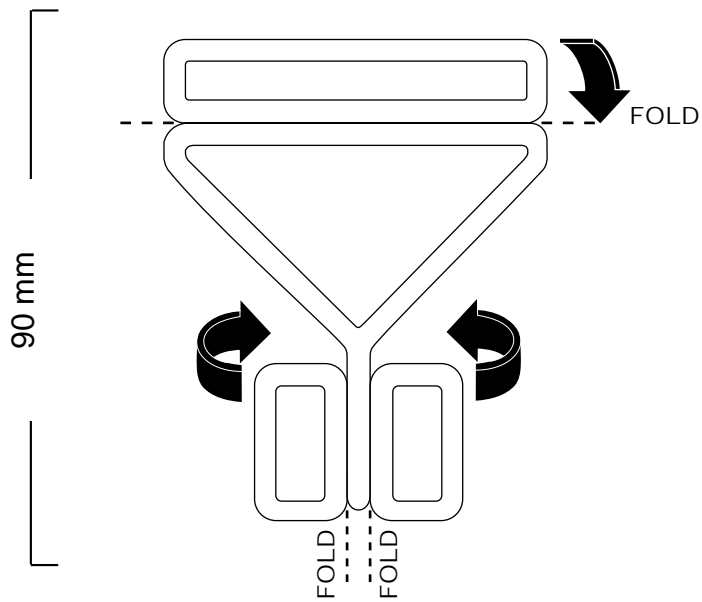

### STEP 1

Fold clip at positions indicated

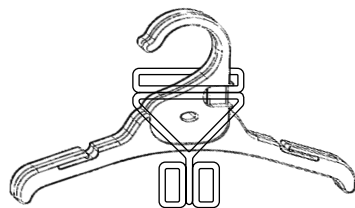

### STEP 2

Place clip over tops hanger

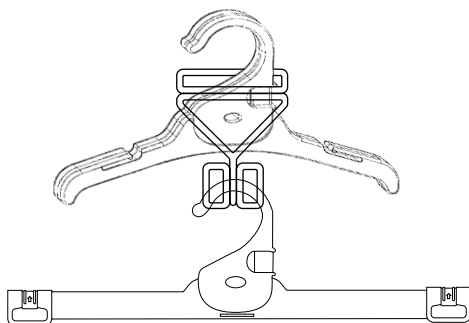

### STEP 3

Place bottoms hanger through both sections of lower clip

AC66

AC69

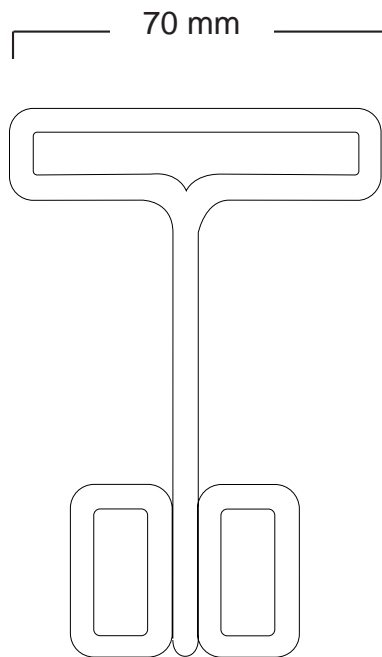
Hook and  
Loop**Category** • All**Application** • Totally interchangeable for all  
top and bottom hangers**AC69**  
**152mm****AC66**  
**250mm****STEP 1**

Place clip over tops hanger

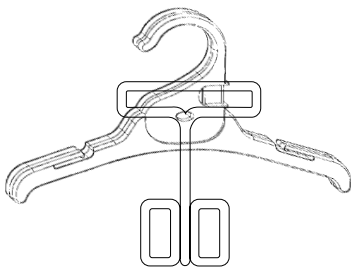
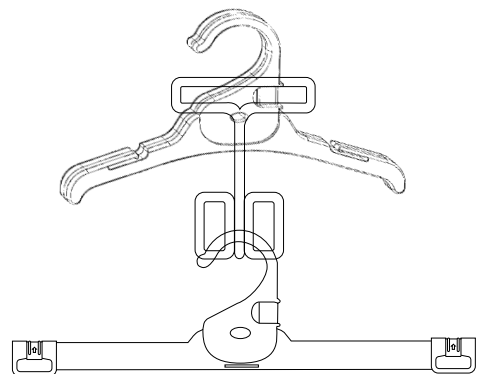
**STEP 2**Place bottoms hanger through both  
sections of lower clip

C O D E

**Category** • Adults

**Application** • Tops, Shirts, Dresses and Knitwear

**44H52**

**Premium Top  
Hanger  
420mm**

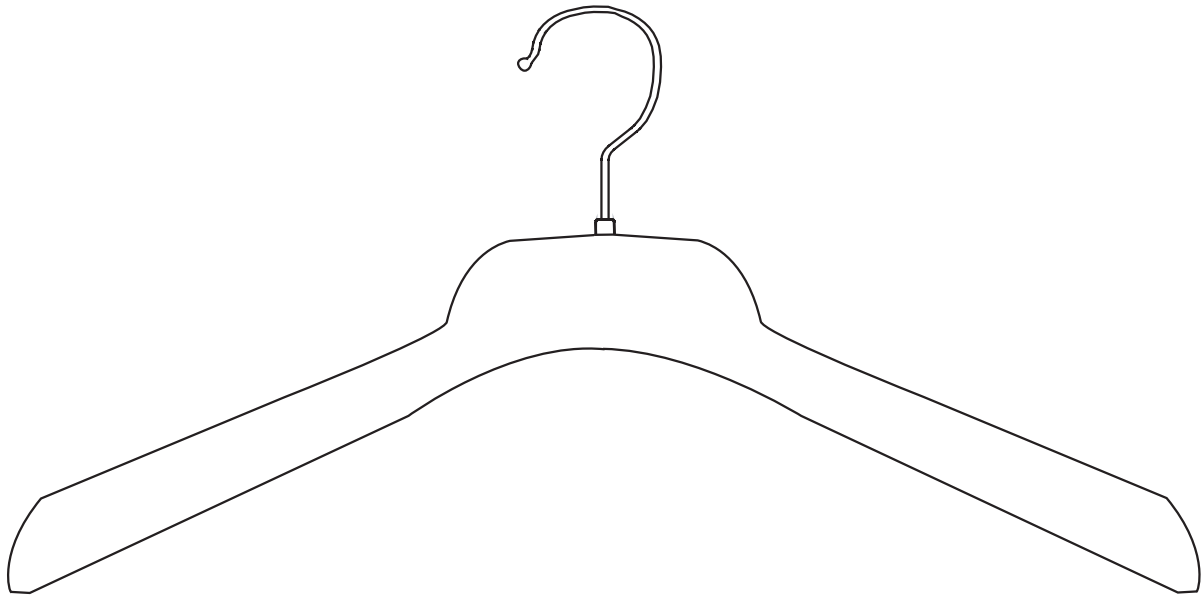

**Category** • Adults

**Application** • Tops, Shirts, Dresses & Knitwear

C O D E

**44H53**

**Premium Top  
Hanger  
420mm**

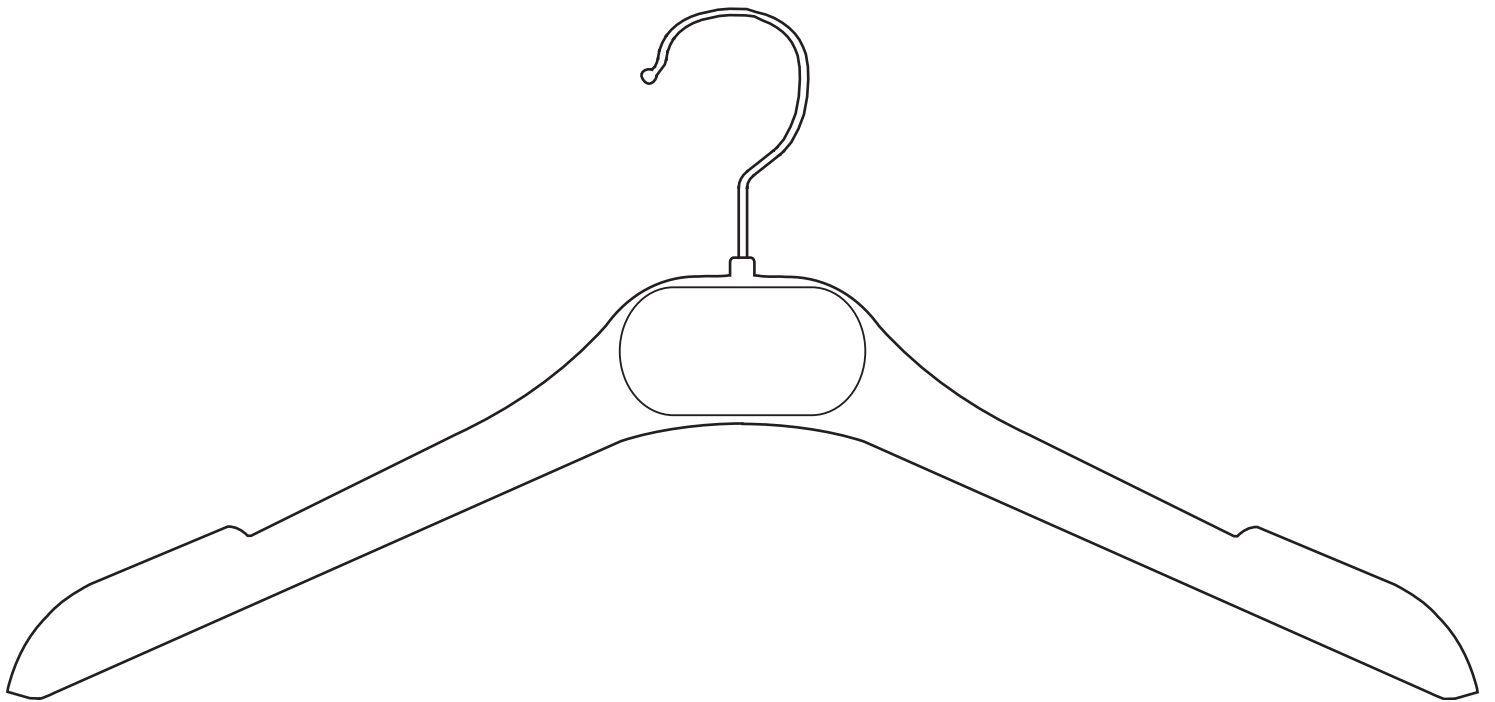

C O D E

**4455**

Premium  
Top Hanger  
410mm

**Category** • Adults

**Application** • Tops, Shirts, Dresses and Knitwear

410mm

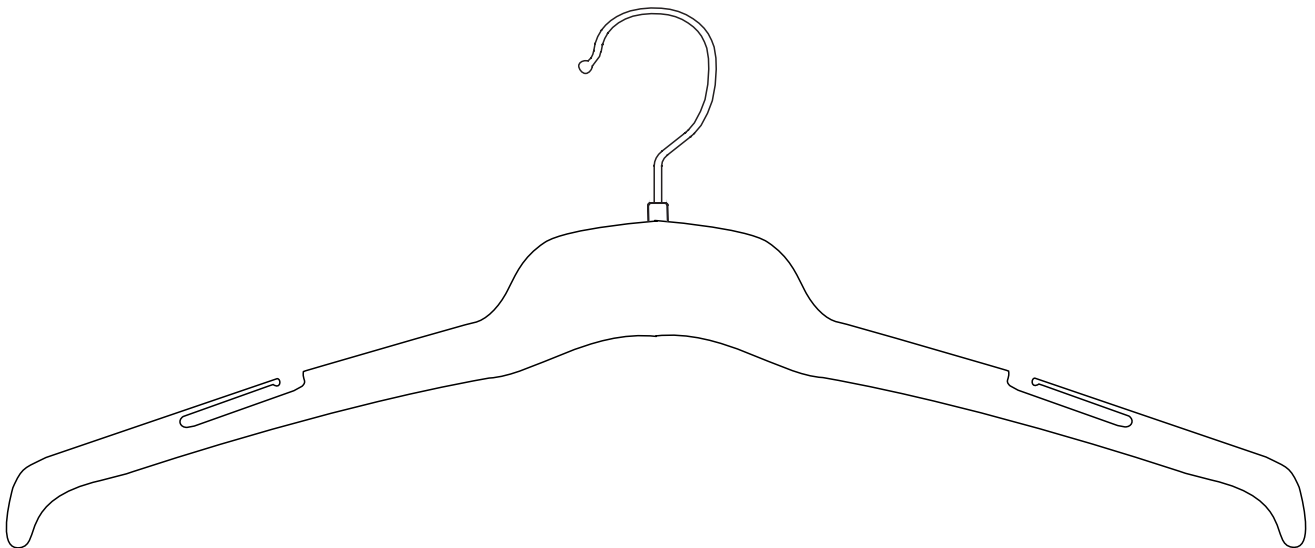

**Category** • Adult

**Application** • Tops, Shirts, Dresses and Knitwear

C O D E

4456

Premium  
Top Hanger  
460mm

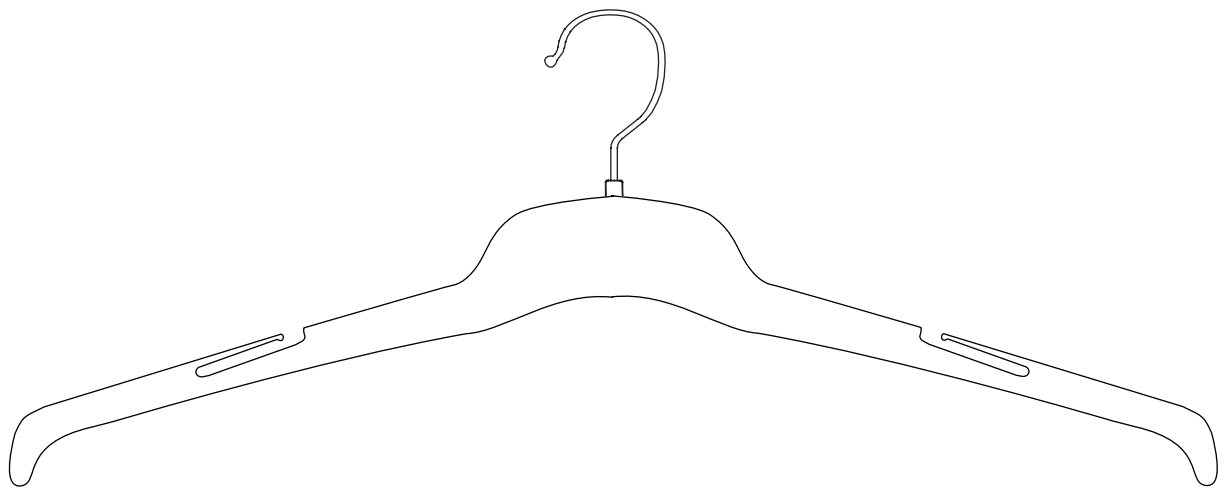

C O D E

4473

Premium Soft  
Lock Clip  
Hanger  
310mm

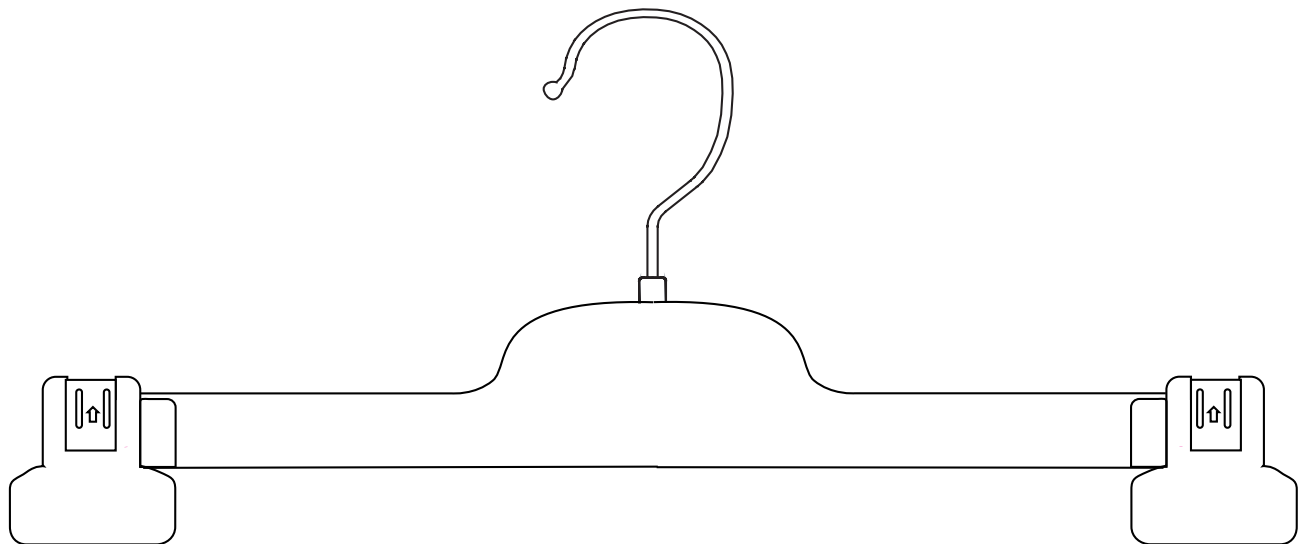

**AUSTRALIA****MELBOURNE**

214 Blackshaws Road  
Altona North Vic, 3025  
Australia.

Ph: 613 9393 3737  
Fax: 613 9393 3778

Email: [hangers@ticgroup.com.au](mailto:hangers@ticgroup.com.au)

**SYDNEY**

Unit 3, 79 Williamson Road  
Ingleburn, 2565, NSW  
Australia

Ph: 612 9618 5133  
Fax: 612 9618 5733

Email: [hangers.syd@ticgroup.com.au](mailto:hangers.syd@ticgroup.com.au)

**ASIA****HONG KONG**

Unit 3,5,6 and 7, 29/F Saxon Tower,  
7 Cheung Shun Street,  
Lai Chi Kok, Kowloon Hong Kong.

Ph: 852 2148 3685  
Fax: 852 2148 3085

Email: [hangers.hk@ticgroupasia.com](mailto:hangers.hk@ticgroupasia.com)

**NINGBO**

No 15 Chuang Ye Da Dao  
West District of Free Trade Zone,  
Ningbo, China

Ph: 86 574 2687 3733  
Fax: 86 574 8682 3880

Email: [hangers.cn@ticgroupasia.com](mailto:hangers.cn@ticgroupasia.com)



[www.ticgroup.com.au](http://www.ticgroup.com.au)

CODE	COLOURS	DESCRIPTION	CATEGORY	AUSTRALIA \$ FIS	US \$ FIS	BOX QTY'S
<b>TOPS</b>						
TH40X	BLACK	250mm Top Hanger	Infants	0.1160	0.0820	900
TH40X	WARM GREY	250mm Top Hanger	Infants	0.1160	0.0820	900
TH41X	BLACK	300mm Top Hanger	Childrens	0.1210	0.0860	700
TH41X	WARM GREY	300mm Top Hanger	Childrens	0.1210	0.0860	700
TH42X	BLACK	350mm Top Hanger	Childrens	0.1320	0.0940	670
TH43	BLACK	400mm Top Hanger	Adults	0.1540	0.1090	470
TH43	NATURAL	400mm Top Hanger	Adults	0.1540	0.1090	470
TH45	BLACK	460mm Top Hanger	Adults	0.1760	0.1250	370
TH45	NATURAL	460mm Top Hanger	Adults	0.1760	0.1250	370
TH46	BLACK	520mm Top Hanger	Adults	0.1980	0.1410	260
KN44	BLACK	420mm Knitwear / Jacket Hanger	Adults	0.2420	0.1720	320
KN44	NATURAL	420mm Knitwear / Jacket Hanger	Adults	0.2420	0.1720	320
KN44/AC67	BLACK	420mm Knitwear with sleeve	Adults	0.3850	0.2430	180
KN47	BLACK	460mm Knitwear Hanger	Adults	0.2640	0.1870	290
KN47/AC67	BLACK	460mm Knitwear with sleeve	Adults	0.4070	0.2580	150
SU65	BLACK	460mm Suit Hanger	Menswear	0.8260	0.5860	30
SU86	BLACK	460mm Jacket Hanger	Menswear	0.7480	0.5310	60
4489	BLACK	420mm Jacket Hanger	Ladieswear	0.7480	0.5310	100
<b>SPECIALTY</b>						
FR78	BLACK	250X320mm Frame Hanger	Childrens	0.2200	0.1560	210
FR79	BLACK	250X350mm Frame Hanger	Childrens	0.2420	0.1720	180
FR80	BLACK	350x430mm Frame Hnager	Childrens	0.2970	0.2110	100
TH 40DS	BLACK	155mm x 250mm	Childrens Multi Garments	0.2500	0.1800	500
TH 40DS	WARM GREY	155mm x 250mm	Childrens Multi Garments	0.2500	0.1800	500
TH 41DS	BLACK	155mm x 300mm	Childrens Multi Garments	0.2700	0.1944	450
TH 41DS	WARM GREY	155mm x 300mm	Childrens Multi Garments	0.2700	0.1944	450
TH 42DS	BLACK	155mm x 350mm	Childrens Multi Garments	0.2800	0.2010	400
TP89	BLACK	210mm 1 Prong Hanger	Childrens Multi Garments	0.0950	0.0720	2000
TP89	WARM GREY	210mm 1 Prong Hanger	Childrens Multi Garments	0.0950	0.0720	2000
TP90	BLACK	210mm 2 Prong Hanger	Childrens Multi Garments	0.1000	0.0760	1600
TP90	WARM GREY	210mm 2 Prong Hanger	Childrens Multi Garments	0.1000	0.0760	1600
TP91	BLACK	210mm 3 Prong Hanger	Childrens Multi Garments	0.1200	0.0910	1300
TP91	WARM GREY	210mm 3 Prong Hanger	Childrens Multi Garments	0.1200	0.0910	1300
TP95	BLACK	210mm 5 Prong Hanger	Childrens Multi Garments	0.1600	0.1200	400

**Lead Times:** **AUSTRALIA:-** From receipt of order despatch time is 2 business days.  
**CHINA:-** Despatch 3 business days from receipt of all customs documentation.  
**INDIA:-** Despatch 3 business days from receipt of all customs documentation.

**Box Qty's:** All deliveries are full box/bag quantities.

**Payment Terms:** Payment prior to delivery (PPD) or 30 days from date of invoice to approved customers.

**AUSTRALIA****MELBOURNE**

214 Blackshaws Road  
 Altona North Vic, 3025  
 Australia.  
 Ph: 613 9393 3737  
 Fax: 613 9393 3778

Email: [hangers@ticgroup.com.au](mailto:hangers@ticgroup.com.au)

**SYDNEY**

Unit 3, 79 Williamson Road  
 Ingleburn, 2565, NSW  
 Australia  
 Ph: 612 9618 5133  
 Fax: 612 9618 5733

Email: [hangers.syd@ticgroup.com.au](mailto:hangers.syd@ticgroup.com.au)

**ASIA****HONG KONG**

Unit 3,5,6 and 7, 29/F Saxon Tower,  
 7 Cheung Shun Street,  
 Lai Chi Kok, Kowloon Hong Kong.  
 Ph: 852 2148 3685  
 Fax: 852 2148 3085

Email: [hangers.hk@ticgroupasia.com](mailto:hangers.hk@ticgroupasia.com)

**NINGBO**

No 15 Chuang Ye Da Dao  
 West District of Free Trade Zone,  
 Ningbo, China  
 Ph: 86 574 2687 3733  
 Fax: 86 574 8682 3880

Email: [hangers.cn@ticgroupasia.com](mailto:hangers.cn@ticgroupasia.com)



[www.ticgroup.com.au](http://www.ticgroup.com.au)

CODE	COLOURS	DESCRIPTION	CATEGORY	AUSTRALIA \$ FIS	US \$ FIS	BOX QTY'S
<b><u>BOTTOMS</u></b>						
BH60	BLACK	210mm Bottom Clip Hanger	Childrens	0.2320	0.1650	450
BH64	BLACK	260mm Bottom Clip Hanger	Childrens	0.2540	0.1800	340
BH61	BLACK	280mm Bottom Clip Hanger	Childrens	0.2750	0.1950	340
BH61	NATURAL	280mm Bottom Clip Hanger	Childrens	0.2750	0.1950	340
BH61L	BLACK	280mm Bottom Clip Hanger with Loop	Childrens	0.2750	0.1950	340
BH62	BLACK	310mm Bottom Clip Hanger	Adults	0.2970	0.2110	340
BH62	NATURAL	310mm Bottom Clip Hanger	Adults	0.2970	0.2110	340
BH63	BLACK	350mm Bottom Clip Hanger	Adults	0.3190	0.2260	290
PH54X	BLACK	190mm Prong Hanger	Childrens	0.1320	0.0940	560
PH54X	WARM GREY	190mm Prong Hanger	Childrens	0.1320	0.0940	560
PH54XL	BLACK	190mm Prong Hanger with Loop	Childrens	0.1320	0.0940	420
PH54XL	WARM GREY	190mm Prong Hanger with Loop	Childrens	0.1320	0.0940	420
PH55X	BLACK	250mm Prong Hanger	Childrens	0.1770	0.1260	410
PH55XL	BLACK	250mm Prong Hanger with Loop	Childrens	0.1770	0.1260	320
FL57	BLACK	280mm Bottom Fox Lock Hanger	Adults	0.2860	0.2030	250
FL58	BLACK	310mm Bottom Fox Lock Hanger	Adults	0.3080	0.2190	240
FL59	BLACK	350mm Bottom Fox Lock Hanger	Adults	0.3300	0.2340	210
BSL82	BLACK	310mm Bottom Soft Lock Peg Hanger	Adults	0.3520	0.2500	340
BH81X	BLACK	340mm Trouser Hanger	Adults	0.3850	0.2730	350
<b><u>HANGER ACCESSORIES</u></b>						
AC16	ASSTD	Size Clips	All Groups	0.0130	0.0092	200
AC18N	ASSTD	Metal Hook Size Clips	All Groups	0.0700	0.0500	200
AC21	ASSTD	Size Tabs - Footwear	All Groups	0.0080	0.0057	1000
AC22	ASSTD	Size Tabs - Lingerie	All Groups	0.0080	0.0057	1000
AC65	BLACK	90X70mm Hook & Loop	All Groups	0.0220	0.0160	100
AC69	BLACK	152mm Hook & Loop	All Groups	0.0610	0.0430	100
AC66	BLACK	250X70mm Hook & Loop	All Groups	0.0670	0.0480	100
AC67	DARK GREY	Foam Sleeves ( per pair)	Adults	0.1000	0.0710	580
AC67C	DARK GREY	Childrens Foam Sleeves ( per pair)	Adults	0.1000	0.0710	580
AC80	ASSORTED	Brand Plate	All Groups	0.0500	0.0360	50

**Lead Times:** **AUSTRALIA:-** From receipt of order despatch time is 2 business days.  
**CHINA:-** Despatch 3 business days from receipt of all customs documentation.  
**INDIA:-** Despatch 3 business days from receipt of all customs documentation.

**Box Qty's:** All deliveries are full box/bag quantities.

**Payment Terms:** Payment prior to delivery (PPD) or 30 days from date of invoice to approved customers.

**MELBOURNE**

214 Blackshaws Road  
Altona North Vic, 3025  
Australia.

Ph: 613 9393 3737  
Fax: 613 9393 3778

Email: [hangers@ticgroup.com.au](mailto:hangers@ticgroup.com.au)

**AUSTRALIA****SYDNEY**

Unit 3, 79 Williamson Road  
Ingleburn, 2565, NSW  
Australia

Ph: 612 9618 5133  
Fax: 612 9618 5733

Email: [hangers.syd@ticgroup.com.au](mailto:hangers.syd@ticgroup.com.au)

**ASIA****HONG KONG**

Unit 3,5,6 and 7, 29/F Saxon Tower,  
7 Cheung Shun Street,  
Lai Chi Kok, Kowloon Hong Kong.

Ph: 852 2148 3685  
Fax: 852 2148 3085

Email: [hangers.hk@ticgroupasia.com](mailto:hangers.hk@ticgroupasia.com)

**NINGBO**

No 15 Chuang Ye Da Dao  
West District of Free Trade Zone,  
Ningbo, China

Ph: 86 574 2687 3733  
Fax: 86 574 8682 3880

Email: [hangers.cn@ticgroupasia.com](mailto:hangers.cn@ticgroupasia.com)



[www.ticgroup.com.au](http://www.ticgroup.com.au)

CODE	COLOURS	DESCRIPTION	CATEGORY	AUSTRALIA \$ FIS	US \$ FIS	BOX QTY'S
<b>LINGERIE</b>						
LH 34	CRYSTAL	250mm Brief Hanger	Ladieswear	0.0620	0.0440	1200
LH 34	BLACK	250mm Brief Hanger	Menswear	0.0620	0.0440	1200
LH35	BLACK	210mm Brief Hanger	Childrenswear	0.0480	0.0340	1400
LH85	BLACK	270mm Sets	Menswear	0.0690	0.0490	1100
LH85	CRYSTAL	270mm Camisole and Sets	Ladieswear	0.0690	0.0490	1100
LH88	BLACK	250mm Lingerie 2 pce Sets	Adults	0.0900	0.0640	1000
LH88	CRYSTAL	250mm Lingerie 2 pce Sets	Adults	0.0900	0.0640	1000
LH89	CRYSTAL	265mm Brief Hanger	Adults	0.0720	0.0510	1700
LH76	BLACK	310mm Brief Hanger	Menswear	0.0690	0.0490	1000
LH76	CRYSTAL	310mm Brief Hanger	Menswear	0.0690	0.0490	1000
LH75	BLACK	210mm Brief, Camisole & Underwear Hanger	Childrenswear	0.0590	0.0420	1400
LH93CR	CRYSTAL	225mm 3 Garment Hanger	Adults	0.1250	0.0890	800
LH93BL	BLACK	225mm 3 Garment Hanger	Adults	0.1250	0.0890	800
BR 32	CRYSTAL	285mm Bra Hanger	Youth & Ladieswear	0.0620	0.0440	1100
BR33	CRYSTAL	335mm Bra Hanger	Ladieswear	0.0690	0.0490	1000
<b>SCARF</b>						
SC 27	BLACK	35mm Small Scarf Hanger	All Groups	0.0550	0.0390	2300
SC28	BLACK	50mm Large Scarf Hanger	All Groups	0.0610	0.0430	2000
SC 71	BLACK	225mm Small Shawl Hanger	All Groups	0.1270	0.0900	1000
SC 29	BLACK	300mm Shawl Hanger	Adults	0.1320	0.0940	540
SC 70	BLACK	Round Scarf Hanger	All Groups	0.0880	0.0620	500
AC 30	BLACK	Gun Hook	All Groups	0.0330	0.0230	8000
AC 30	WARM GREY	Gun Hook	All Groups	0.0330	0.0230	8000

**Lead Times:**  
**AUSTRALIA:-** From receipt of order despatch time is 2 business days.  
**CHINA:-** Despatch 3 business days from receipt of all customs documentation.  
**INDIA:-** Despatch 3 business days from receipt of all customs documentation.

**Box Qty's:** All deliveries are full box/bag quantities.

**Payment Terms:** Payment prior to delivery (PPD) or 30 days from date of invoice to approved customers.

**AUSTRALIA****MELBOURNE**

214 Blackshaws Road  
Altona North Vic, 3025  
Australia.

Ph: 613 9393 3737

Fax: 613 9393 3778

Email: [hangers@ticgroup.com.au](mailto:hangers@ticgroup.com.au)

**SYDNEY**

Unit 3, 79 Williamson Road  
Ingleburn, 2565, NSW  
Australia

Ph: 612 9618 5133

Fax: 612 9618 5733

Email: [hangers.syd@ticgroup.com.au](mailto:hangers.syd@ticgroup.com.au)

**ASIA****HONG KONG**

Unit 3,5,6 and 7, 29/F Saxon Tower,  
7 Cheung Shun Street,  
Lai Chi Kok, Kowloon Hong Kong.

Ph: 852 2148 3685

Fax: 852 2148 3085

Email: [hangers.hk@ticgroupasia.com](mailto:hangers.hk@ticgroupasia.com)

**NINGBO**

No 15 Chuang Ye Da Dao  
West District of Free Trade Zone,  
Ningbo, China

Ph: 86 574 2687 3733

Fax: 86 574 8682 3880

Email: [hangers.cn@ticgroupasia.com](mailto:hangers.cn@ticgroupasia.com)



[www.ticgroup.com.au](http://www.ticgroup.com.au)

CODE	COLOURS	DESCRIPTION	CATEGORY	AUSTRALIA \$ FIS	US \$ FIS	BOX QTY'S
<b><u>FOOTWEAR</u></b>						
FW 24	BLACK	115mm Thong Hanger	All Groups	0.0720	0.0510	2200
FW 25	BLACK	170 mm Multi Purpose Hanger	All Groups	0.0940	0.0670	600
FW 77	BLACK	195mm Multi Purpose Hanger	All Groups	0.0940	0.0670	500
FW26	BLACK	215mm Multi Purpose Hanger	All Groups	0.0940	0.0670	400
FW92	BLACK	280mm Multi Purpose Hanger	All Groups	0.1400	0.1000	240
FW22	BLACK	90mm U End Hanger	All Groups	0.0740	0.0530	2300
FW 23	BLACK	70mm U End Hanger	Childrens	0.0720	0.0510	2000
FW 75	BLACK	120mm U End Hanger	All Groups	0.0930	0.0660	1200
FW 78	BLACK	180mm Boot Hanger	All Groups	0.1980	0.1410	500
FW79N	BLACK	170mm Boot Hanger	All Groups	0.1980	0.1410	500
FW80	BLACK	295mm Multi Purpose	All Groups	0.1300	0.0920	300
<b><u>PREMIUM</u></b>						
44H52	BLACK	Wire Hook Top Hanger	ADULTS	0.2320	0.1650	240
44H53	BLACK	Wire Hook Top Hanger	ADULTS	0.2320	0.1650	200
4455	BLACK	Wire Hook Top Hanger	ADULTS	0.2570	0.1820	320
4456	BLACK	Wire Hook Top Hanger	ADULTS	0.2570	0.1820	320
4473	BLACK	Wire Hook Bottom Soft Lock Clip	ADULTS	0.4410	0.3130	288

**Lead Times:** **AUSTRALIA:-** From receipt of order despatch time is 2 business days.  
**CHINA:-** Despatch 3 business days from receipt of all customs documentation.  
**INDIA:-** Despatch 3 business days from receipt of all customs documentation.

**Box Qty's:** All deliveries are full box/bag quantities.

**Payment Terms:** Payment prior to delivery (PPD) or 30 days from date of invoice to approved customers.