

BIGW

Operating Manual for Garment Hangers

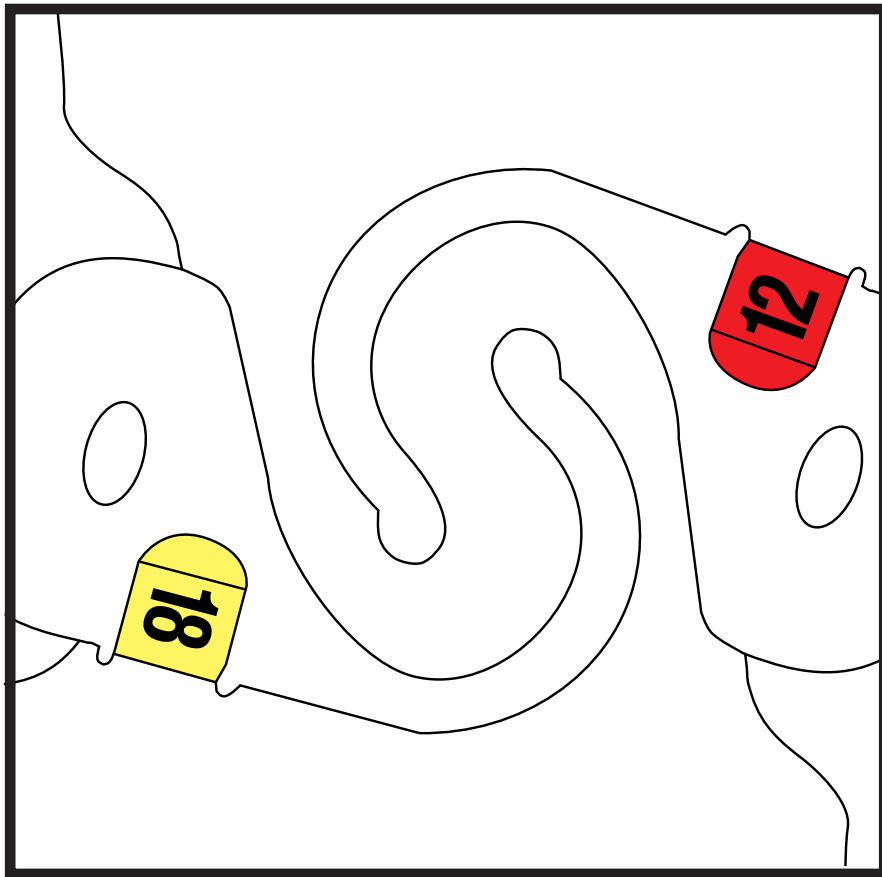

1. Introduction

The Big W hanger range consists of black garment, lingerie, black fashion accessories and black footwear hangers. All these hangers can take the form of merchandise delivered hanging, in bags, or included with merchandise flat packed in cartons.

This manual has been compiled for Suppliers, Quality Assurance, and Buying Office Personnel.

The Buying Office is responsible to select the most appropriate hanger to suit merchandise for floor ready presentation.

IMPORTANT NOTICE:

To ensure integrity and consistency for Big W from the 1st August 2007, all hangers and accessories **MUST** be purchased from TIC, the only approved Service Provider for Big W hangers and accessories. Please note this is a requirement for conducting business with Big W.

Failure by suppliers to comply with these conditions post 1st August 2007 will represent a substantial breach of Big W conditions of supply and penalties may apply if infringements occur. Big W will monitor compliance through monthly reporting procedures and store audits, to ensure the objectives are met.

The hangers and accessories are the registered intellectual property of TIC, and as such, suppliers are not permitted to copy or reproduce these by any means.

2 Ordering

Big W request that suppliers place orders by accessing the TIC website and following the prompts. To use the online ordering system, suppliers must be registered with TIC, and be issued with a password. All orders placed online will be automatically confirmed by return email. **All orders will be rounded up to the nearest full carton.**

It is the Suppliers and/or Agents responsibility to ensure that the hanger specified by Big W is the only hanger used on Big W garments and that the colour coded size labeling system is used correctly.

2.1 Australia, New Zealand, Fiji, and Pacific Basin.

Orders can only be placed on-line by logging on to www.ticgroup.com.au and follow the prompts. All orders placed online will be automatically confirmed by return email.

Lead Times – all orders will be processed and despatched within 2 business days.

Upon receipt of this package it is advised that Australian manufacturers and Australian based importers need to apply to TIC for a credit application form.

2.2 China, other Asian and European countries

Orders should be placed on-line by logging on to www.ticgroupasia.com and follow the prompts. All orders placed online will be automatically confirmed by return email.

Lead Times: On receipt of all **approved Customs documentation** from the customs office, orders will be processed for dispatch **within 3 working days**.

Important Note for China only: Chinese Customs Documentation supporting the export of these hangers must be supplied to TIC before orders can be processed.

3. Customs

3.1 Australia and New Zealand Customs Requirements:

Importers should ensure that the hanger cost is shown separately on Import Invoices and as a separate entry on the Import Duty Warrant under tariff item 93924-900-00 at 5% duty. All apparel merchandise invoices must include a declaration as per the following example:

Example:

“The unit cost of hangers, of Chinese origin, included on order 1234567 is US\$0.15 each and this cost is included in the invoice cost per unit of the product.”

Overseas suppliers and Australian importers should ensure that the hanger cost (per unit) and hanger origin is shown on the invoice.

If you have any queries, please contact the TIC (Retail Accessories) office. We suggest that you also consult with your Customs Agent.

3.2 China

Upon receipt of orders at TIC, a fax, accompanied by a telephone call is made to Suppliers, requesting a copy of their Customs Documentation.

From receipt of all Customs documentation goods are despatched within 3 business days.

3.3 Other Countries

For hangers imported into other countries it is the responsibility of the Importer to ensure correct customs procedures are followed. Freight, all associated shipping costs, duties etc. are the responsibility of suppliers when receiving good in “Other Countries.”

4. Payment Terms

4.1 Australian and New Zealand Suppliers/Importers

- Suppliers who do not have a credit facility with TIC will be required to pay for goods prior to delivery. IE. Payment Pre Delivery (PPD).
- For a Trading Account / Credit. Suppliers must complete the Supplier Registration Form and submit to TIC (Refer to Appendix A). If credit is approved by TIC, terms of payment are 30 days from invoice.
- Subject to approval by TIC, where an Australian based importer requires delivery to their overseas manufacturer, the Australian based importer may receive trading terms of 30 days from invoice.

4.2 Big W – Overseas Manufacturers

- Approved Big W direct overseas suppliers may receive credit terms of 30 days from invoice, subject to a credit approval by TIC.

4.3 Other Overseas Agents and Manufacturers

- Overseas Agents and Manufacturers who supply Big W Importers will receive goods on a PPD (payment pre delivery) basis, unless a previous Application for Credit has been approved.

Note: If invoices are not paid within 30 days from the date of invoice, no further deliveries will be made.

When making payment – a remittance advice with full payment details is required.

Suppliers please note that TIC banking details are clearly displayed on all TIC invoices.

5. TIC GROUP CONTACT INFORMATION

TIC Group – Melbourne Office (Head Office)

214 Blackshaws Road
Altona North VIC Australia 3025
Telephone: (03) 9393 3737
Toll Free: 1800 790 110
Facsimile Number: (03) 9393 3778
Email: hangers@ticgroup.com.au
Web: www.ticgroup.com.au

TIC Group – Sydney (Sales Office)

Unit 3, 79 Williamson Road,
Ingleburn NSW Australia 2565
Telephone Number: (02) 9618 5133
Facsimile Number: (02) 9618 5733
Email: hangers.syd@ticgroup.com.au
Web: www.ticgroup.com.au

All deliveries are ex TIC Melbourne National Warehouse.
All invoices will be issued in AUD\$ currency.

TIC Group – Hong Kong Office

Unit 3, 5, 6 and 7, 29/F Saxon Tower,
7 Cheung Shun Street,
Lai Chi Kok, KOWLOON,
HONG KONG
Telephone: (852) 2148 3685
Facsimile Number: (852) 2148 3085
Email: hangers.hk@ticgroupasia.com
Web: www.ticgroupasia.com

TIC Group–Ningbo Office (Represented by Ningbo Xunxing Trade Co Ltd)

No 15 Chuang Ye Da Dao
West District of Free Trade Zone,
Ningbo, China
Telephone: 86 574 2687 3733
Facsimile Number: 86 574 8682 3880
Email: hangers.cn@ticgroupasia.com
Web: www.ticgroupasia.com

TIC Group–Shanghai Office

Unit E, 17/Floor, Hengji Plaza
No 99 East Huaihai Road
Huangpu District
200021, Shanghai, China
Telephone: 86 21 6386 0808 extn 316
Facsimile Number: 86 21 6386 9511 / 6386 9533
Email: hangers.cn@ticgroupasia.com
Web: www.ticgroupasia.com

All invoices will be issued in US\$ currency.



TIC (Retail Accessories) Pty Ltd.

232 Blackshaws Road, Victoria, Australia 3025

Phone: 613 9393 3737

Fax: 613 9392 2332

Email: hangers@ticgroup.com.au

ABN: 31 007 422 291

REGISTRATION FOR AUSTRALIAN, NEW ZEALAND BASED AND PACIFIC RIM MANUFACTURERS AND IMPORTERS

If granted a trading account(s) the Applicant agrees to conduct this/these account(s) within TIC (Retail Accessories) Pty Ltd. trading terms as they apply from time to time.

TRADING DETAILS:

ABN:

Trading Name:.....

Trading Address:.....

.....Postcode/Zip Code:.....

Phone:.....Fax:.....

Email:

IF SOLE TRADER/PARTNERSHIP (Complete this Section)

Owner's Name:.....

Private Address:.....

Phone:.....Date of Birth:.....Drivers Licence Number:.....

Owner's Name:.....

Private Address:.....

Phone:.....Date of Birth:.....Drivers Licence Number:.....

IF A COMPANY (Complete this Section)

Company

Name:.....

Registered

Address:.....

.....**Phone:**.....

Business License Number:.....

DETAILS OF DIRECTORS:

Name:.....

Private

Address:.....

Phone:.....

Name:.....

Private

Address:.....

Phone:.....

Name:.....

Private

Address:.....

Phone:.....

BANK DETAILS:

Bank:.....**Branch:**.....

Account Name:.....

Account Number:.....

Monthly Credit Applied For:.....

Anticipated Annual Spend A\$:.....

BUSINESS REFERENCES:

Name:.....

Address:.....

Phone:..... **Fax:**.....

Monthly Spend A\$.....

Name:.....

Address:.....

Phone:..... **Fax:**.....

Monthly Spend A\$.....

Name:.....

Address:.....

Phone:..... **Fax:**.....

Monthly Spend A\$.....

PLEASE READ CAREFULLY BEFORE SIGNING

I/We the undersigned hereby request that TIC (Retail Accessories) supply goods to me in consideration of TIC (Retail Accessories) agreeing to do so. I/We hereby jointly and severally warrant to and covenant with TIC (Retail Accessories) as follows;

1. That all information contained herein is true and correct in every particular and that all material facts have been disclosed to TIC (Retail Accessories).
2. That payments for all goods supplied by TIC (Retail Accessories) will be made strictly in accordance with the trading terms applicable from time to time.
3. If the applicant is a company then provision of a trading account pursuant to this application is subject to and conditional upon the applicant's directors executing a Guarantee in the form approved.
4. The undersigned and any director or principal of the applicant have never been made bankrupt and are solvent and are able to pay their debts as they fall due and have not made any compromise or arrangement with their creditors and no application has been made or proposed to a summon meeting of their creditors or any class of them.
5. That the applicant (if a corporation) is solvent and able to pay its debts as they fall due and is not in liquidation or being wound up and no meeting has been called or resolution has been passed or order made for such purposes and no Receiver or Receiver Manager has been appointed in respect of the applicant and the applicant has not made any compromise or arrangement with its creditors or any class of them and no application has been proposed or made to any court for an order summoning a meeting of its creditors or any class of them.
6. That the applicant hereby acknowledges receipt for TIC (Retail Accessories) Terms of Trade, as they presently exist.

Dated the:..... day of.....20.....

SOLE TRADER (SIGNATURE):.....

PARTNERS (SIGNATURE):.....

THE COMMON SEAL of)
was hereunto affixed)
in accordance with its Articles of)
Association in the presence of)

.....Director

.....Secretary

TIC (Retail Accessories) Pty Ltd.
51 Regan Street, St. Albans, Victoria, Australia 3021

Your Authorised TIC Webpage Password

IN CONSIDERATION of you having agreed or agreeing to sell goods or provide services or extend credit to the party named in the Schedule hereto as the debtor (herein after called "the debtor" we, the parties named in the Schedule hereto as he Guarantors JOINTLY AND SEVERALLY GUARANTEE the due and punctual payment to you by the debtor of all monies now and hereafter payable to the debtor to you on any account whosoever whether such sale, provision or extension shall have occurred or been made before or after the execution of this instrument and whether or not the said agreement to sell goods, provide services or extend credit, may be or become void or voidable or unenforceable by law. WE JOINTLY AND SEVERALLY INDEMINIFY you against all loss and damage suffered by you by reason of a failure of the debtor duly to perform any obligation on its part arising out of or in connection with such sale, provision or extension AND WE EXPRESSLY ACKNOWLEDGE AND DECLARE that this Guarantee is given upon the following conditions:

1. The certificate of your Secretary, Credit Manager or Solicitors for the time being stating the amount or amounts due and owing to you by the debtor in relation to such sale, provision or extension shall be conclusive evidence of the indebtedness of the debtor to you as the date stated in such certificate.
2. Our liability to you hereafter shall not be affected by time or any other indulgence granted to you by the debtor or by modification or variation in the terms of sale, provision or extension. You may at such time as you think fit cease to sell goods to or provide services for or extend credit to the debtor.
3. The guarantee hereby given shall be a continuing guarantee and shall bind our executors and administrators.
4. Any demand on us hereunder may be duly made if it is in writing signed by your Secretary, Credit Manager or Solicitors and is given to or left for us at or posted to one of our addresses set out as below or to such other addresses as we may from time to time notify you in writing, PROVIDED THAT it shall not be a condition precedent to the exercise of your rights against us hereunder that any demand or notice will be given to us.
5. Except where the context forbids words herein importing the plural shall include the singular and vice versa.
6. Until you have received 100 cents in the dollar in respect of the Guarantee obligations the Guarantor shall not be entitled either directly or indirectly receive the benefit from the administration of the affairs of the debtor in insolvency resulting from the lodging of any proof or make nay claim in respect thereof in competition with you so as to diminish any amount that but for such dividend or other payment that you may receive shall not prejudice your right to recover so much of the guaranteed amounts as have not been paid to you.
7. No monies received by you to the creditor of the debtor and for which you may in any administration in insolvency of the affairs as the debtor be obliged to account to any liquidator, official manager, trustee in bankruptcy may in your discretion be received by you discharge or diminish our liability hereunder.

Conditions of Sale

Interpretation

1. In these conditions:
‘Seller’ means [Tic (Retail Accessories) Pty Ltd] which is the seller of the goods.
‘Buyer’ means the purchaser of the goods specified overleaf.
‘Goods’ means the products and, if any, services specified overleaf.
Nothing in these conditions shall be read or applied so as to exclude, restrict or modify or have the effect of excluding, restricting or modifying any condition, warranty, guarantee, right or remedy implied by law (including the Trade Practices Act 1974) and which by law cannot be excluded, restricted or modified.

General

2. These conditions (which shall only be waived in writing signed by the seller) shall prevail over all conditions of the buyer’s order to the extent of any inconsistency.

Important note: A number of garment hangers, accessories and supporting devices are the subject of Intellectual Property Rights owned by TIC Group Pty Ltd. and/or its affiliates. Any breach of these rights may be the subject of legal action.

Disclaimer: Suppliers have a duty of care to ensure hangers and accessories selected from the TIC range can withstand the particular transport, distribution and handling environments they will be subjected to. Please contact TIC if you require assistance with the selection of hangers or accessories.

Terms of sale

3. The goods and all other products sold by seller are sold on these terms and conditions.

Seller’s quotations

4. Unless previously withdrawn, seller’s quotations are open for acceptance within the period stated in them or, when no period is so stated, within 30 days only after its date. The seller reserves the right to refuse any order based on this quotation within 7 days after the receipt of the order.

Packing

5. The cost of any special packing and packing materials used in relation to the goods are at the buyer’s expense notwithstanding that such cost may have been omitted from any quotation.

Shortage

6. The buyer waives any claim for shortage of any goods delivered if a claim in respect for short delivery has not been lodged with the seller within seven (7) days from the date of receipt of goods by the buyer.

Delivery

7. (a) The delivery times made known to the buyer are estimates only and the seller is not be liable for late delivery or non-delivery.
(b) The seller is not be liable for any loss, damage or delay occasioned to the buyer or its customers arising from late or non-delivery or late installation of the goods.
(c) The seller may at its option deliver the goods to the buyer in any number of instalments unless there is an endorsement overleaf to the effect that the buyer will not take delivery by instalments.
(d) If the seller delivers any of the goods by instalments, and any one of those instalments is defective for any reason:
 - (1) it is not a repudiation of the contract of sale formed by these conditions; and
 - (2) the defective instalment is a severable breach that gives rise only to a claim for compensation.

Loss or damage in transit

8. (a) The seller is not responsible to the buyer or any person claiming through the buyer for any loss or damage to goods in transit caused by any event of any kind by any person (whether or not the seller is legally responsible for the person who caused or contributed to that loss or damage).
(b) The seller must provide the buyer with such assistance as may be necessary to press claims on carriers so long as the buyer:
 - (1) has notified the seller and the carriers in writing immediately after loss or damage is discovered on receipt of goods; and
 - (2) lodges a claim for compensation on the carrier within three (3) days of the date of receipt of the goods.

Prices

9. (a) Unless otherwise stated all prices quoted by the seller are net, exclusive of Goods and Services Tax (GST).
(b) Prices quoted are those ruling at the date of issue of quotation and are based on rates of freight, insurance, customs duties, exchange, shipping expenses, sorting and stacking charges, cartage, rate of wates, cost of materials and other charges affecting the cost of production ruling on the date is made.
(c) If the seller makes any alterations to the price of the goods or to any of their inputs either before acceptance of or during the currency of the contract, these alterations are for the buyer’s account.

Payment

10. The purchase price in relation to goods is payable net and payment of the price of the goods must be made on or before thirty days from date of the delivery of the goods unless other terms of payment are expressly stated in these conditions in writing.

Rights in relation to goods

11. The seller reserves the following rights in relation to the goods until all accounts owed by the buyer to the seller are fully paid:

- (1) ownership of the goods;
- (2) to enter the buyer’s premises (or the premises of any associated company or agent where the goods are located) without liability for trespass or any resulting damage and retake possession of the goods; and
- (3) to keep or resell any goods repossessed pursuant to (2) above.

If the goods are resold by the buyer, the buyer shall hold such part of the proceeds of any such sale as represents the invoice price of the goods sold in a separate identifiable account as the beneficial property of the seller and shall pay such amount to the seller upon request. Notwithstanding the provisions above the seller shall be entitled to maintain an action against the buyer for the purchase price and the risk of the goods shall pass to the buyer upon delivery.

Buyer’s property

12. Any property of the buyer under the seller’s possession, custody or control is completely at the buyer’s risk as regards loss or damage caused to the property or by it.

Storage

13. The seller reserves the right to make a reasonable charge for storage if delivery instructions are not provided by the buyer within fourteen days of a request by the seller for such instructions. The parties agree that the seller may charge for storage from the first day after the seller requests the buyer to provide delivery instructions.

Returned goods

- 14. (a) The seller is not be under any duty to accept goods returned by the buyer and will do so only on terms to be agreed in writing in each individual case.
- (b) If the seller agrees to accept returned goods from the buyer under para (a) of this clause, the buyer must return the goods to the seller at the seller’s place of business referred to at the head of these conditions.

Goods sold

15. All goods to be supplied by the seller to the buyer are as described on the purchase order agreed by the seller and the buyer and the description on such purchase order modified as so agreed prevails over all other descriptions including any specification or enquiry of the buyer.

Cancellation

16. No order may be cancelled except with consent in writing and on terms which will indemnify the seller against all losses.

Default

17. If the Buyer defaults in payment of any monies due to the Seller the Buyer shall at the option of the Seller pay to the Seller interest on the monies in respect of which default in payment has been made calculated at the daily rate being the rate prescribed from time to time pursuant to the Penalty Interest Rates Act 1983 plus 4% together with and in addition to all costs and expenses including legal costs on a solicitor/client basis incurred by the Seller in recovering from the Buyer monies due as a consequence of the default by the Buyer in payment of monies on the due date for payment.

Place of contract

- 18 (a) The contract for sale of the goods is made in the State of Victoria.
- (b) The parties submit all disputes arising between them to the courts of the State of Victoria and any court competent to hear appeals from those courts of first instance.

Signed _____ Position _____

Dated _____



TIC Group – Ningbo Office

(Represented by Ningbo Xunxing Trade Co Ltd)

No 15, Chuang Ye Da Dao,

West District off Free Trade Zone, Ningbo, China

Tel: +86 574 2687 3733

Fax: +86 574 8682 3880

Email: hangers.cn@ticgroupasia.com

REGISTRATION FOR CHINA, SOUTH EAST ASIA, HONG KONG, INDIAN, SUB-CONTINENT, USA AND EUROPEAN BASED MANUFACTURERS AND AGENTS

TRADING DETAILS:

ABN:

Trading Name:.....

Trading Address:.....

.....Postcode/Zip Code:.....

Phone:.....Fax:.....

Email:.....

COMPANY DETAILS (Complete this Section)

Company

Name:.....

Registered

Address:.....

.....**Phone:**.....

Business License Number:.....

DETAILS OF DIRECTORS:

Name:.....

Private

Address:.....

Phone:.....

Name:.....

Private

Address:.....

Phone:.....

BANK DETAILS:
Monthly Credit Applied For:.....
Anticipated Annual Spend:
Bank:.....**Branch:**.....
Account Name:.....
Account Number:.....

Monthly Credit Applied For:.....
Anticipated Annual Spend US\$:.....

PLEASE READ CAREFULLY BEFORE SIGNING

1. Credit will only be given to BIG W suppliers that have been approved by BIG W.
2. All other suppliers must pre-pay for their hangers and accessories.
3. TIC Group (Asia) reserves the right to withhold deliveries of hangers and accessories if the supplier has not pre-paid for their hangers and accessories.
4. TIC Group (Asia) reserves the right to withhold deliveries of hangers and accessories if a supplier granted credit has not settled outstanding invoices within 30 days of the invoice being issued.

Dated the:..... day of.....20.....

COMPANY CHOP HERE

TIC Group – Ningbo Office (Represented by Ningbo Xunxing Trade Co Ltd)
 No 15, Chuang Ye Da Dao, West District of Free Trade Zone, Ningbo, China

Your Authorised TIC Webpage Password

Conditions of Sale

Interpretation

1. In these conditions:
‘Seller’ means TIC Group (Asia) Ltd. which is the seller of the goods.
‘Buyer’ means the purchaser of the goods specified overleaf.
‘Goods’ means the products and, if any, services specified overleaf.

General

2. These conditions (which shall only be waived in writing signed by the seller) shall prevail over all conditions of the buyer’s order to the extent of any inconsistency.

A number of garment hangers, accessories and supporting devices are the subject of intellectual Property Rights owned by TIC Group Pty Ltd. and/or its affiliates. Any breach of these rights may be the subject of legal action.

Disclaimer: Suppliers have a duty of care to ensure hangers and accessories selected from the TIC range can withstand the particular transport, distribution and handling environments they will be subjected to. Please contact TIC if you require assistance with the selection of hangers or accessories.

Terms of sale

3. The goods and all other products sold by seller are sold on these terms and conditions.

Seller’s quotations

4. Unless previously withdrawn, seller’s quotations are open for acceptance within the period stated in them or, when no period is so stated, within 30 days only after its date. The seller reserves the right to refuse any order based on this quotation within 7 days after the receipt of the order.

Packing

5. The cost of any special packing and packing materials used in relation to the goods are at the buyer’s expense notwithstanding that such cost may have been omitted from any quotation.

Shortage

6. The buyer waives any claim for shortage of any goods delivered if a claim in respect for short delivery has not been lodged with the seller within seven (7) days from the date of receipt of goods by the buyer.

Delivery

7. (a) The delivery times made known to the buyer are estimates only and the seller will not be liable for late delivery or non-delivery.
(b) The seller will not be liable for any loss, damage or delay occasioned to the buyer or its customers arising from late or non-delivery or late installation of the goods.
(c) The seller may at its option deliver the goods to the buyer in any number of installments unless there is an endorsement overleaf to the effect that the buyer will not take delivery by installments.
(d) If the seller delivers any of the goods by installments, and any one of those installments is defective for any reason:
 - (1) it is not a repudiation of the contract of sale formed by these conditions; and
 - (2) the defective installment is a severable breach that gives rise only to a claim for compensation.

Loss or damage in transit

8. (a) The seller is not responsible to the buyer or any person claiming through the buyer for any loss or damage to goods in transit caused by any event of any kind by any person (whether or not the seller is legally responsible for the person who caused or contributed to that loss or damage).
(b) The seller must provide the buyer with such assistance as may be necessary to press claims on carriers so long as the buyer:
 - (1) has notified the seller and the carriers in writing immediately after loss or damage is discovered on receipt of goods; and
 - (2) lodges a claim for compensation on the carrier within three (3) days of the date of receipt of the goods.

Prices

9. (a) Prices quoted are those ruling at the date of issue of quotation and are based on rates of freight, insurance, customs duties, exchange, shipping expenses, sorting and stacking charges, cartage, rate of wastes, cost of materials and other charges affecting the cost of production ruling on the date is made.
(b) If the seller makes any alterations to the price of the goods or to any of their inputs either before acceptance of or during the currency of the contract, these alterations are for the buyer’s account.

Payment

10. The purchase price in relation to goods is payable net and payment of the price of the goods must be made on or before thirty days from date of the delivery of the goods unless other terms of payment are expressly stated in these conditions in writing.

Rights in relation to goods

11. The seller reserves the following rights in relation to the goods until all accounts owed by the buyer to the seller are fully paid:

- (1) ownership of the goods;
- (2) to enter the buyer's premises (or the premises of any associated company or agent where the goods are located) without liability for trespass or any resulting damage and retake possession of the goods; and
- (3) to keep or resell any goods repossessed pursuant to (2) above.

If the goods are resold by the buyer, the buyer shall hold such part of the proceeds of any such sale as represents the invoice price of the goods sold in a separate identifiable account as the beneficial property of the seller and shall pay such amount to the seller upon request. Notwithstanding the provisions above the seller shall be entitled to maintain an action against the buyer for the purchase price and the risk of the goods shall pass to the buyer upon delivery.

Buyer's property

12. Any property of the buyer under the seller's possession, custody or control is completely at the buyer's risk as regards loss or damage caused to the property or by it.

Storage

13. The seller reserves the right to make a reasonable charge for storage if delivery instructions are not provided by the buyer within fourteen days of a request by the seller for such instructions. The parties agree that the seller may charge for storage from the first day after the seller requests the buyer to provide delivery instructions.

Returned goods

14. (a) The seller is not under any duty to accept goods returned by the buyer and will do so only on terms to be agreed in writing in each individual case.
- (b) If the seller agrees to accept returned goods from the buyer under paragraph (a) of this clause, the buyer must return the goods to the seller at the seller's place of business referred to at the head of these conditions.

Goods sold

15. All goods to be supplied by the seller to the buyer are as described on the purchase order agreed by the seller and the buyer and the description on such purchase order modified as so agreed prevails over all other descriptions including any specification or enquiry of the buyer.

Cancellation

16. No order may be cancelled except with consent in writing and on terms which will indemnify the seller against all losses.

Signed _____ Position _____

Dated _____

BIGW HANGER STANDARDS



LADIESWEAR

- TH42 - 350mm**
▶ Sleepwear, spencers, camisoles & slips
- TH43 - 400mm**
▶ Tops, blouses, dresses, sleepwear, spencers and vests
- TH45 - 460mm**
▶ Tops, blouses, dresses, lightweight jackets, pyjamas & satin gowns
- KN44 - 420mm**
▶ Knitwear, lightweight jackets, coats and parkas
- SU86 - 460mm**
▶ Jackets
- KN47 - 460mm**
▶ Knitwear, lightweight jackets, coats and parkas
- BH62 - 310mm**
▶ Pants, skirts, shorts
- BH63 - 350mm**
▶ Pants, skirts, shorts
- BH61 - 280mm**
▶ Pants, skirts, shorts & sets
- BSL82 - 310mm**
▶ Pants, skirts, shorts & sets

MENSWEAR

- TH45 - 460mm**
▶ Tops, shirts, lightweight jackets & pyjamas
- KN47 - 460mm**
▶ Knitwear, lightweight jackets, coats and parkas
- SU86 - 460mm**
▶ Jackets
- BH62 - 310mm**
▶ Pants & shorts
- BH63 - 350mm**
▶ Pants & shorts
- BH99 - 360mm**
▶ Trousers
- BSL82 - 310mm**
▶ Pants & shorts
- TH45D - 460mm**
▶ Multi Garments / Sets

CHILDRENSWEAR

- TH40 - 250mm**
▶ Tops, shirts, dresses, knitwear, jackets, jumpsuits, overalls, etc
- TH41 - 300mm**
▶ Tops, shirts, dresses, knitwear, jackets, jumpsuits, overalls, etc
- TH42 - 350mm**
▶ Tops, shirts, dresses, knitwear, jackets, jumpsuits, overalls, etc
- TH43 - 400mm**
▶ Tops, shirts, dresses, knitwear, jackets, jumpsuits, overalls, etc
- FR78 - 250mm x 320mm**
▶ 2 piece sets
- FR79 - 250mm x 350mm**
▶ 2 piece sets
- PH54 - 190mm**
▶ Pants, skirts, shorts & sets
- PH55 - 260mm**
▶ Pants, skirts, shorts & sets
- BH60 - 210mm**
▶ Pants, skirts, shorts, etc
- BH61 - 280mm**
▶ Pants, skirts, shorts & sets
- BH97 - 320mm**
▶ Pants
- TH40D - 250mm**
▶ Multi sets
- TH42D - 350mm**
▶ Multi sets
- TP90 - 210mm**
▶ 2 prong multi
- TP91 - 210mm**
▶ 3 prong multi
- LH94 - 180mm**
▶ Leggings

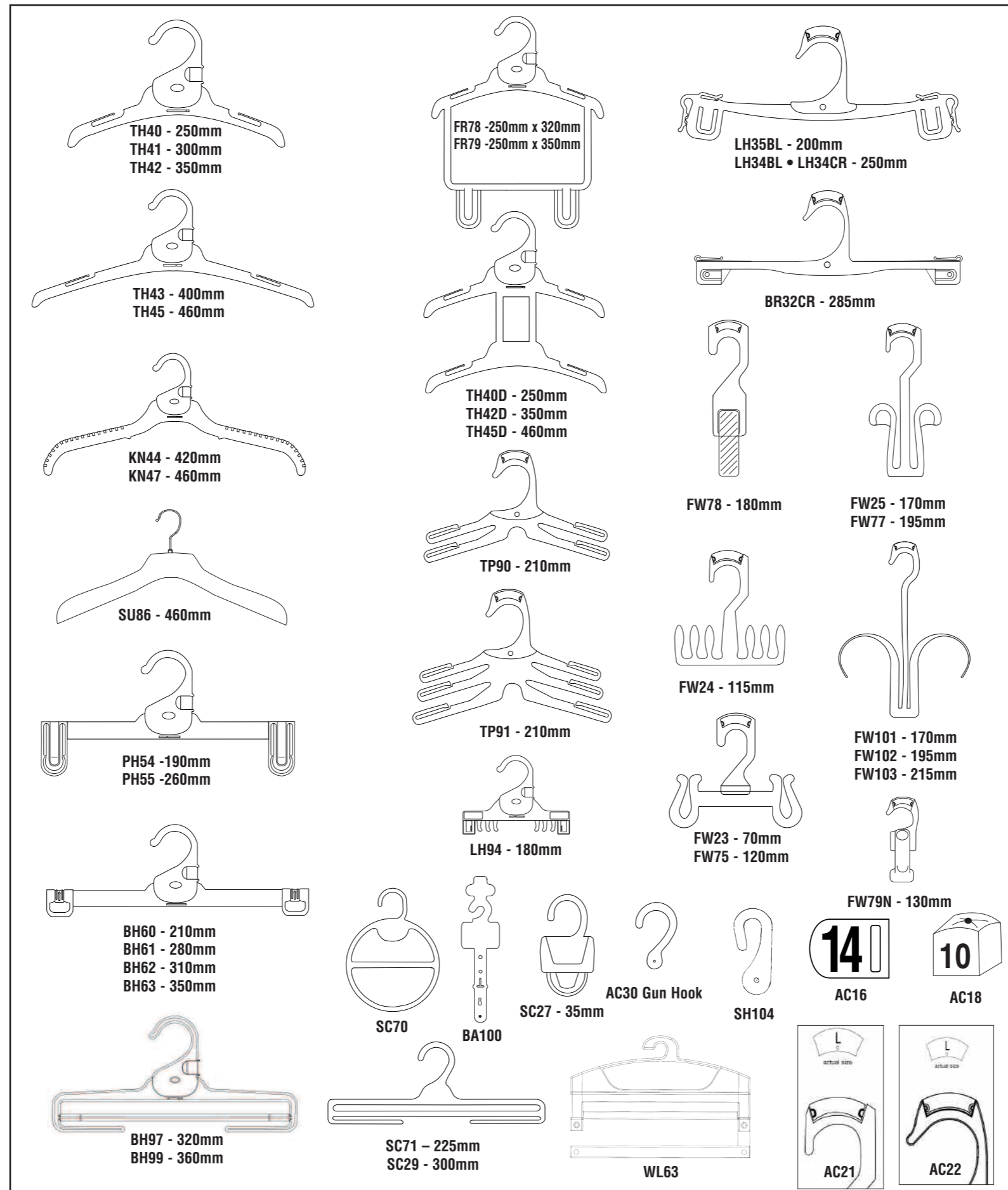

LINGERIE

- WOMEN**
LH34BL - 250mm (Black)
▶ Swimwear & activewear
LH34CR - 250mm (Crystal)
▶ Briefs and Bras
BR32CR - 285mm (Crystal)
▶ Bras
- MEN**
LH34BL - 250mm (Black)
▶ Briefs and swimwear
- CHILDREN**
LH35BL - 200mm (Black)
▶ Briefs, camisole and underwear sets

FOOTWEAR

- FW24 - 115mm
▶ Thongs
- FW23 - 70mm
▶ Childrens casual, canvas, court shoes
- FW75 - 120mm
▶ Adult casual, canvas, court shoes
- FW25 - 170mm
▶ Multi purpose shoes, slippers and scuffs
- FW79N - 170mm
▶ Boots
- FW101 - 170mm
▶ Gooseneck; shoes, slippers and scuffs
- FW102 - 195mm
▶ Gooseneck; shoes, slippers and scuffs
- FW103 - 215mm
▶ Gooseneck; shoes, slippers and scuffs
- FW77 - 195mm
▶ Multi purpose shoes, slippers and scuffs
- FW78 - 180mm
▶ Boots

ACCESSORIES

- SC27 - 35mm
▶ Small
- SC29 - 300mm
▶ Shawls and scarves
- SC71 - 225mm
▶ Shawls and scarves
- SC70 - Round
▶ Shawls and scarves
- AC30 - Gun Hook
- BA100
▶ Belts
- WL63
▶ Wallets
- SH104 - Sock Hanger 45mm
▶ Socks

SIZE CLIPS

- AC16 - Size Clips
- AC18 - Size Clips Metal Hook
- AC22 - Lingerie Size Tab
- AC21 - Footwear Size Tab

FOR RETURNS CONTACT TIC GROUP 1800 790 110



HANGER INDEX

Category	Code	Colour	Description
Tops	TH40X	Black	Infants Top Hanger - 250mm
	TH41X	Black	Infants Top Hanger - 300mm
	TH42X	Black	Youth Top Hanger - 350mm
	TH43	Black	Adult Top Hanger - 400mm
	TH45	Black	Adult Top Hanger - 460mm
	TH46	Black	Adult Top Hanger - 520mm
	KN44	Black	Adult Knitwear Hanger - 420mm
	KN47	Black	Adult Knitwear Hanger - 460mm
	SU86	Black	Adult Jacket Hanger - 460mm
Frame	FR78	Black	Infants Frame Hanger 250 x 320mm
	FR79	Black	Infants Frame Hanger 250 x 350mm
	FR80	Black	350mm x 430mm
	TH40D	Black	Multi Set Hanger - 250mm
	TH42D	Black	Multi Set Hanger - 350mm
	TH45D	Black	Multi Set Hanger - 460mm
	TP90	Black	2 Prong Hanger - 210mm
	TP91	Black	3 Prong Hanger - 210mm
Bottoms	BH60	Black	Childrens Bottom Clip Hanger - 210mm
	BH61	Black	Childrens Bottom Clip Hanger - 280mm
	BH62	Black	Adult Bottom Clip Hanger - 310mm
	BH63	Black	Adult Bottom Clip Hanger - 350mm
	PH54	Black	Prong Hanger - 190mm
	PH55	Black	Prong Hanger - 260mm
	BSL82	Black	Adult Bottom Soft Lock Peg Hanger 310mm
	BH97	Black	Trouser Hanger - 320mm
	BH99	Black	Trouser Hanger - 360mm
		LH94	Black
Lingerie	BR32	Crystal	Bra Hanger 285mm
	LH34	Crystal	Adult Brief Hanger - 250mm
	LH34	Black	Adult Brief Hanger - 250mm
	LH35	Black	Childrens Brief Hanger - 200mm
Footwear	FW24	Black	Thong Hanger - 115mm
	FW25	Black	Multi Purpose Hanger - 170mm
	FW77	Black	Multi Purpose Hanger - 195mm
	FW101	Black	Goose Neck Hanger - 170mm
	FW102	Black	Goose Neck Hanger - 195mm
	FW103	Black	Goose Neck Hanger - 215mm
	FW23	Black	U End Hanger - 70mm
	FW75	Black	U End Hanger - 120mm
	FW78	Black	Boot Hanger - 180mm
		FW79N	Black
Scarfe	SC27	Black	35mm
	SC70	Black	Round Scarf Hanger - 130 x 170mm
	SC71	Black	225mm Shawl
	SC29	Black	300mm Shawl
	SH104	Black	45mm Sock Hook
	AC30	Black	Gun Hook
Belt	BH100	Black	170mm
Wallet	WL63	Black	110mm
Access.	AC16	Asstd	Garments Sizing Clip
	AC16	Asstd	Garment Sizing Range
	AC18	Asstd	Metal Hook Sizing Clip
	AC18	Asstd	Metal Hook Sizing Range
	AC22	Asstd	Lingerie Sizing Tabs
	AC22	Asstd	Lingerie Sizing Range
	AC21	Asstd	Footwear Sizing Tabs
	AC21	Asstd	Footwear Sizing Range
	AC67	Black	Foam Sleeves
	AC65	Black	Hook & Loop
Price List			



HANGER CODE CONVERSION CHART



CURRENT HANGER CODE	NEW HANGER CODE	DESCRIPTION
TOPS HANGERS		
TH 9	TH 40X	Infant Top Hanger 250mm
TH 10	TH 41X	Infant Top Hanger 300mm
TH 11	TH 42X	Youth Top Hanger 350mm
SH 7	TH 43	Adult Top Hanger 400mm
SH 8	TH 45	Adult Top Hanger 460mm
KN 6	KN44	Adults Knitwear Hanger 420mm
KN 6	KN47	Adults Knitwear Hanger 460mm
KN 6	SU86	Adults Jacket Hanger 460mm
BOTTOMS HANGERS		
PH 20	PH 54X	Prong Hanger 190mm
PH 21	PH 55X	Prong Hanger 260mm
BH 4	BH 60	Childs Bottom Clip Hanger 210mm
BH 3	BH 61	Childs Bottom Clip Hanger 280mm
BH 2	BH 62	Adult Bottom Clip Hanger 310mm
BH 1	BH 63	Adult Bottom Clip Hanger 350mm
NEW	BSL 82	Adult Bottom Soft Lock Peg Hanger 310mm
NEW	BH 97	Childs Trouser Hanger 280mm TBC
NEW	BH 99	Adult Trouser Hanger 340mm
LINGERIE HANGERS		
BR 32	BR 32	Bra Hanger 285mm
LH 34CR	LH 34CR	Adult Brief 250mm - Crystal
LH 34BL	LH 34BL	Adult Brief 250mm - Black
LH 61	LH 35BL	Childrens Brief 200mm - Black
LH 60	LH 34BL	Ladies swimwear 250mm - Black
SPECIALITY HANGERS		
FR 13	FR 78	Infants Frame Hanger 250x320mm
FR 14	FR 79	Infants Frame Hanger 250x350mm
NEW	FR 80	Childrens Frame Hanger 350x430mm
TH 40D	TH 40D	Multi Set 250mm
TH 42D	TH 42D	Multi Set 350mm
NEW	TP 90	2 Prong Hanger - 210mm
NEW	TP 91	3 Prong Hanger - 210mm
FASHION ACCESSORIES		
SC 27	SC 27	Small Scarf 35mm
SC 70	SC 70	130 x 170mm Round Scarf
SC 71	SC 71	Shawl Hanger 225mm
SC 29	SC 29	Shawl Hanger 300mm
AC 30	AC 30	Gun Hook
BH 38	BH 38	Belt Hanger 170mm
WL 63	WL 63	Wallet Hanger 110mm
FOOTWEAR HANGERS		
FW 24	FW 24	Thong Hanger 115mm
FW 25	FW 25	Multi Purpose Hanger 170mm
FW 77	FW 77	Multi Purpose Hanger 195mm
FW 23	FW 23	U End Hanger 70mm
FW 75	FW 75	U End Hanger 120mm
FW 78	FW 78	Boot Hanger 180mm
NEW	FWGN 1	TBA
ACCESSORIES		
AC 17	AC67	Foam Sleeves per pair
AC 5	AC 65	Hook and Loop
NEW	AC 80	Brand Plates for Garments
NEW	AC 82	Brand Plates for Lingerie
SIZING		
AC 16	AC 16	Garment Sizing Clip
NEW	AC 14	Metal Hook Sizing Clip
AC 23	AC 22	Lingerie Size Tabs
AC 21	AC 21	Footwear Size Tabs

C O D E

TH40

TH41

TH42

Top Hanger

Category • Children, Youth

Application • Shirts, Tops (assorted), Dresses, Knitwear, Jackets, Jump Suits, Overalls, Sleepwear, Spencers, Camisoles and Slips

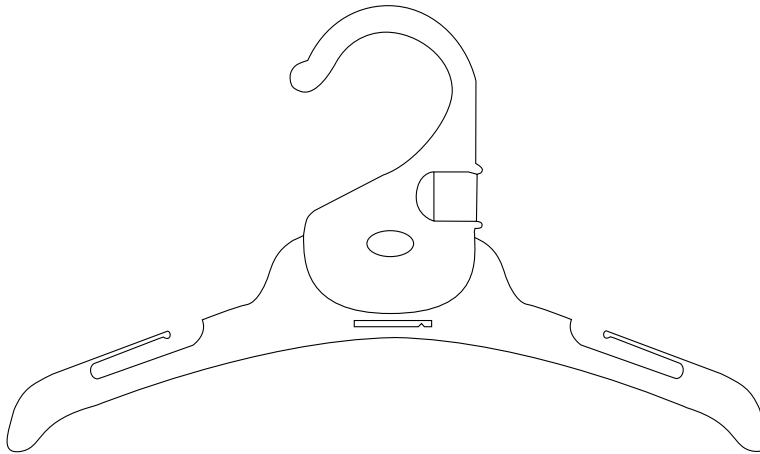

TH40
250mm

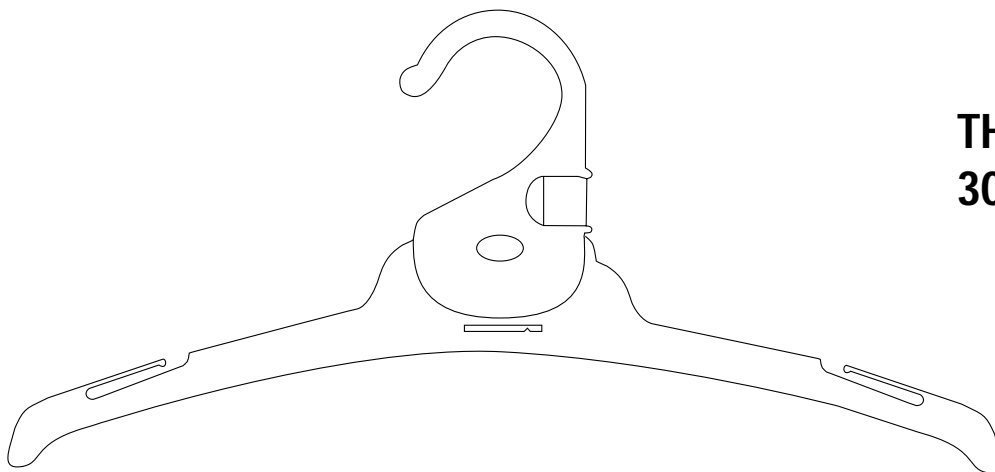

TH41
300mm

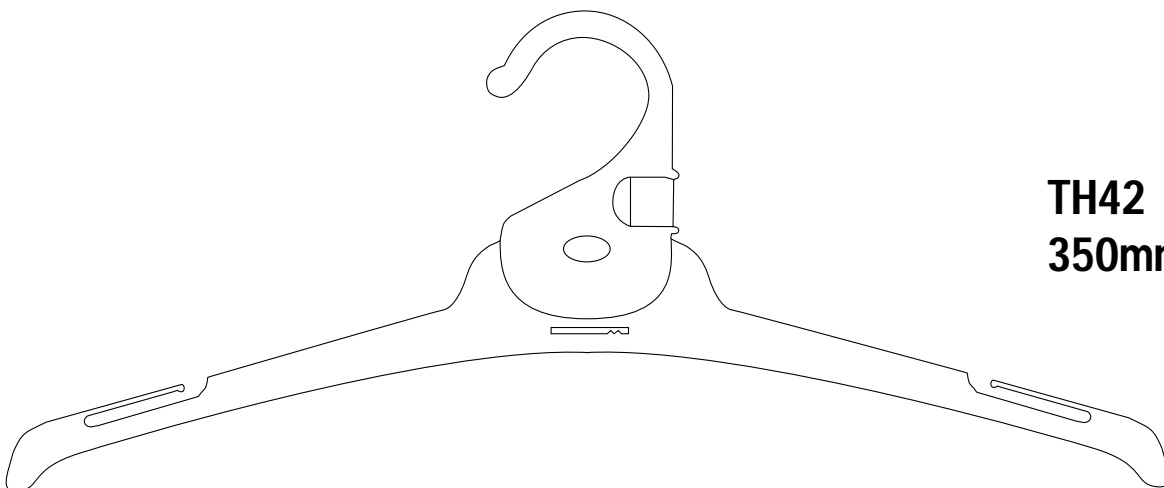

TH42
350mm

C O D E

TH43

TH45

TH46

Top Hanger

Category • Children, Adult

Application • Shirts, Tops (assorted), Dresses, Lightweight Jackets, Pyjamas, Dressing Gowns, Spencers and Vests

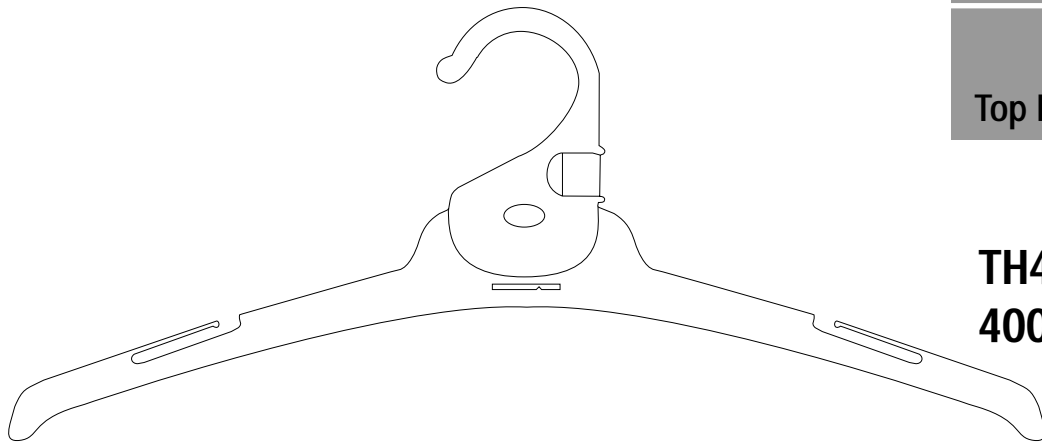

TH43
400mm

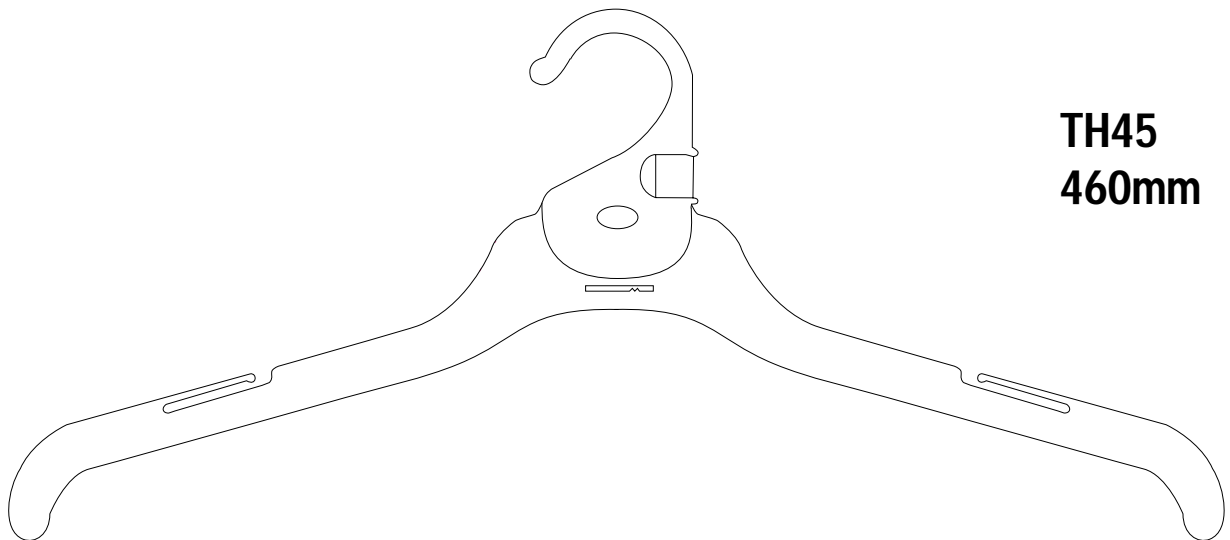

TH45
460mm

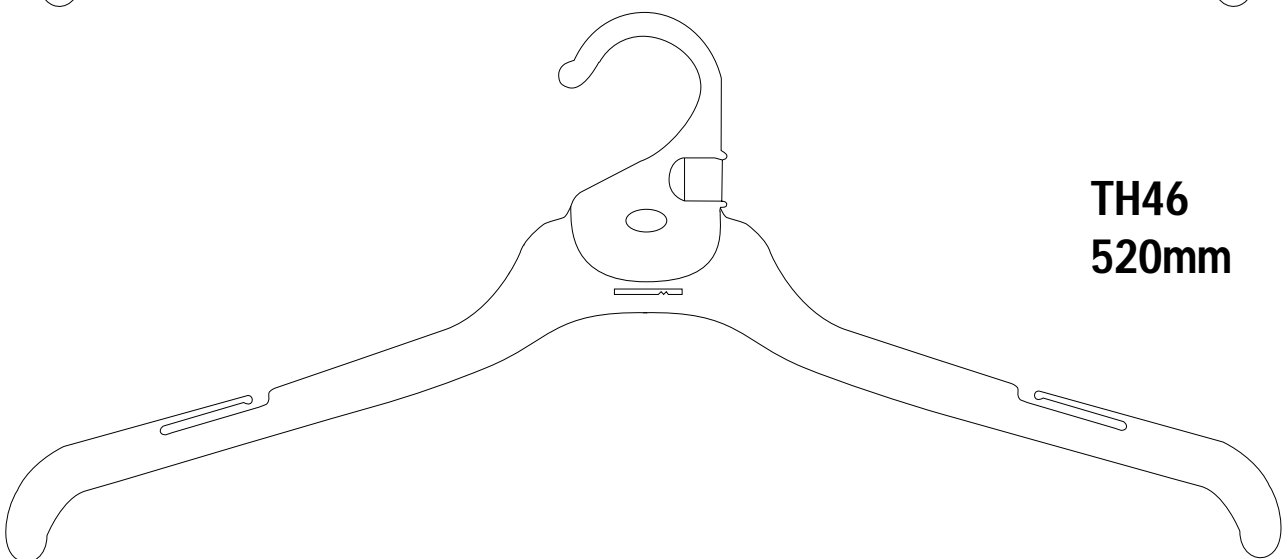

TH46
520mm

C O D E

KN44

KN47

**Knitwear
Hanger**

Category • Adult / Youth

Application • Knitwear, Lightweight Jackets, Coats, Parkas
and Maternity Wear

KN44
420mm

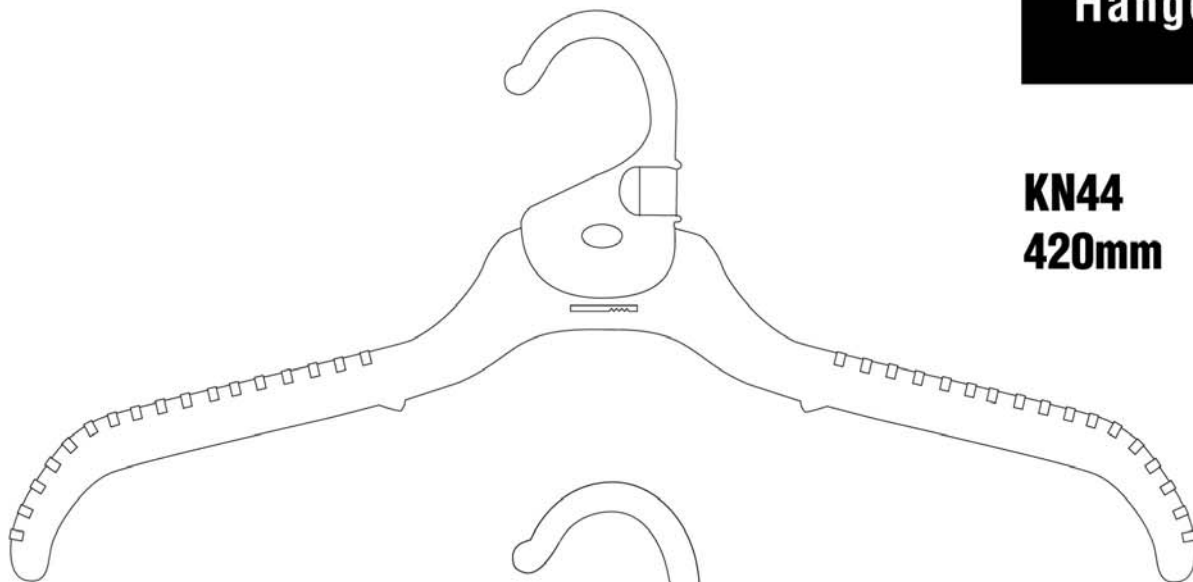

KN47
460mm

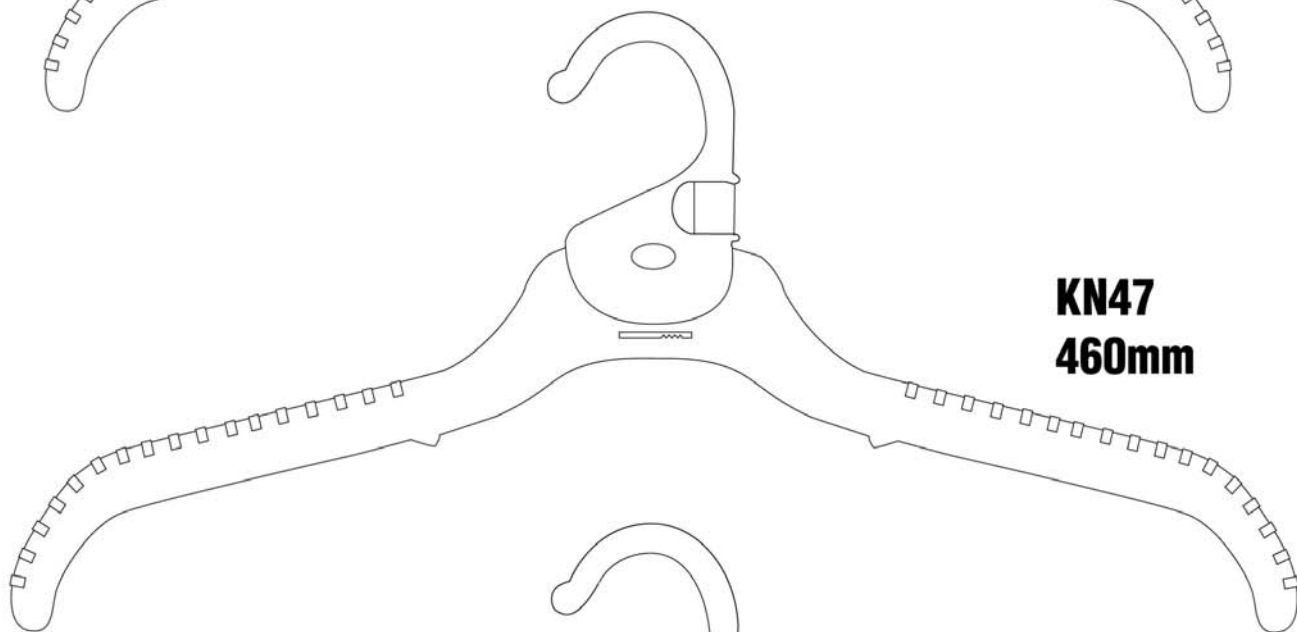

KN44 / AC67
KN47 / AC67

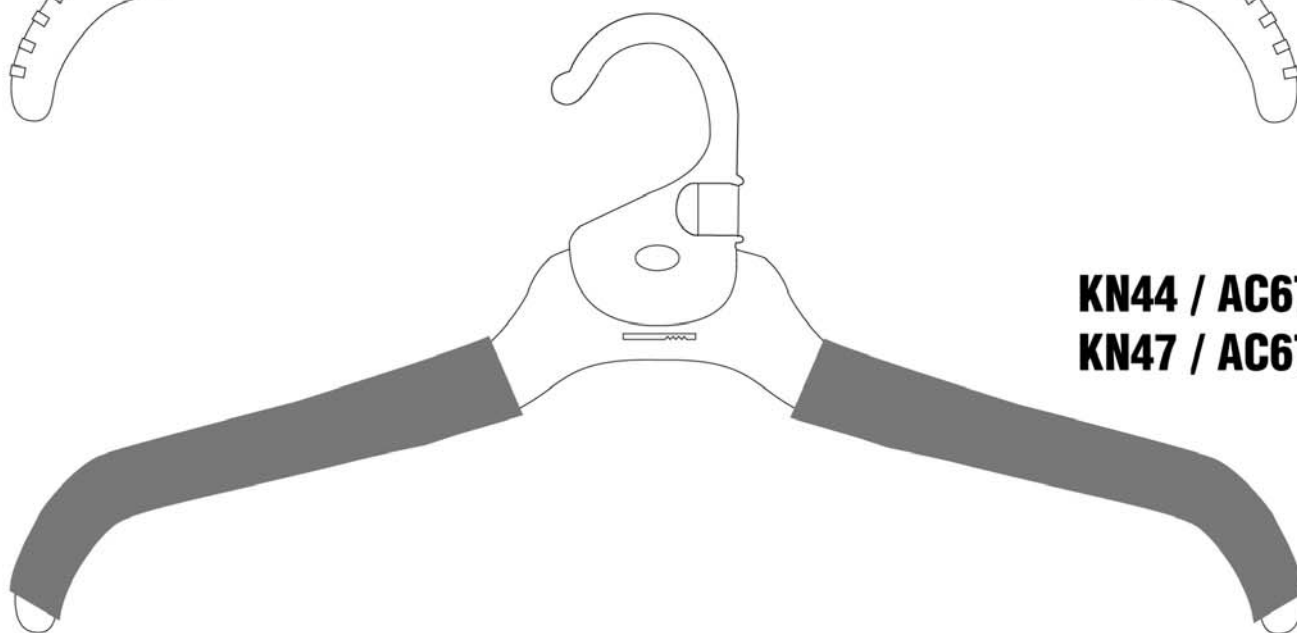

C O D E

SU86

Category • Adult

Application • Jackets

**460mm
Jacket Hanger**

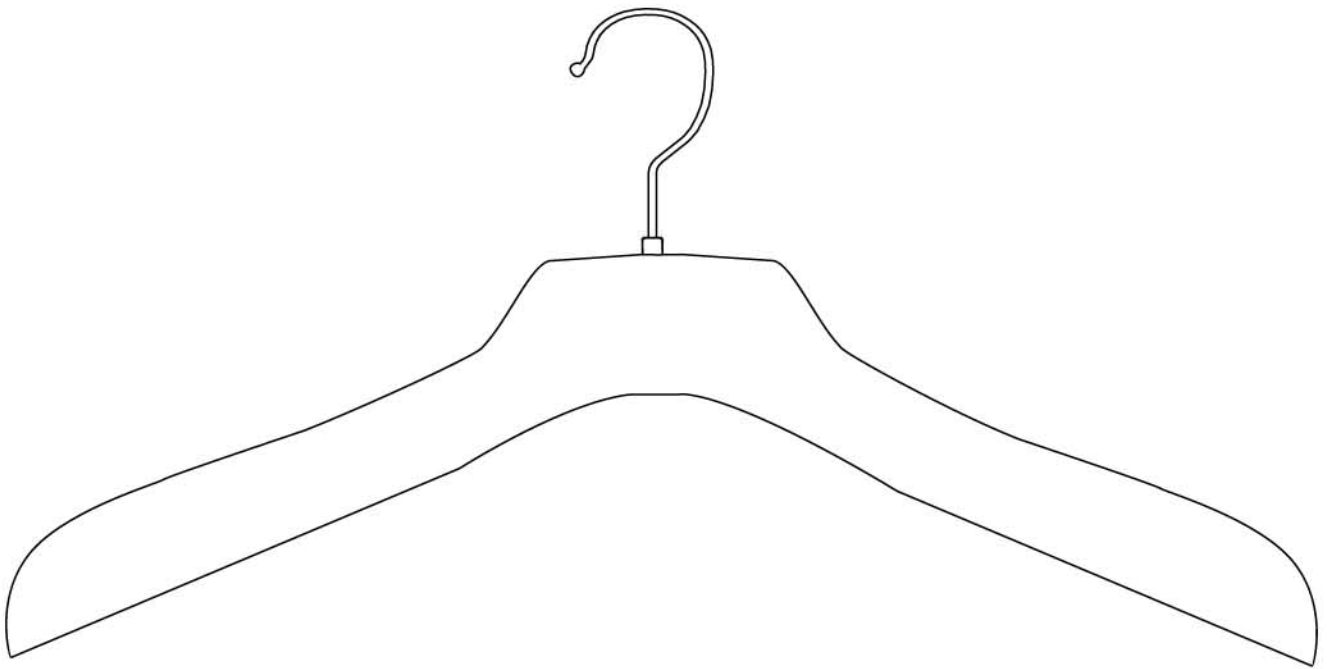

C O D E

AC67

Category • Adult

Application • For KN44 and KN47 Knitwear Hanger only

**Foam Sleeve
(Knitwear
Hanger)**

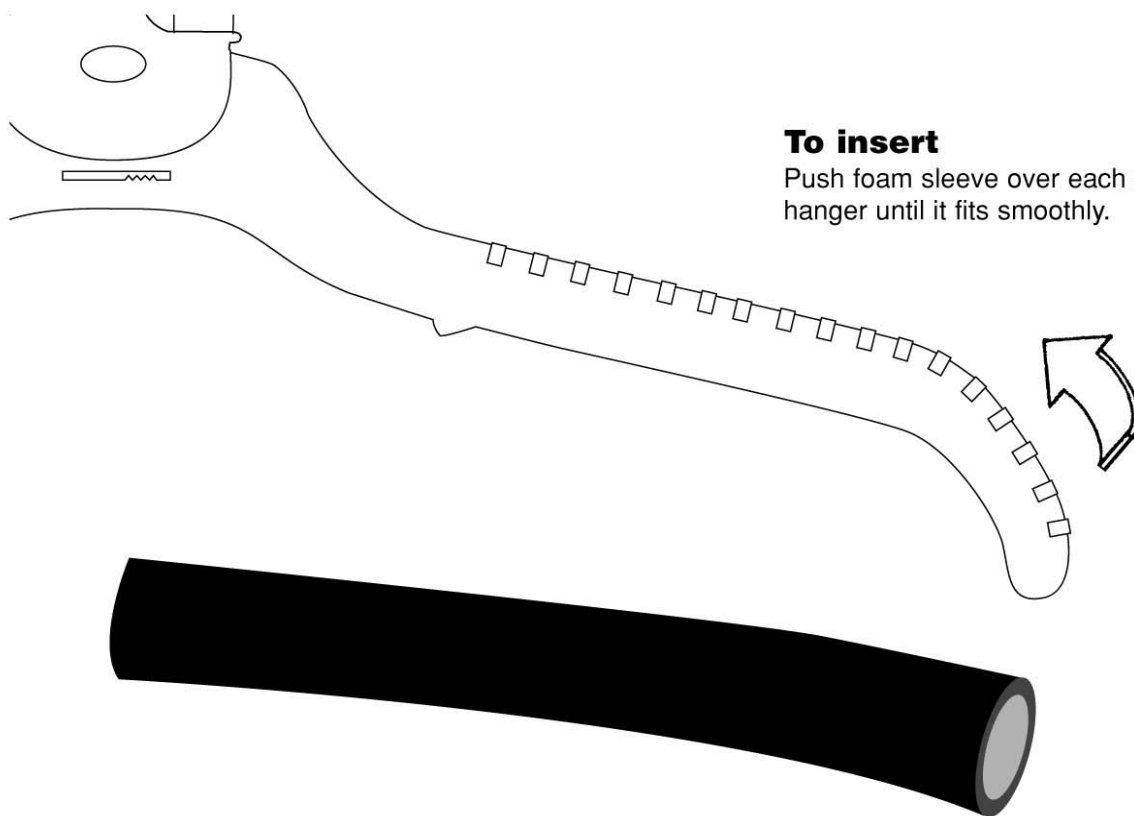

To insert

Push foam sleeve over each side of hanger until it fits smoothly.

FR78

FR79

FR80

Frame Hanger

Category • Infant and Toddlers

Application • 2 Piece sets

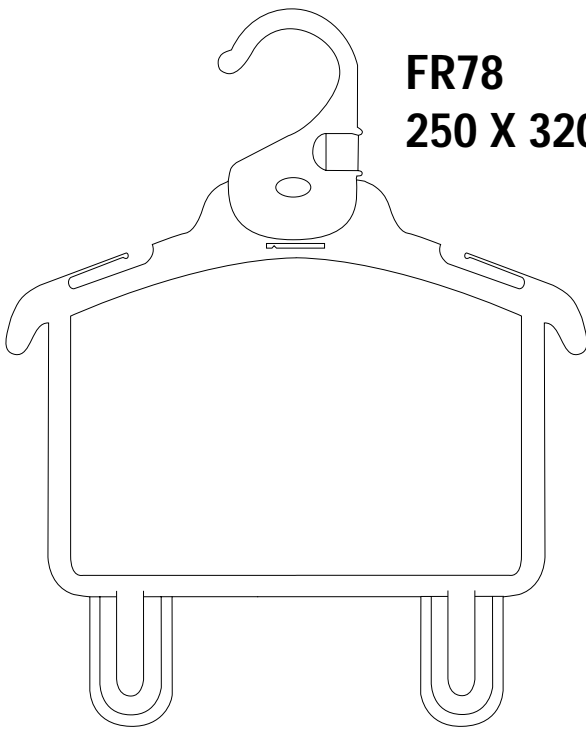

FR78
250 X 320mm

FR79
250 X 350mm

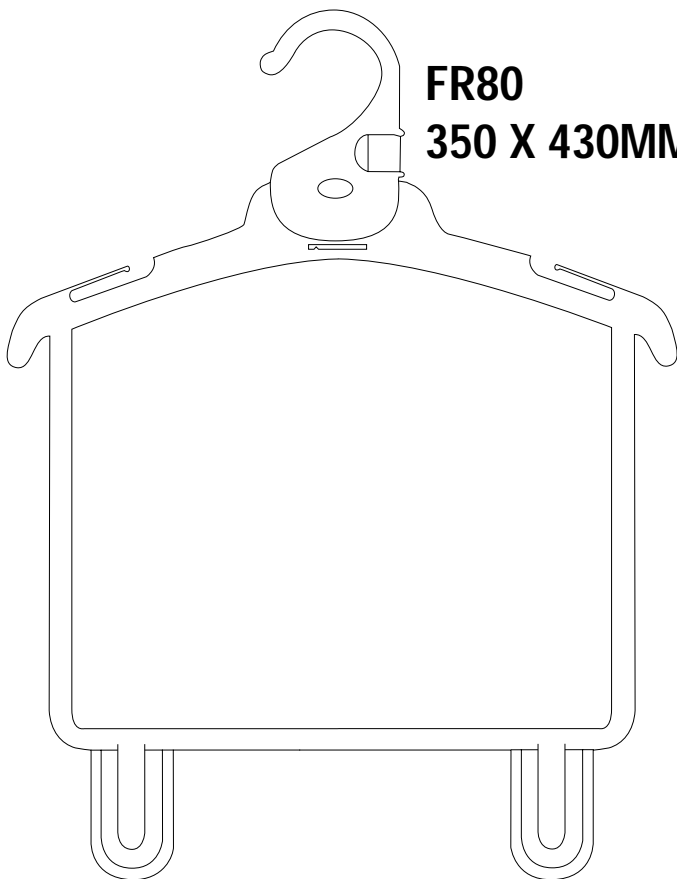
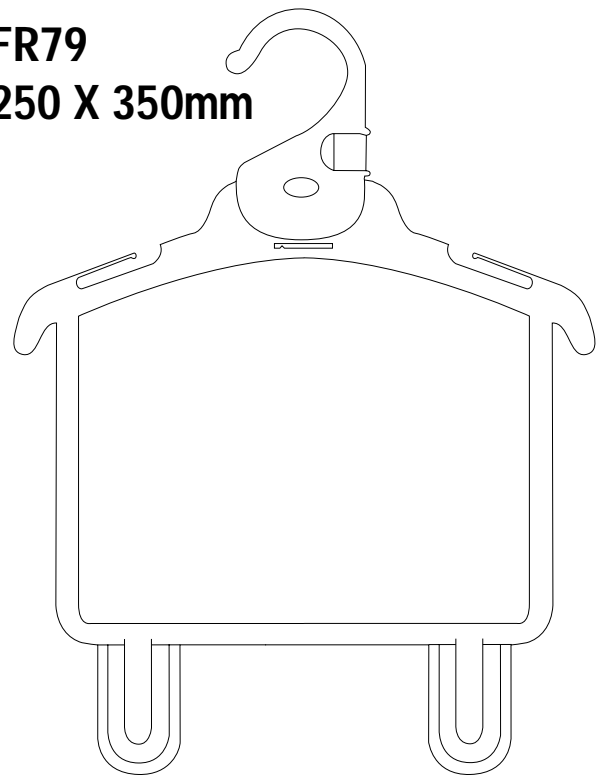

FR80
350 X 430MM

C O D E

TH42D

**350mm x
260mm**

Category • Toddlers, Youths

Application • Multi sets

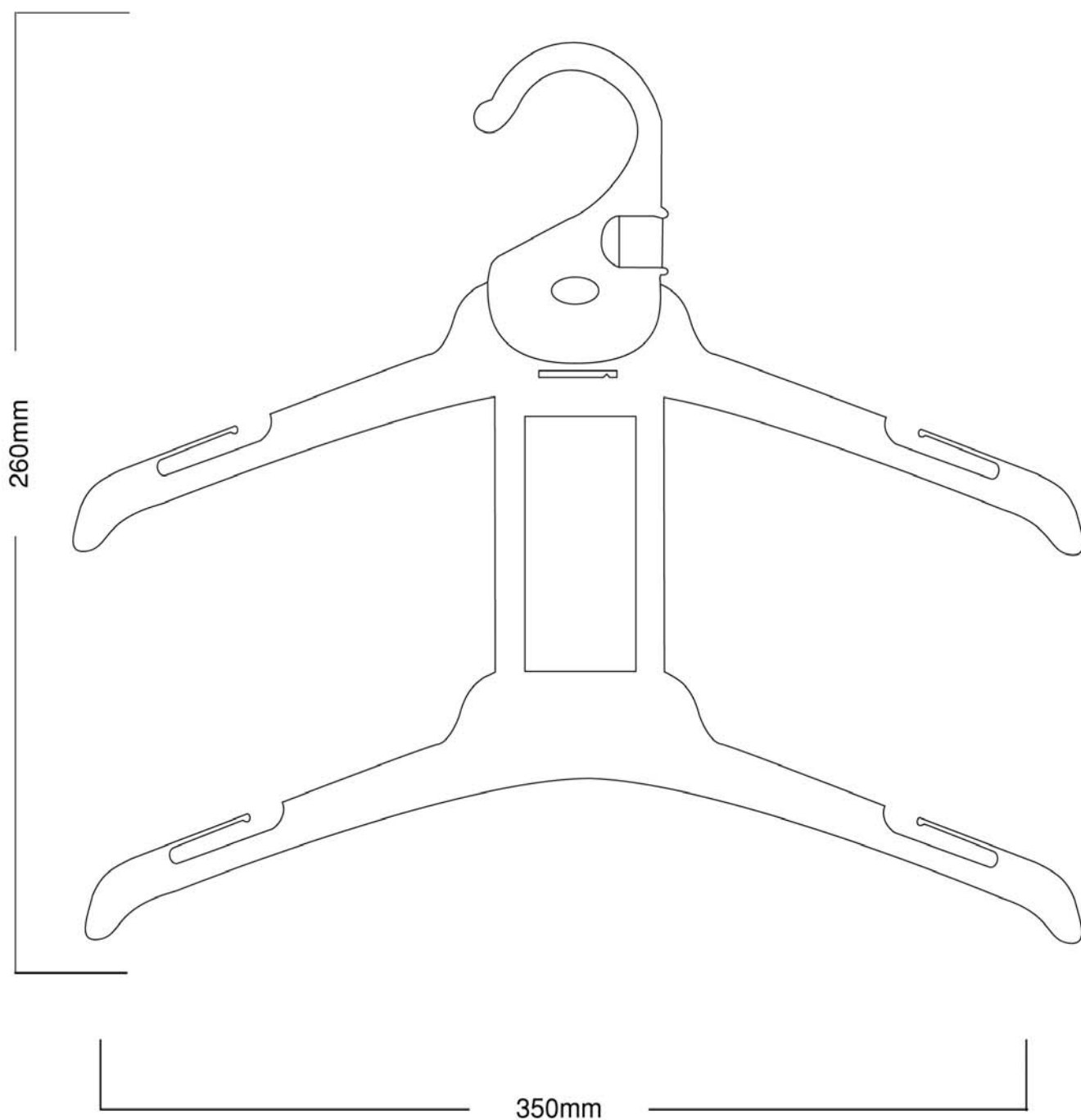

C O D E

Category • Menswear

Application • Multi Garments / Sets

TH45D

**280mm x
460mm**

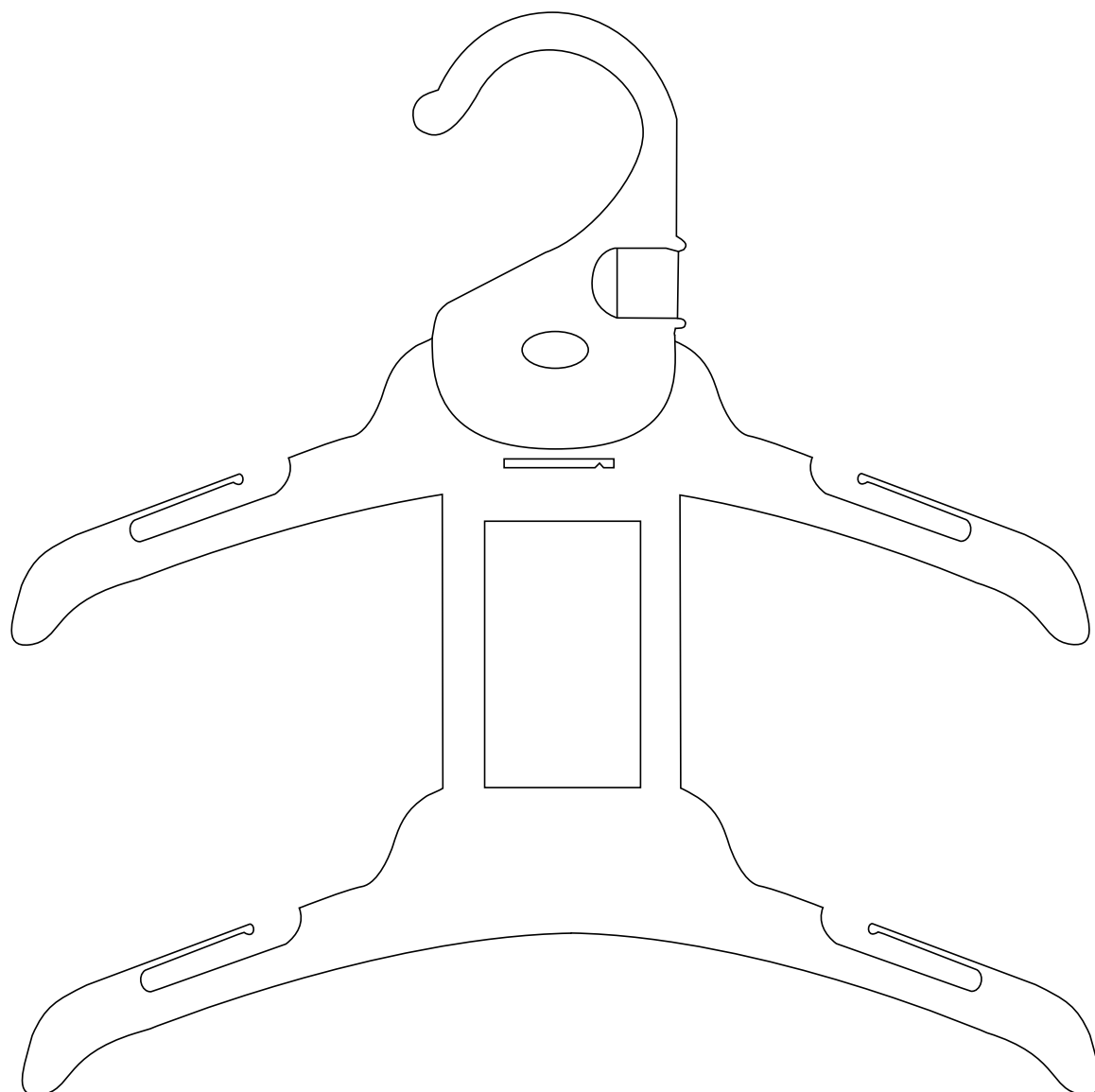

C O D E

TP90

TP91

Multi
Garments

Category • Infantswear

Application • Sleepsuits, Rompers, 2 Piece Sets

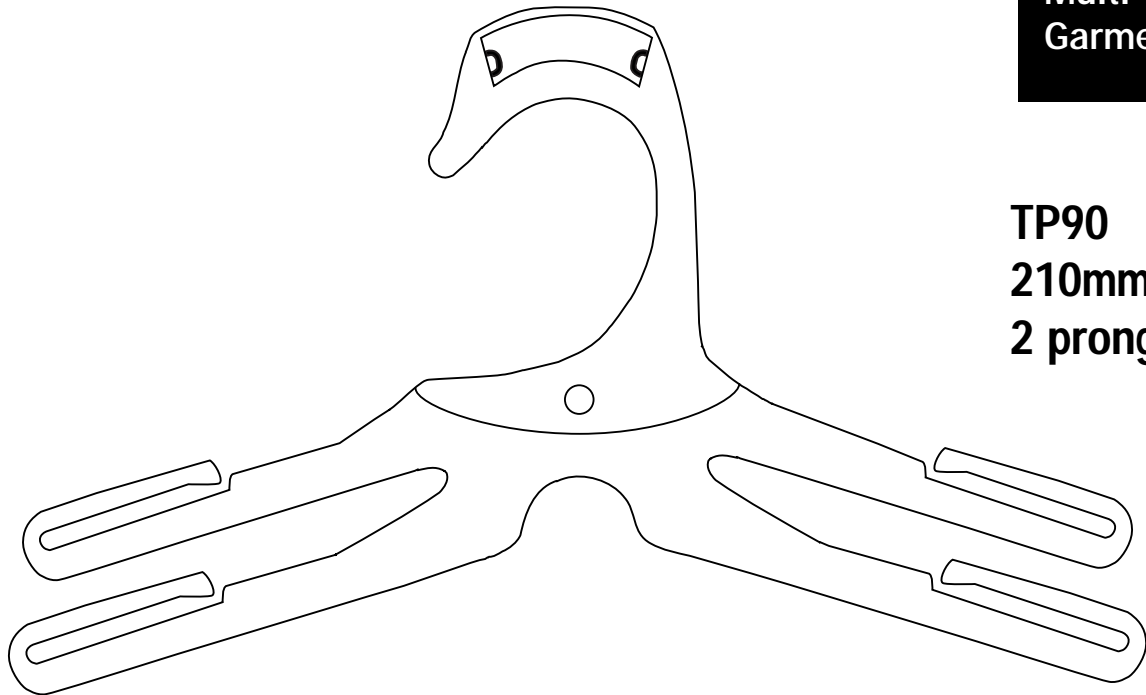

TP90
210mm
2 prong

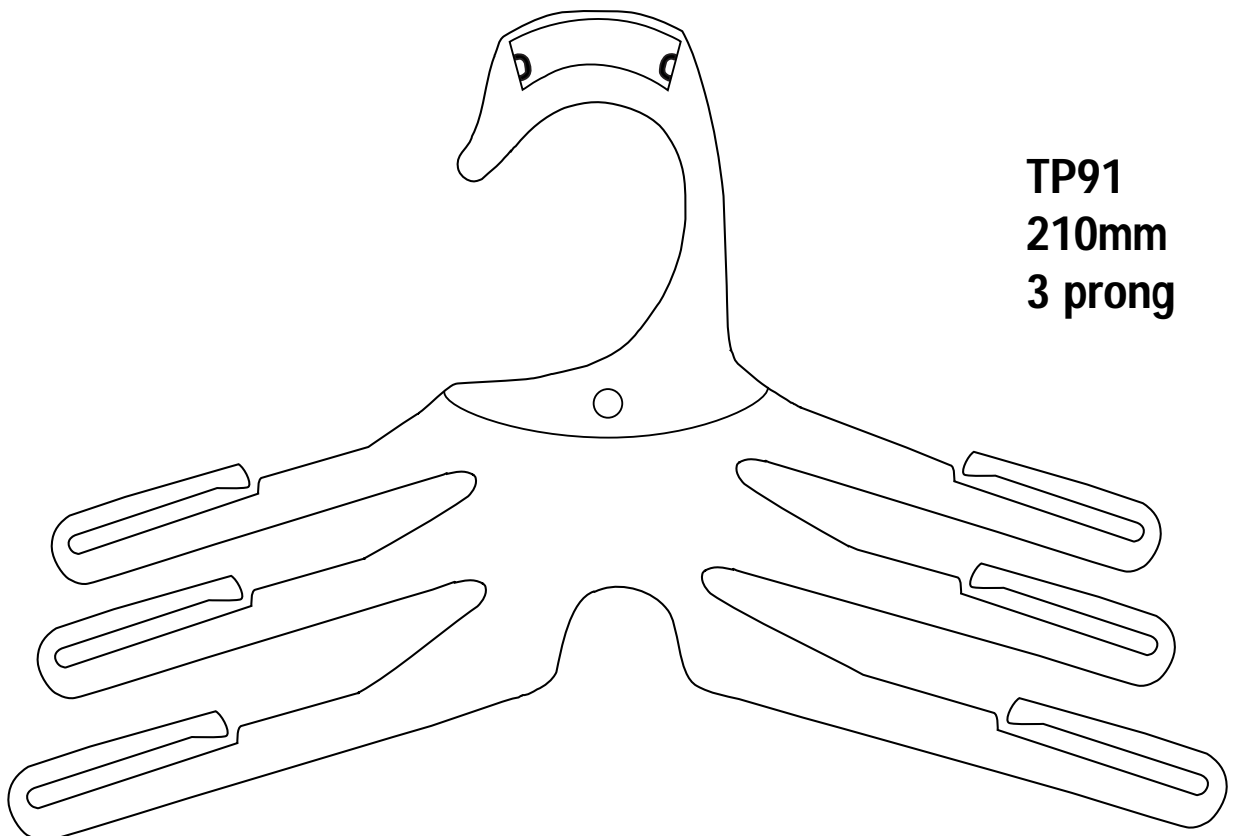

TP91
210mm
3 prong

C O D E

BH60

Category • Children, Adult

Application • Pants, Skirts, Shorts and Sets

BH61

Bottom
Hanger
- Low Profile

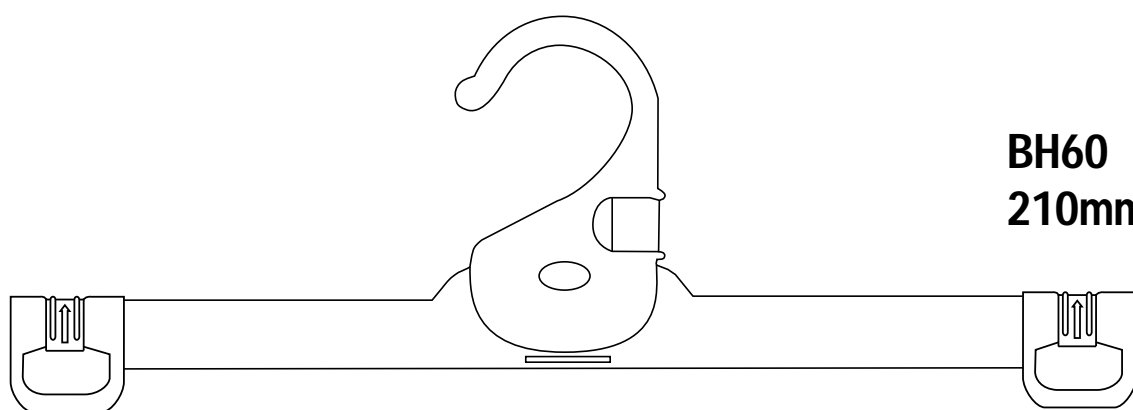

BH60
210mm

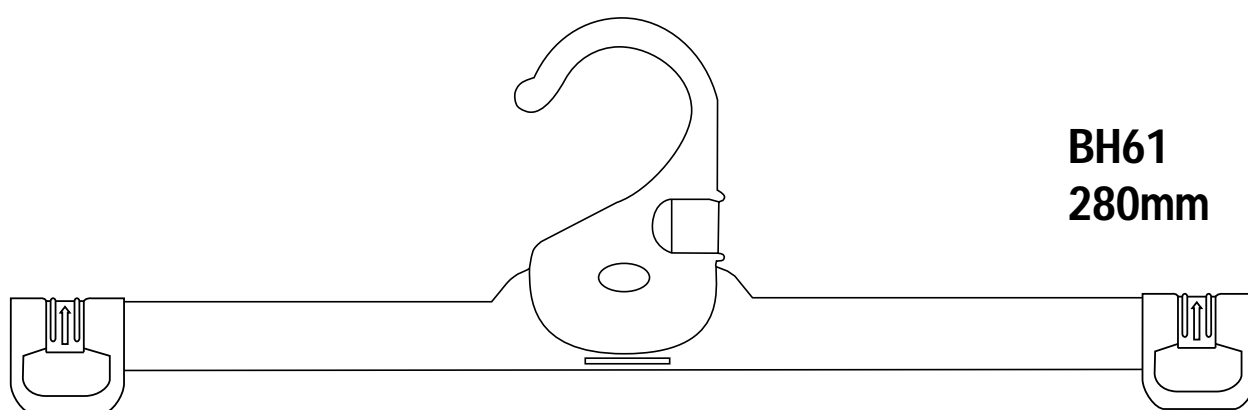

BH61
280mm

C O D E

BH62

BH63

Bottom
Hanger
- Low Profile

Category • Adult

Application • Pants, Skirts, Shorts, etc

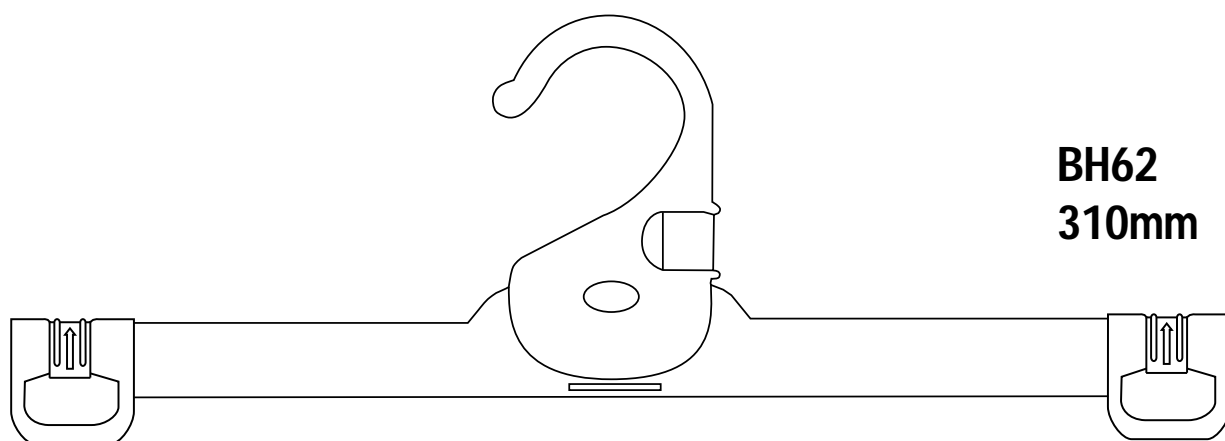

BH62
310mm

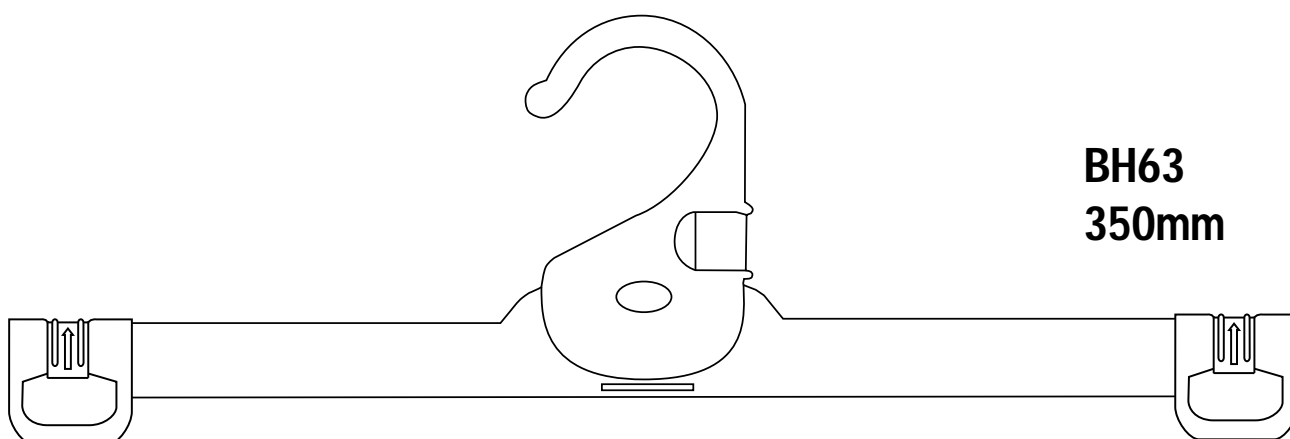

BH63
350mm

C O D E

PH54

Category • Children, Adult

Application • Pants, Skirts, Shorts, and Sets

PH55

**Bottom
Hanger
- Prong**

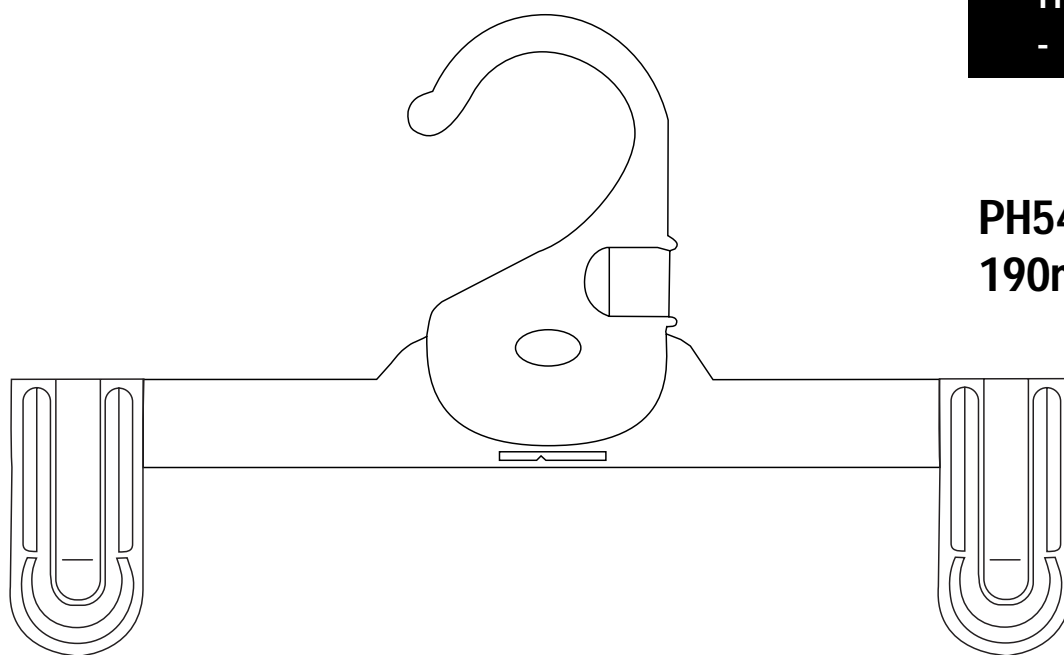

**PH54
190mm**

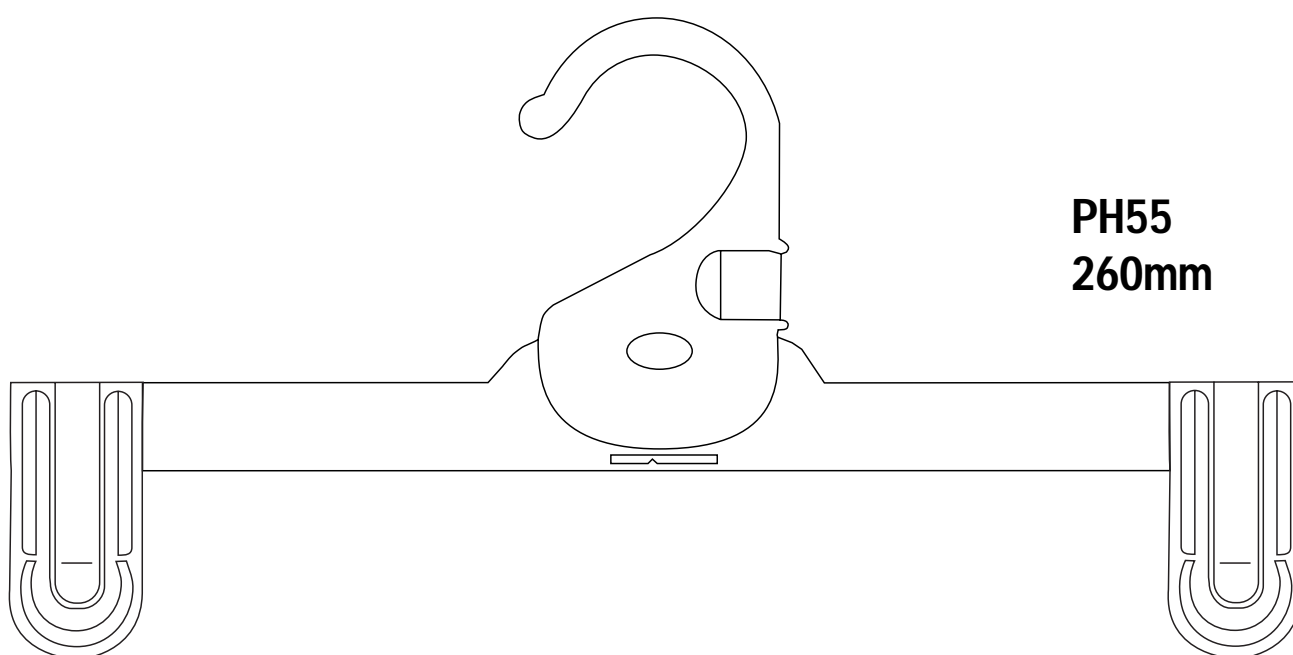

**PH55
260mm**

C O D E

BSL82

Category • Adult

Application • Pants, Shorts and Skirts
Fabrics - Velours, Stins, Corduroy etc..

**Adult
Soft Lock
Padded Hanger**

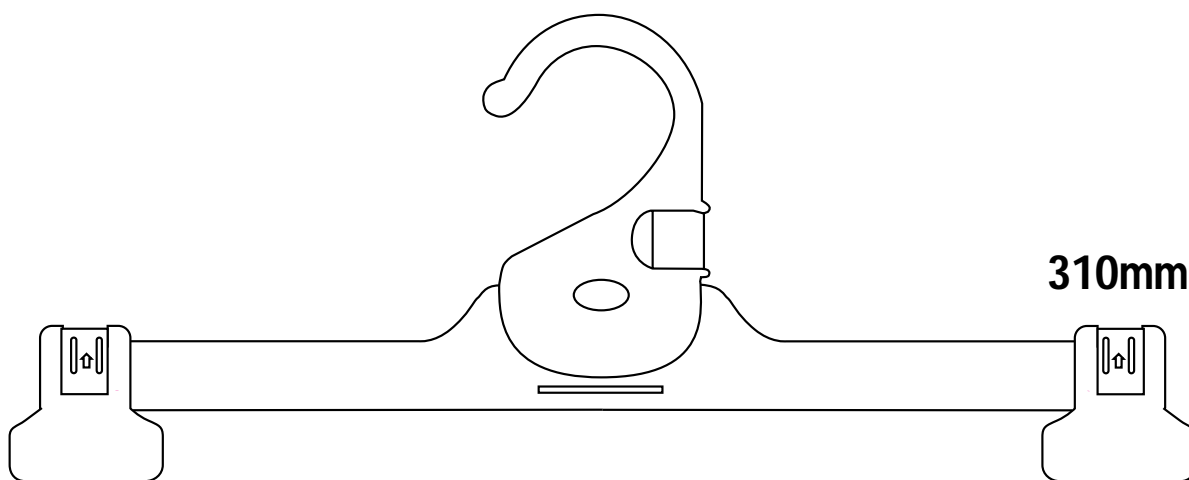

310mm

C O D E

BH97

BH99

**Trouser
Hanger**

Category • Childrens and Adults

Application • Trousers

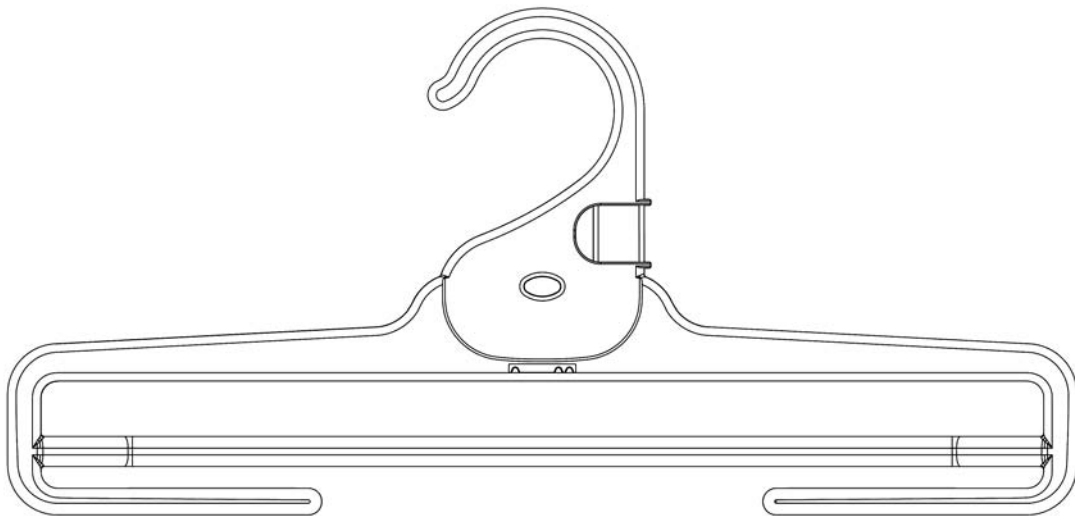

BH97
320mm

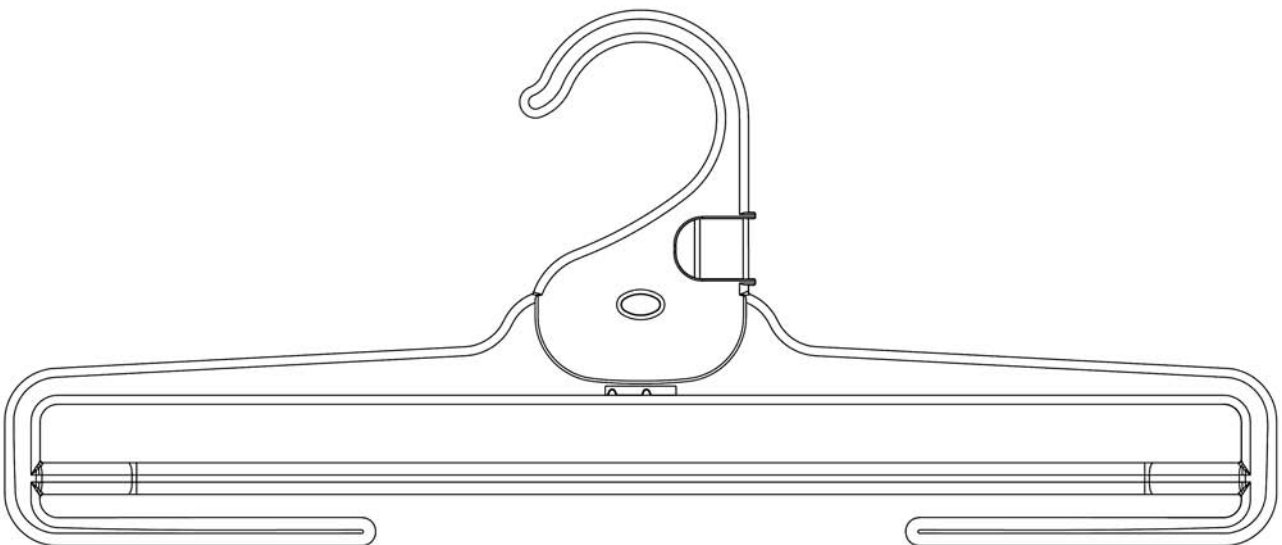

BH99
360mm

C O D E

Category • Infants, Toddlers

Application • Leggings

LH94

180mm

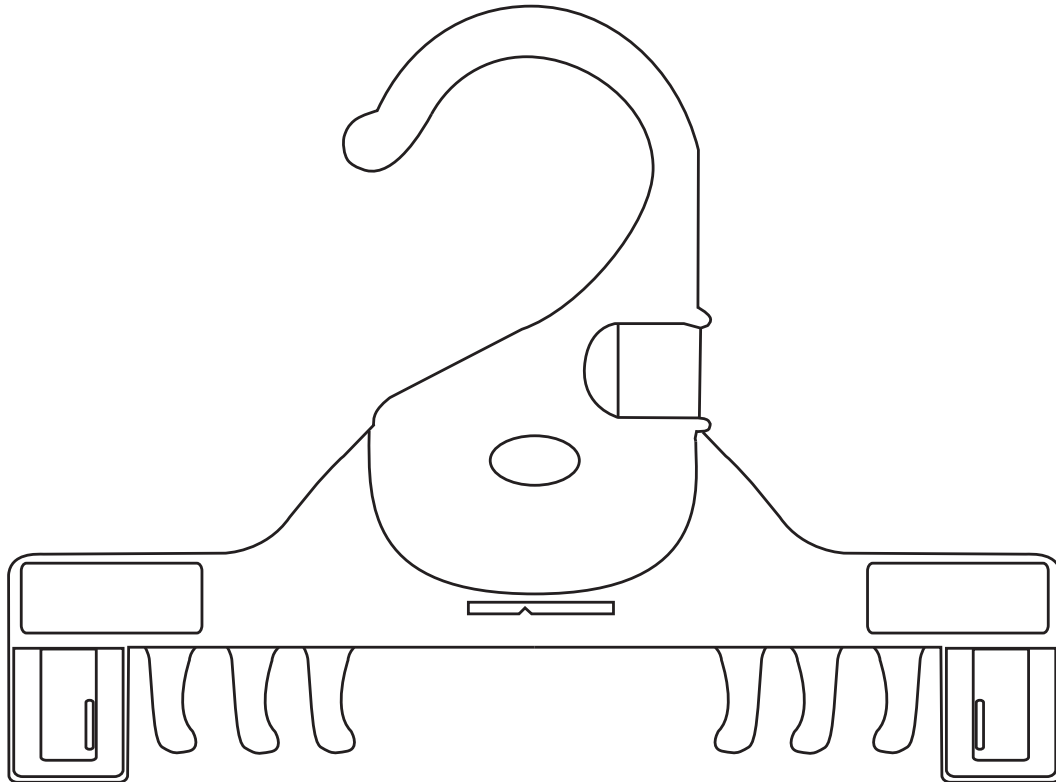

C O D E

AC16

Category • All

Application • All general purpose hangers
for outerwear and sleepwear

Size Clips



actual size

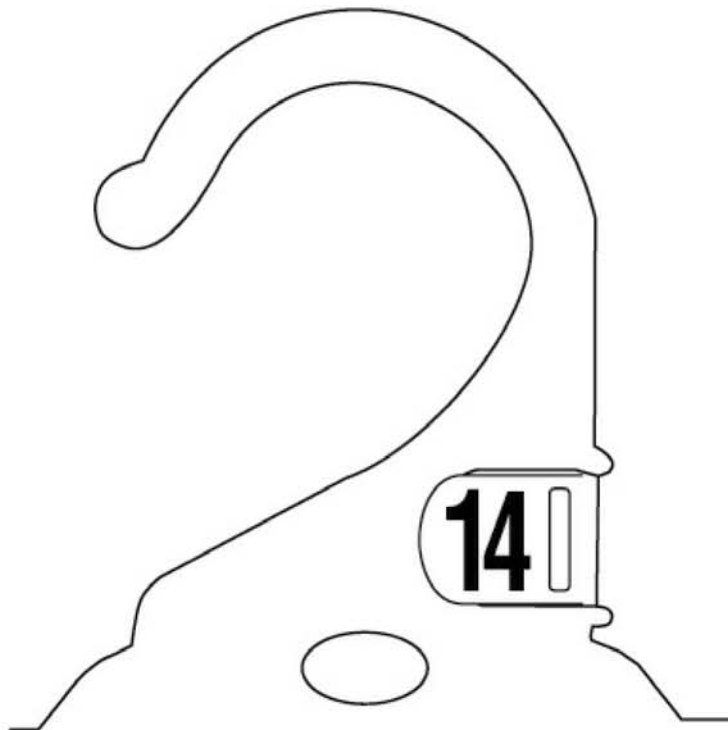

BIG W AC16 SIZE CLIP CHART

Outwear Hangers Only

CHILDRENSWEAR

SIZE	PMS	COLOUR
00000	396	Lime
0000	318	Turquoise
000	347	Dark Green
00	164	Orange
0	264	Lilac
1	185	Red
2	121	Yellow
3	230	Pink
4	359	Pale Green
5	154	Tan Brown
6	264	Lilac
7	444	Grey
8	185	Red
10	279	Dark Blue
12	347	Dark Green
14	318	Turquoise
16	154	Tan Brown
20	121	Yellow
22	359	Pale Green
6/8	185	Red
8/10	279	Dark Blue
12/14	318	Turquoise
S	347	Dark Green
M	185	Red
L	PB	Proc Blue

LADIESWEAR

SIZE	PMS	COLOUR
8	359	Pale Green
10	154	Tan Brown
12	185	Red
14	279	Dark Blue
16	264	Lilac
18	121	Yellow
20	347	Dark Green
22	444	Grey
24	164	Orange
26	230	Pink
8/10	154	Tan Brown
10/12	185	Red
12/14	279	Dark Blue
14/16	264	Lilac
16/18	121	Yellow
18/20	347	Dark Green
18/22	444	Grey
20/22	444	Grey
22/24	164	Orange
24/26	230	Pink
10/16	264	Lilac
S	347	Dark Green
M	185	Red
L	PB	Proc Blue
XL	157	Brown
XS	318	Turquoise
OSFA	WHT	White

MENSWEAR

SIZE	PMS	COLOUR
72	264	Lilac
74	264	Lilac
77	318	Turquoise
79	165	Orange
82	347	Dark Green
84	279	Dark Blue
87	185	Red
87R	185	Red
87S	185	Red
92	PB	Proc Blue
92R	PB	Proc Blue
92S	PB	Proc Blue
97	157	Brown
97R	157	Brown
97S	157	Brown
102	375	Bright Green
102S	375	Bright Green
107	121	Yellow
107S	121	Yellow
112	154	Tan Brown
117	150	Light Orange
122	BLK	Black
127	444	Grey
132	MAG	Magenta
75	318	Turquoise
80	347	Dark Green
85	185	Red
90	PB	Proc Blue
95	157	Brown
100	375	Bright Green
105	157	Brown
110	154	Tan Brown
115	121	Yellow
120	154	Tan Brown
125	150	Light Orange
130	BLK	Black
3XL	121	Yellow
4XL	154	Tan Brown
5XL	150	Light Orange
6XL	BLK	Black
S	347	Dark Green
M	185	Red
L	PB	Proc Blue
XL	157	Brown
XXL	375	Bright Green
XS	318	Turquoise
OSFA	WHT	White
44	154	Tan Brown
46	150	Light Orange
48	BLK	Black
50	444	Grey

Category • Adults

Application • Metal Hook Hangers

C O D E

AC18

Size Clip



BIG W AC18 SIZE CLIP CHART

Outerwear Hangers Only

ADULTS

SIZE	PMS	COLOUR
8	359	Pale Green
10	154	Tan Brown
12	185	Red
14	279	Dark Blue
16	264	Lilac
18	121	Yellow
20	347	Dark Green
22	444	Grey
24	164	Orange
26	230	Pink
12-14	279	Dark Blue
16-18	121	Yellow
20-22	444	Grey
24-26	230	Pink
XS	318	Turquoise
S	347	Dark Green
M	185	Red
L	PB	Proc Blue
XL	157	Brown
XXL	375	Bright Green

C O D E

BR32

Category • Womens

Application • Bra's

**285mm
Bra Hanger**

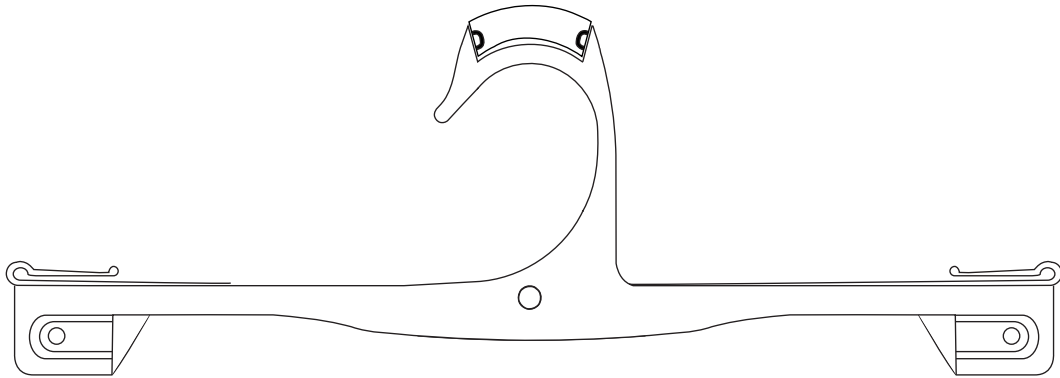

• BR32CR = CRYSTAL

C O D E

LH35

LH34

**Brief
Hanger**

Category • Childrens & Adult

Application • Briefs and Bras
(Black = Swimwear and Activewear)

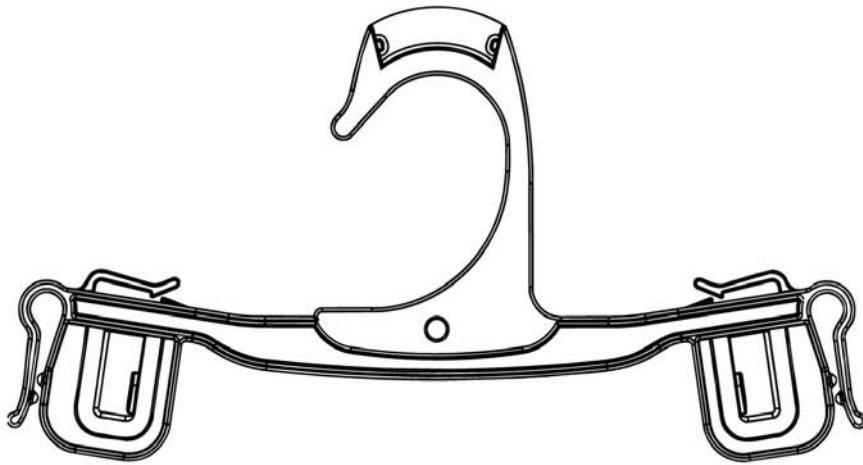

LH35
200mm

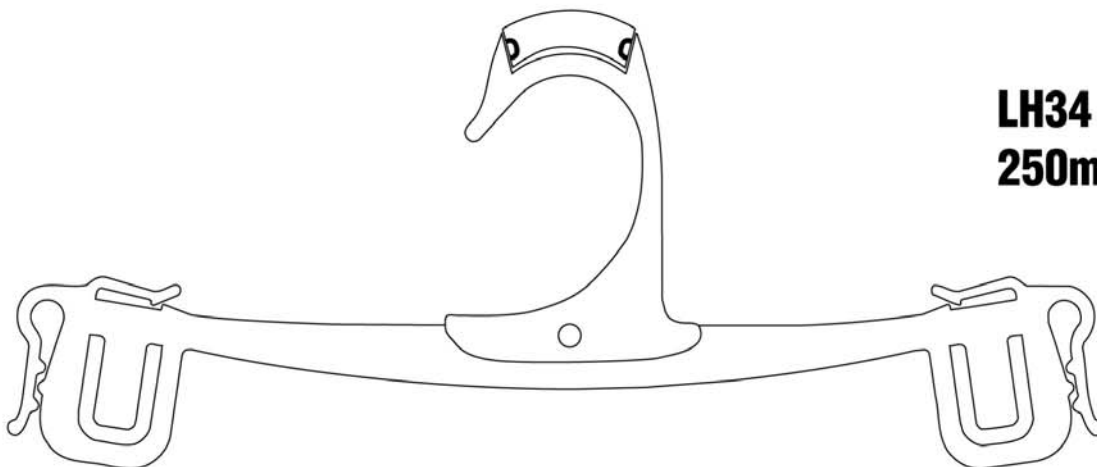

LH34
250mm

C O D E

AC22

Category • All

Application • Colour coded size inserts
for underwear and lingerie hangers

**Lingerie
Sizing
Insert**

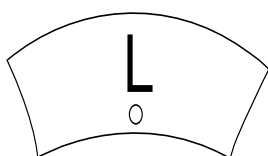

actual size

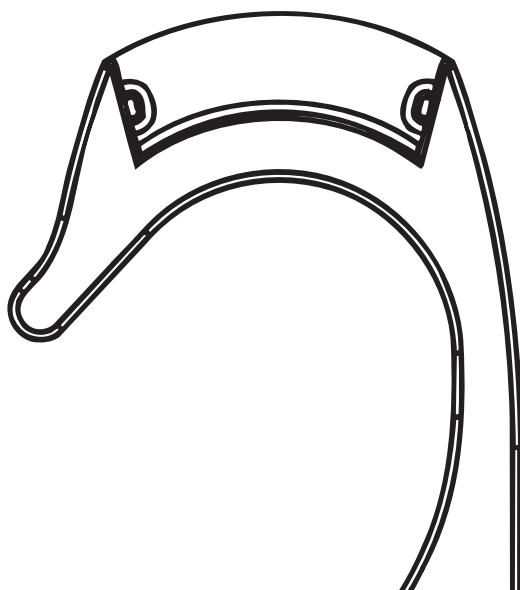

BIG W AC22 SIZE TAB CHART

Lingerie Hangers Only

LADIESWEAR

SIZE	PMS	COLOUR
8	359	Pale Green
10	154	Tan Brown
12	185	Red
14	279	Dark Blue
16	264	Lilac
18	121	Yellow
20	347	Dark Green
22	444	Grey
24	164	Orange
26	230	Pink
8/10	154	Tan Brown
10/12	185	Red
12/14	279	Dark Blue
14/16	264	Lilac
16/18	121	Yellow
18/20	347	Dark Green
20/22	444	Grey
22/24	164	Orange
24/26	230	Pink
8A	359	Pale Green
8AA	359	Pale Green
8AAA	359	Pale Green
10AA	154	Tan Brown
10A	154	Tan Brown
10B	154	Tan Brown
10C	154	Tan Brown
10D	154	Tan Brown
10DD	154	Tan Brown
12AA	185	Red
12A	185	Red
12B	185	Red
12C	185	Red
12D	185	Red
12DD	185	Red
12E	185	Red
14A	279	Dark Blue
14B	279	Dark Blue
14C	279	Dark Blue
14D	279	Dark Blue
14DD	279	Dark Blue
14E	279	Dark Blue
16B	264	Lilac
16C	264	Lilac
16D	264	Lilac
16DD	264	Lilac
16E	264	Lilac
18B	121	Yellow
18C	121	Yellow

LADIESWEAR cont....

SIZE	PMS	COLOUR
18D	121	Yellow
18DD	121	yellow
18E	121	yellow
20B	347	Dark Green
20C	347	Dark Green
20D	347	Dark Green
20DD	347	Dark Green
20E	347	Dark Green
22C	444	Grey
22D	444	Grey
22DD	444	Grey
24C	164	Orange
24D	164	Orange
24DD	164	Orange
24E	164	Orange

MENSWEAR

SIZE	PMS	COLOUR
75/80	347	Dark Green
85/90	PB	Proc Blue
95/100	375	Bright Green
105/110	154	Tan Brown
S	347	Dark Green
M	185	Red
L	PB	Proc Blue
XL	157	Brown
XXL	375	Bright Green
3XL	121	Yellow

CHILDRENSWEAR

SIZE	PMS	COLOUR
2/3	230	Pink
3/4	359	Pale Green
4/6	264	Lilac
6/8	185	Red
8/10	279	Dark Blue
10/12	347	Dark Green
12/14	318	Turquoise
0	264	Lilac
1	185	Red
2	121	Yellow
3	230	Pink
4	359	Pale Green
5	154	Tan Brown
6	264	Lilac
7	444	Grey
8	185	Red
10	279	Dark Blue
12	347	Dark Green
14	318	Turquoise
16	154	Tan Brown

C O D E

FW24

Category • All

Application • Thongs

115 mm

Thong
Hanger

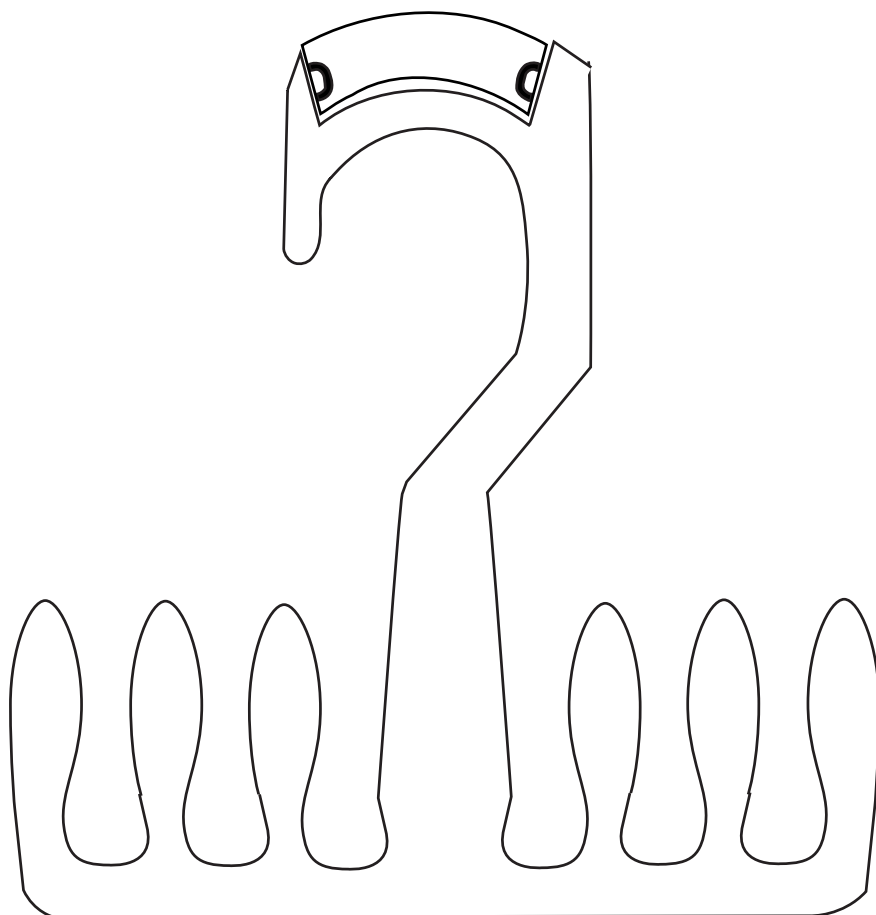

C O D E

FW23

FW75

Childrens
U End
Hanger

Category • Children, Adult

Application • Casual, Canvas
and Court Shoes

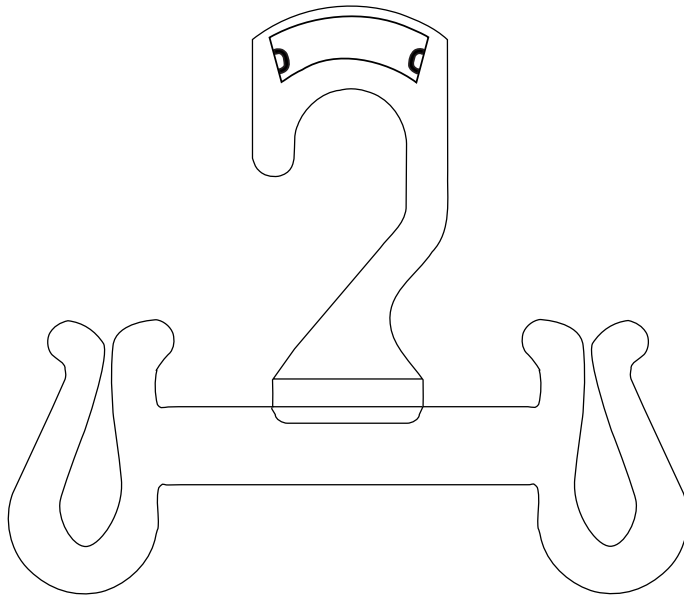

FW23
70mm

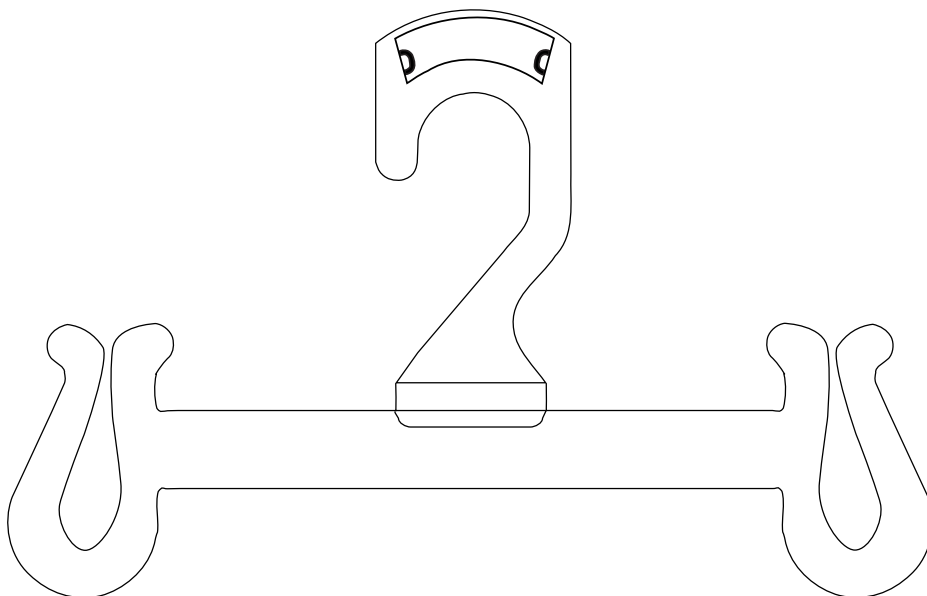

FW75
120mm

C O D E

Category • All

Application • Shoes, Slippers and Scuffs

FW25

FW77

Multi
Purpose
Shoe Hanger

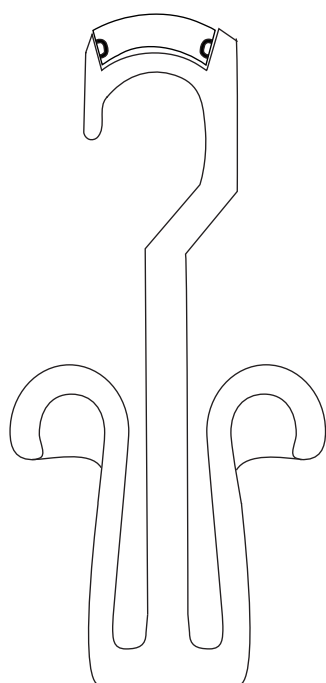

FW25

170mm

*Not available
in Australia

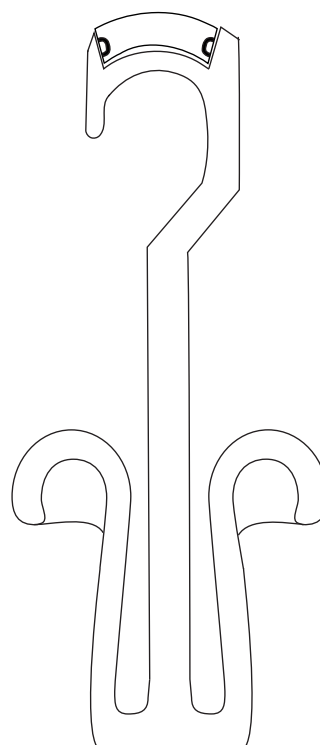

FW77

195mm

*Not available
in Australia

C O D E

FW101

FW102

FW103

**Goose Neck
Hanger**

Category • All

Application • Shoes, Slippers and Scuffs

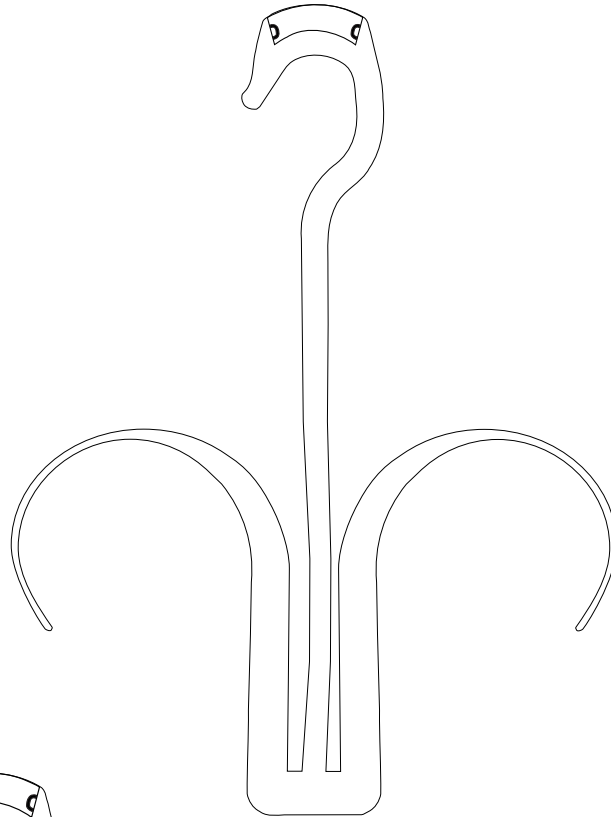

**FW101
170mm**

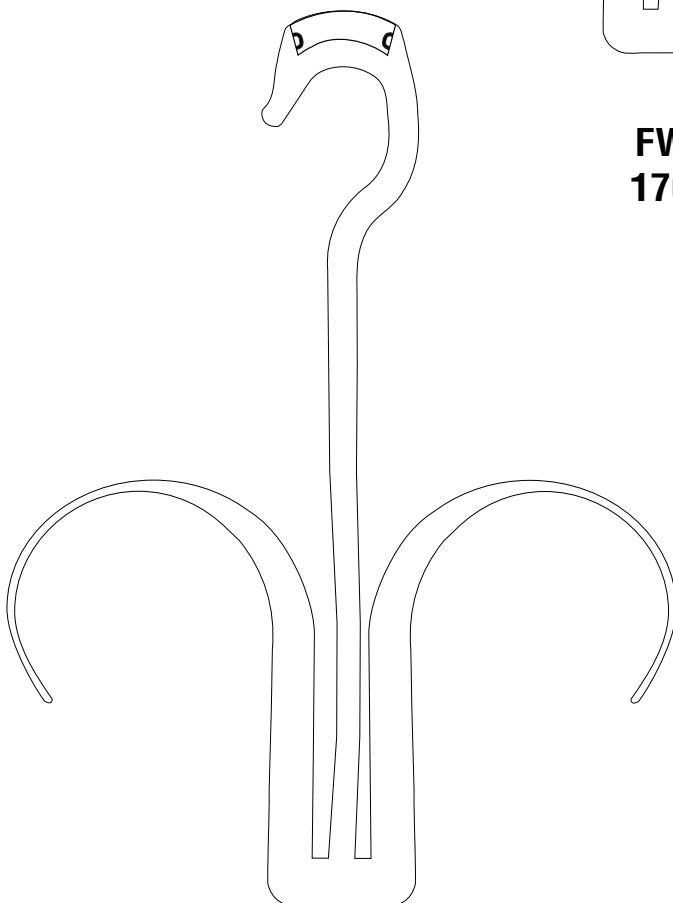

**FW103
215mm**

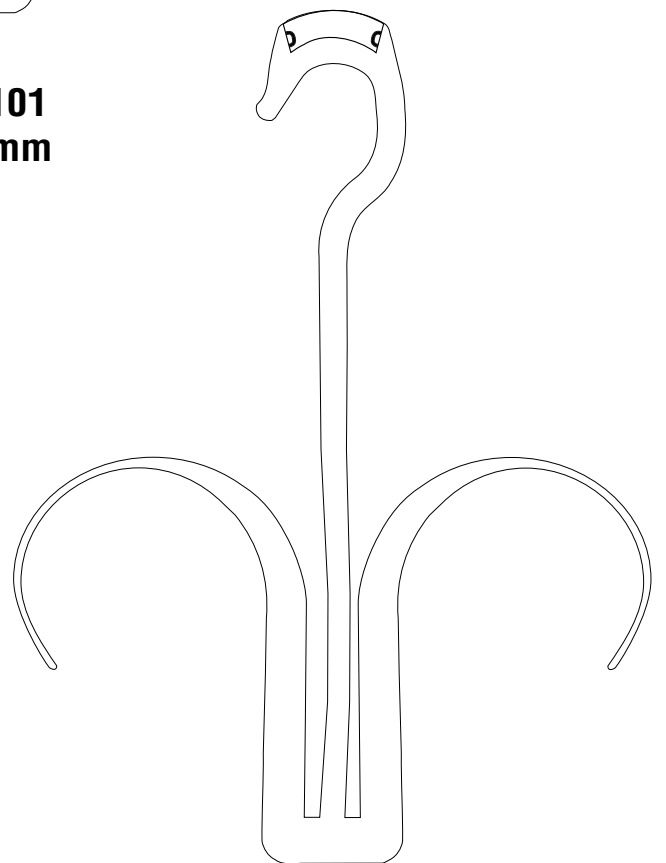

**FW102
195mm**

Category • All

Application • Boots

C O D E

FW78
FW79N

Boot Hanger
180mm

FW78
180mm

***Not available**
in Australia

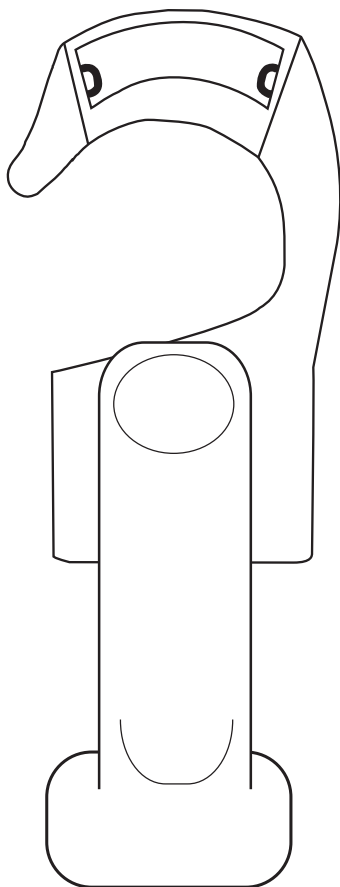

FW79N
130mm

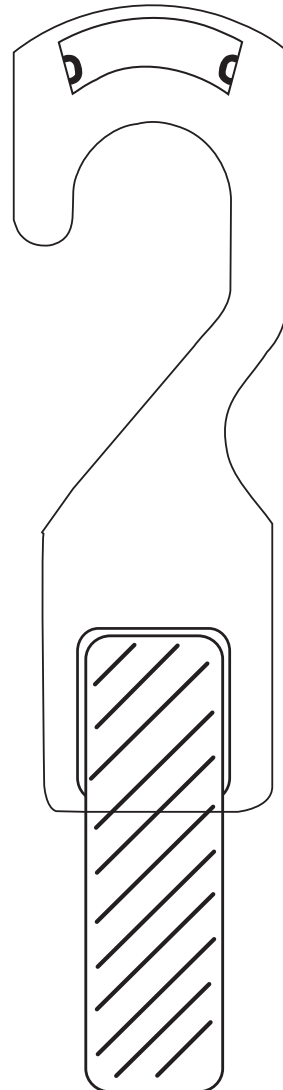

FW78
180mm

***Not available**
in Australia

C O D E

AC21

Category • All

Application • Colour coded size inserts for footwear

Sizing insert
for footwear

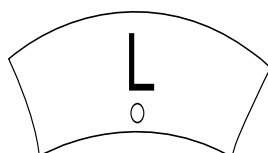

actual size

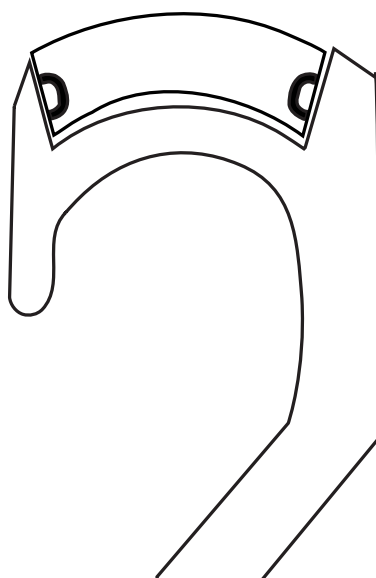

BIG W AC21 SIZE TAB CHART

Footwear Hangers Only

GENERAL		
SIZE	PMS	COLOUR
1	185	Red
2	154	Tan Brown
3	264	Lilac
4	359	Pale Green
5	230	Pink
6	157	Brown
7	444	Grey
8	164	Orange
9	318	Turquoise
10	PB	Proc Blue
11	347	Dark Green
12	279	Dark Blue
13	121	Yellow
1/2	185	Red
2/3	154	Tan Brown
3/4	264	Lilac
4/5	359	Pale Green
5/6	230	Pink
6/7	157	Brown
7/8	444	Grey
8/9	164	Orange
9/10	318	Turquoise
10/11	PB	Proc Blue
11/12	347	Dark Green
12/13	279	Dark Blue
13/1	121	Yellow
XS	318	Turquoise
S	347	Dark Green
M	185	Red
L	PB	Proc Blue
XL	157	Brown

C O D E

SC27

35mm
Scarf
Hanger

Category • All

Application • Scarves, fine fabrics and wraps

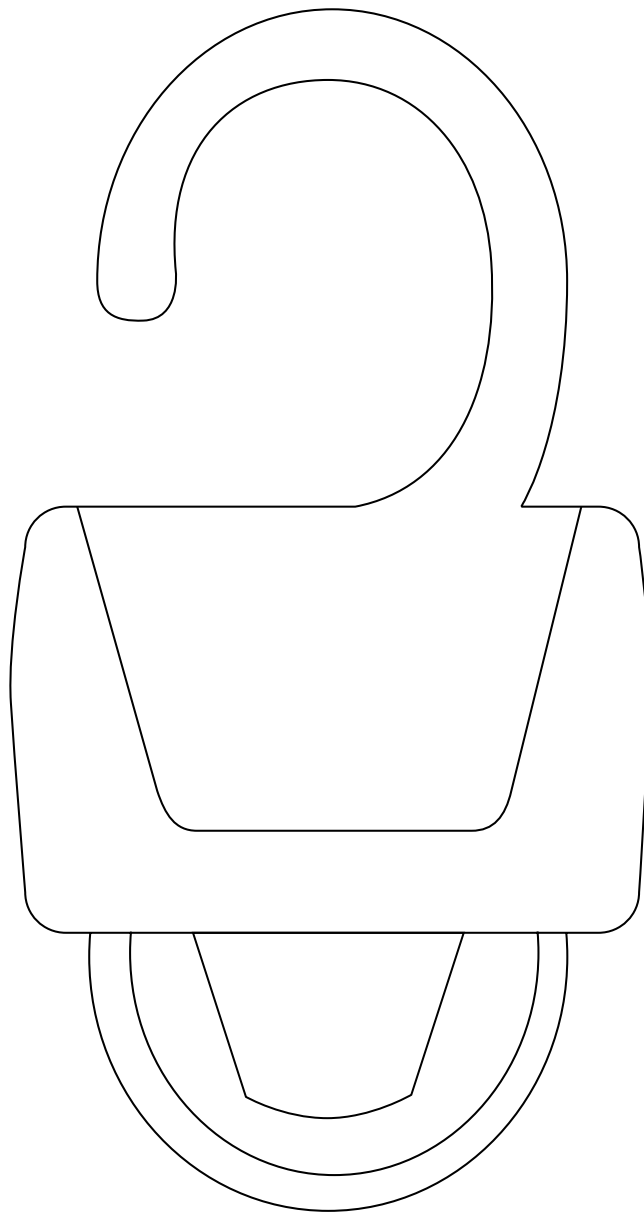

C O D E
SC70

Category • Adult

Application • Shawls, Wraps and Pashminas

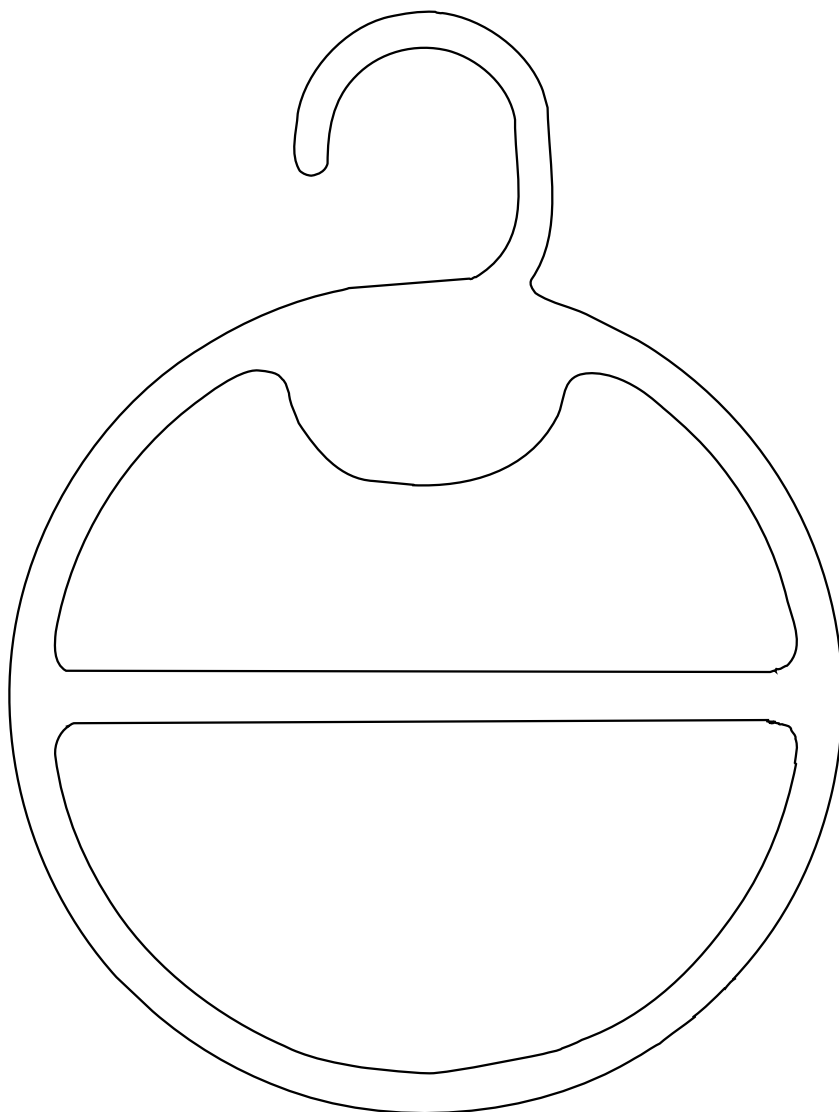

C O D E

SC29

SC71

Shawl Hanger

Category • Adult

Application • Shawls, Wraps and Pashminas

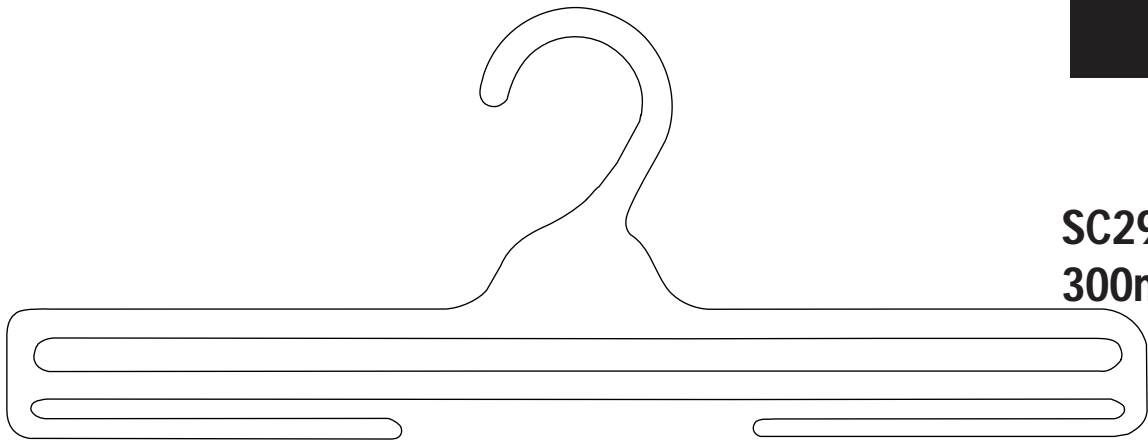

SC29
300mm

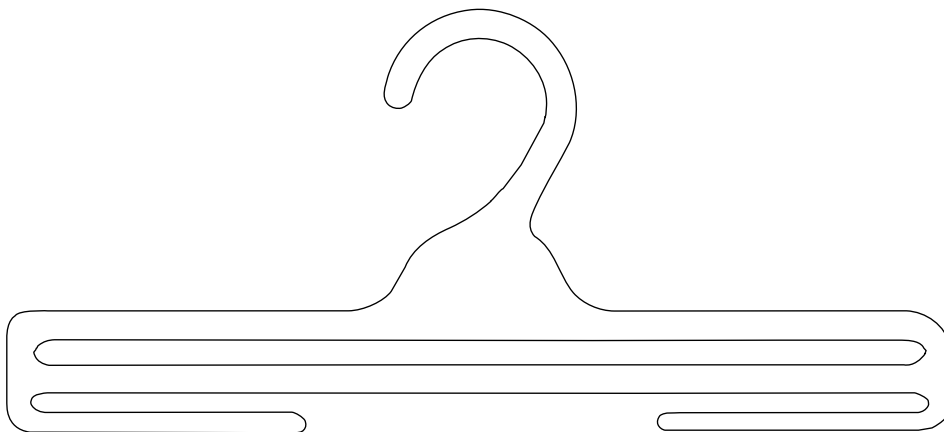

SC71
225mm

C O D E

AC30

Category • Childrens and Adults

Application • Hats, Gloves and Fashion Accessories

**Gun
Hook**

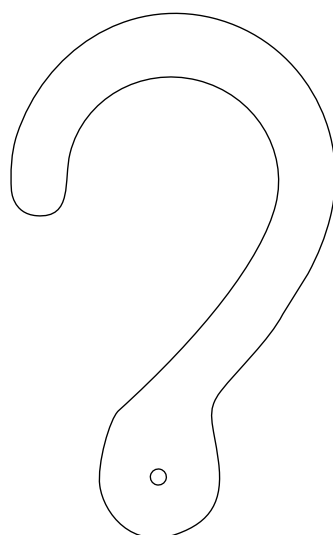

C O D E

SH104

Category • All

Application • Socks

**Sock Hanger
45mm**



C O D E

BA100

Category • All

Application • Belts

**Belt Hanger
150mm**

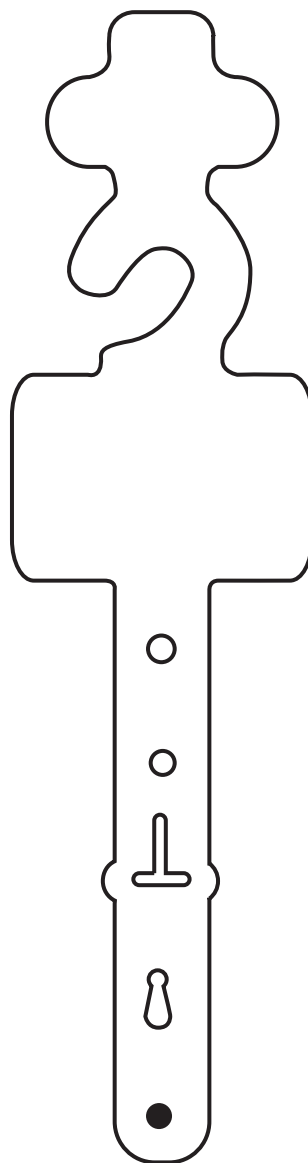

C O D E

WL63

Category • All

Application • Purses, Wallets

**110 mm
Wallet
Hanger**

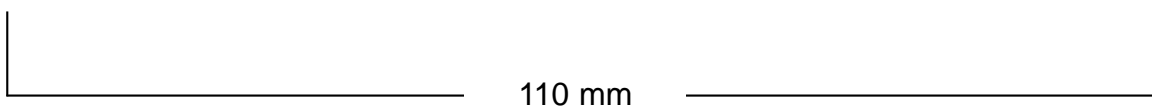
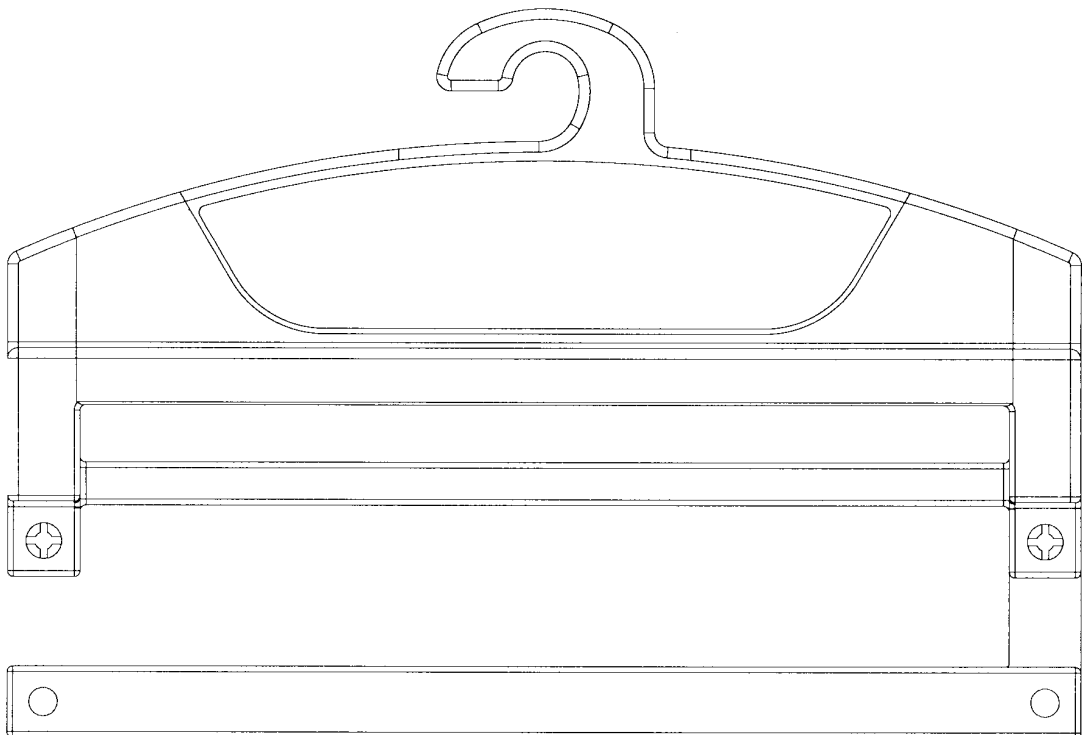

C O D E

AC65

Category • All

Application • Totally interchangeable for all top and bottom hangers

Hook and Loop

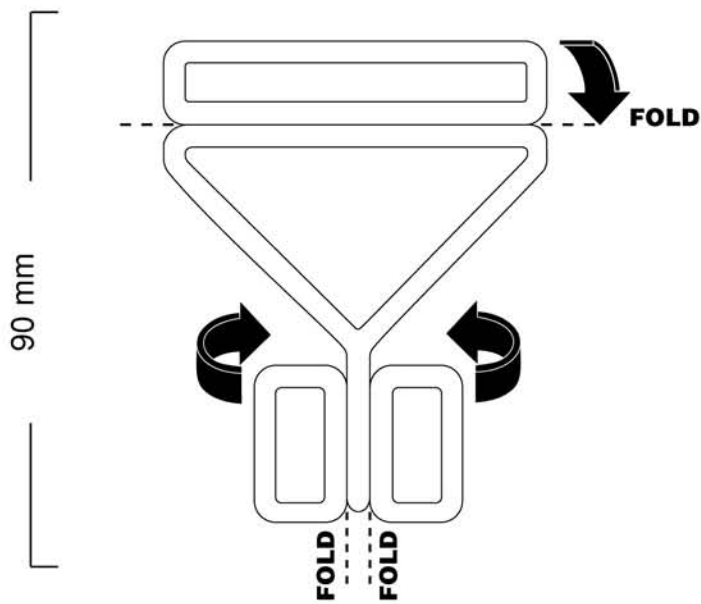

STEP 1

Fold clip at positions indicated

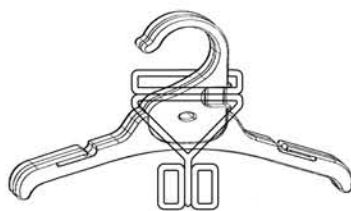

STEP 2

Place clip over tops hanger

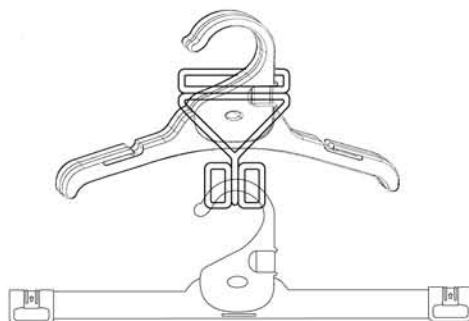

STEP 3

Place bottoms hanger through both sections of lower clip

**AUSTRALIA****MELBOURNE**

214 Blackshaws Road
Altona North, Vic, 3025
Australia.
Ph: 613 9393 3737
Fax: 613 9393 3778

Email: hangers@ticgroup.com.au

SYDNEY

Unit 3, 79 Williamson Road
Ingleburn, 2565, NSW
Australia
Ph: 612 9618 5133
Fax: 612 9618 5733

Email: hangers.syd@ticgroup.com.au

ASIA**HONG KONG**

Unit 3,5,6 and 7, 29/F Saxon Tower,
7 Cheung Shun Street,
Lai Chi Kok, Kowloon Hong Kong.
Ph: 852 2148 3685
Fax: 852 2148 3085

Email: hangers.hk@ticgroupasia.com

NINGBO

No 15 Chuang Ye Da Dao
West District of Free Trade Zone,
Ningbo, China
Ph: 86 574 2687 3733
Fax: 86 574 8682 3880

Email: hangers.cn@ticgroupasia.com



www.ticgroup.com.au

CODE	COLOURS	DESCRIPTION	CATEGORY	AUSTRALIA \$	US \$	BOX QTY'S
TOPS						
TH40X	BLACK	250mm Top Hanger	Infants	0.1160	0.0820	900
TH41X	BLACK	300mm Top Hanger	Childrens	0.1210	0.0860	700
TH42X	BLACK	350mm Top Hanger	Childrens	0.1320	0.0940	670
TH43	BLACK	400mm Top Hanger	Adults	0.1540	0.1090	470
TH45	BLACK	460mm Top Hanger	Adults	0.1760	0.1250	370
TH46	BLACK	520mm Top Hanger	Adults	0.1980	0.1410	260
KN44	BLACK	420mm Knitwear Hanger	Adults	0.2420	0.1720	320
KN47	BLACK	460mm Knitwear Hanger	Adults	0.2640	0.1870	290
SU86	BLACK	460mm Jacket Hanger	Adults	0.7480	0.5310	60
SPECIALTY						
FR78	BLACK	250X320mm Frame Hanger	Childrens	0.2200	0.1560	210
FR79	BLACK	250X350mm Frame Hanger	Childrens	0.2420	0.1720	180
FR80	BLACK	350x430mm Frame Hnager	Childrens	0.2970	0.2110	100
TH 40D	BLACK	250mm Hanger	Childrens Multi Garments	0.2500	0.1800	500
TH 42D	BLACK	350mm Hanger	Childrens Multi Garments	0.2800	0.2010	350
TH 45D	BLACK	460mm Hanger	Menswear Mutli Garments	0.3600	0.2600	150
TP90	BLACK	210mm 2 Prong Hanger	Childrens Multi Garments	0.1000	0.0760	1600
TP91	BLACK	210mm 3 Prong Hanger	Childrens Multi Garments	0.1200	0.0910	1300
BOTTOMS						
BH60	BLACK	210mm Bottom Clip Hanger	Childrens	0.2320	0.1650	450
BH61	BLACK	280mm Bottom Clip Hanger	Childrens	0.2750	0.1950	340
BH62	BLACK	310mm Bottom Clip Hanger	Adults	0.2970	0.2110	340
BH63	BLACK	350mm Bottom Clip Hanger	Adults	0.3190	0.2260	290
BSL82	BLACK	310mm Bottom Soft Lock Peg Hanger	Adults	0.3520	0.2500	340
PH54X	BLACK	190mm Prong Hanger	Childrens	0.1320	0.0940	560
PH55X	BLACK	250mm Prong Hanger	Childrens	0.1770	0.1260	410
BH97	BLACK	320mm Trouser Hanger	Childrens	0.3450	0.2450	300
BH99	BLACK	360mm Trouser Hanger	Adults	0.3850	0.2730	420
LH94	BLACK	180mm Leggings Hanger	Childrens	0.1320	0.0940	900

Lead Times:
AUSTRALIA:- From receipt of order despatch time is 2 business days.
CHINA:- Despatch 3 business days from receipt of all customs documentation.
INDIA:- Despatch 3 business days from receipt of all customs documentation.

Box Qty's: All deliveries are full box/bag quantities.

Payment Terms: Payment prior to delivery (PPD) or 30 days from date of invoice to approved customers.

**MELBOURNE**

214 Blackshaws Road
Altona North, Vic, 3025
Australia.

Ph: 613 9393 3737

Fax: 613 9393 3778

Email: hangers@ticgroup.com.au

AUSTRALIA**SYDNEY**

Unit 3, 79 Williamson Road
Ingleburn, 2565, NSW
Australia

Ph: 612 9618 5133

Fax: 612 9618 5733

Email: hangers.syd@ticgroup.com.au

ASIA**HONG KONG**

Unit 3,5,6 and 7, 29/F Saxon Tower,
7 Cheung Shun Street,
Lai Chi Kok, Kowloon Hong Kong.

Ph: 852 2148 3685

Fax: 852 2148 3085

Email: hangers.hk@ticgroupasia.com

NINGBO

No 15 Chuang Ye Da Dao
West District of Free Trade Zone,
Ningbo, China

Ph: 86 574 2687 3733

Fax: 86 574 8682 3880

Email: hangers.cn@ticgroupasia.com



www.ticgroup.com.au

CODE	COLOURS	DESCRIPTION	CATEGORY	AUSTRALIA \$	US \$	BOX QTY'S
LINGERIE						
BR 32	CRYSTAL	285mm Bra Hanger	Youth & Ladieswear	0.0620	0.0440	1100
LH 34	CRYSTAL	250mm Brief Hanger	Ladieswear	0.0620	0.0440	1200
LH 34	BLACK	250mm Brief Hanger	Menswear	0.0620	0.0440	1200
LH35	BLACK	210mm Brief Hanger	Childrenswear	0.0480	0.0340	1400
FOOTWEAR						
FW 24	BLACK	115mm Thong Hanger	All Groups	0.0720	0.0510	2200
FW 25	BLACK	170 mm Multi Purpose Hanger	All Groups	0.0940	0.0670	600
FW 101	BLACK	170mm Goose Neck Hanger	All Groups	0.0980	0.0700	400
FW 77	BLACK	195mm Multi Purpose Hanger	All Groups	0.0940	0.0670	500
FW 102	BLACK	195mm Multi Purpose Hanger	All Groups	0.1080	0.0770	400
FW 103	BLACK	215mm Multi Purpose Hanger	All Groups	0.1450	0.1030	400
FW 23	BLACK	70mm U End Hanger	Childrens	0.0720	0.0510	2000
FW 75	BLACK	120mm U End Hanger	All Groups	0.0930	0.0660	1200
FW 78	BLACK	180mm Boot Hanger	All Groups	0.1980	0.1410	500
FW 79N	BLACK	130mm Boot Hanger	All Groups	0.1980	0.1410	500
SCARF						
SC 27	BLACK	35mm Small Scarf Hanger	All Groups	0.0550	0.0390	2300
SC 71	BLACK	225mm Small Shawl Hanger	All Groups	0.1270	0.0900	1000
SC 29	BLACK	300mm Shawl Hanger	Adults	0.1320	0.0940	540
SC 70	BLACK	Round Scarf Hanger	All Groups	0.0880	0.0620	500
AC 30	BLACK	Gun Hook	All Groups	0.0330	0.0230	8000
ACCESSORIES						
AC67	BLACK	Foam Sleeves (pair)	Adults	0.1000	0.0710	580
AC65	BLACK	Hook & Loop	Childrens	0.0220	0.0160	100 pkt
BA100	BLACK	Belt Hanger	All Groups	0.1000	0.0710	2000
WL63	BLACK	Wallet Hanger	All Groups	0.1400	0.0980	1000
SH104	BLACK	Sock Hanger	All Groups	0.0280	0.0200	10000
SIZE CLIPS & TABS						
AC 16	ASSTD	Size Clips	All Groups	0.0130	0.0092	200 pkt
AC 18N	ASSTD	Metal Hook Size Clips	Adults	0.0700	0.0500	200
AC 21	ASSTD	Size Tabs - Footwear	All Groups	0.0080	0.0057	1000
AC 22	ASSTD	Size Tabs - Lingerie	All Groups	0.0080	0.0057	1000

Lead Times: **AUSTRALIA:-** From receipt of order despatch time is 2 business days.
CHINA:- Despatch 3 business days from receipt of all customs documentation.
INDIA:- Despatch 3 business days from receipt of all customs documentation.

Box Qty's: All deliveries are full box/bag quantities.

Payment Terms: Payment prior to delivery (PPD) or 30 days from date of invoice to approved customers.